

Community Services Department
Planning and Building
TENTATIVE SUBDIVISION MAP
APPLICATION



Community Services Department
Planning and Building
1001 E. Ninth St., Bldg. A
Reno, NV 89512-2845

Telephone: 775.328.6100

Tentative Subdivision Map

Washoe County Code (WCC) Chapter 110, Article 608, Tentative Subdivision Map, prescribes the rules and procedures for the regulation and approval of tentative subdivision maps. The Planning Commission shall approve, conditionally approve, or deny the tentative parcel map within sixty (60) days of the date that the application is determined to be complete. See WCC 110.608, for further information.

Development Application Submittal Requirements

Applications are accepted on the 15th of each month (if the 15th is a non-work day, the first working day after the 15th)

1. **Fees:** See Master Fee Schedule. **Bring payment with your application to Community Services Department (CSD). Make check payable to Washoe County.** The following fees will also need to be paid:
 - A fee to the Engineering Department for Technical Plan Check.
 - A separate check made payable to the Nevada Division of Environmental Protection (\$100 base fee plus \$1 per lot) is required upon submittal.
 - A separate check made payable to the Nevada Division of Water Resources (\$150 base fee plus \$1 per lot) is required upon submittal.
2. **Development Application:** A completed Washoe County Development Application form.
3. **Owner Affidavit:** The Owner Affidavit must be signed and notarized by all owners of the property subject to the application request.
4. **Proof of Property Tax Payment:** The applicant must provide a written statement from the Washoe County Treasurer's Office indicating all property taxes for the current quarter of the fiscal year on the land have been paid.
5. **Application Materials:** The completed Tentative Subdivision Map Application materials.
6. **Title Report:** A preliminary title report, with an effective date of no more than one hundred twenty (120) days of the submittal date, by a title company which provides the following information:
 - Name and address of property owners.
 - Legal description of property.
 - Description of all easements and/or deed restrictions.
 - Description of all liens against property.
 - Any covenants, conditions and restrictions (CC&Rs) that apply.

Submit Title Report with "Original Packet" only. You may be requested to provide additional copies, but do not include Title Report in other copies of the packet.
7. **Traffic Impact Report:** Traffic impact reports are required whenever the proposed development will create the potential to generate 80 or more weekday peak hour trips as determined using the latest edition of the Institute of Transportation Engineers (ITE) trip generation rates or other such sources as may be accepted by Washoe County Engineering. Projects with less than 200 peak hour trips may not need to perform an impact analysis for future years. Traffic consultants are encouraged to contact Washoe County Engineering staff prior to preparing a traffic impact report.
8. **Development Plan Specifications:**
 - a. Vicinity map showing the proposed development in relation to the surrounding area with distance to primary and secondary access/egress and in relationship to Interstate 80, Highway 395, I-580, or other major arterials.
 - b. Date, north arrow, standard engineering scale (e.g. scale 1" = 100', 1" = 200', or 1" = 500') and index with number of each sheet in relation to the total number of sheets.
 - c. Name of subdivision, applicant, property owner and engineer.

- d. General notes as required.
 - e. Land use data (number of lots, total area, common area, gross density, average lot size, largest and smallest lot at a minimum).
 - f. Engineer's statement with wet stamp including a note by the project engineer or design professional indicating compliance with all applicable provisions of the Washoe County Development Code.
9. **Map Series (the following at a minimum must be shown):**
- a. Lot size with dimensions showing all streets and ingress/egress to the property.
 - b. Property boundary lines, distances and bearings.
 - c. Show the location of all existing buildings that will remain (with distances from the property lines and from each other), all existing buildings that will be removed, and site improvements on a base map with existing and proposed topography expressed in intervals of no more than five (5) feet.
 - d. Show the location and configuration of all existing and proposed wells, septic systems and leach fields, overhead utilities, and water and sewer lines.
 - e. Show locations of parking, landscaping, signage and lighting (if applicable).
 - f. Contours (labeled) at five (5) foot intervals or two (2) foot intervals where, in the opinion of the County Engineer, topography is a major factor in the development.
 - g. Indication of prominent landmarks, areas of unique natural beauty, rock outcroppings, vistas and natural foliage which will be deciding considerations in the design of the development.
 - h. The cross sections of all right-of-ways, streets, alleys or private access ways within the proposed development, proposed name and approximate grade of each, and approximate radius of all curves and diameter of each cul-de-sac. Plans to mitigate visual impacts of all cuts and fills over five (5) feet in height.
 - i. The width and approximate location of all existing or proposed easements, whether public or private, for roads, drainage, sewers, irrigation, or public utility purposes.
 - j. Location and size of any land to be reserved or dedicated for parks, recreation areas, common open space areas, schools, or other public uses.
 - k. If any portion of the land within the boundary of the development is subject to inundation or storm water overflow, as shown on the adopted Federal Emergency Management Agency's Flood Boundary and Floodway Maps, that fact and the land so affected shall be clearly shown on the map by a prominent note on each sheet, as well as width and direction of flow of each water course within the boundaries of the development.
 - l. Existing roads, trails, or rights-of-way within the development shall be designated on the map. Topography and existing developments within three hundred (300) feet must also be shown on the map.
 - m. Location of snow storage areas sufficient to handle snow removed from public and private streets, if applicable.
 - n. All known areas of potential hazard including, but not limited to, earth slide areas, avalanche areas, or otherwise hazardous slopes, shall be clearly designated on the map. Additionally, active fault lines (post-Holocene) shall be delineated on the map together with lines delineating required building setbacks.
 - o. Boundary of any wetland areas and the location of any springs within the project site.
 - p. Emergency access roadway.
 - q. Building envelopes if a hillside development is proposed and areas that may be fenced and type of fencing to be allowed.
 - r. Significant Hydrologic Resources. Indicate the critical and sensitive buffer zones according to Article 418 of the Washoe County Development Code.
 - s. Preliminary landscape plan for all cuts and fill slopes, utility trenches not contained within roadways, entrances, buffer zones and all arterial roadway treatment.

- t. Easements over trail systems, if required.
 - u. Traffic Impact Report (if needed) : Traffic impact reports are required whenever the proposed development project will generate 80 or more weekday peak hour trips as determined using the latest edition of the Institute of Transportation Engineers (ITE) trip generation rates or other such sources as may be accepted by Washoe County Engineering and Capital Projects. Projects with less than 200 peak hour trips may not need to perform an impact analysis for future years. Traffic consultants are encouraged to contact Engineering and Capital Projects staff prior to preparing a traffic impact report.
10. **Grading Plan (in addition to requirements above, if needed):**
- a. Location and limits of all work to be done.
 - b. Existing contours and proposed contours.
 - c. Existing drainage (natural and man-made) and proposed drainage patterns.
 - d. Quantities of excavation, fill, and disturbed surface area shall be calculated and shown on the site plan.
 - e. Quantities of material proposed to be removed from the site must be shown. The proposed disposal area and the disposition of fill must be noted on the site plan.
 - f. Limiting dimensions of cut and fill.
 - g. Proposed BMP's (Best Management Practices) for controlling water and wind erosion if a disturbed area is left undeveloped for over thirty (30) days.
 - h. Walls and terraces with proposed height.
 - i. A minimum of two (2) cross sections of the project site depicting the major grading as proposed and the relationship of the project site to existing development within two hundred (200) feet.
11. **Hillside Ordinance:** Applications on properties containing slopes in excess of fifteen (15) percent or greater on twenty (20) percent or more of the site must submit all requirements of Article 424, Hillside Development. The Site Analysis Map, Developable Area Map, Constraint and Mitigation Analysis, and Detailed Contour Analysis are required. Building envelopes, disturbed areas, and areas to remain undisturbed for each created lot shall be shown on the tentative and final map.
12. **Street Names:** A completed "Request to Reserve New Street Name" form (included in application packet). Please print all street names on the tentative map. Note whether they are existing or proposed.
13. **Washoe County Assessor's Office Map:** A site map (labeled Assessor's Site Map) utilizing the Assessor's parcel page(s) as a base, must be submitted showing the development to scale. (The Assessor's pages may be combined and the scale utilized by the Assessor may be altered to show the development in the most graphic method. If so, please note the scale and label accordingly on the submitted site plan.)
14. **Washoe County Health District:** An "Acknowledgment of Water Service" letter from the water purveyor shall be submitted with the tentative subdivision map application. Washoe County Health District will consider the application incomplete without compliance with NAC 445A.666.
15. **Packets:** Six (6) packets and flash drive or DVD - any digital documents need to have a resolution of 300 dpi. One (1) packet must be labeled "Original" and contain a signed and notarized Owner Affidavit. Each packet shall include one (1) 8.5" x 11" reduction of any applicable site plan, development plan, and/or application map. These materials must be readable. Labeling on these reproductions should be no smaller than 8 point on the 8½ x 11" display. Large format sheets should be included in a slide pocket(s). Any specialized reports identified above shall be included as attachments or appendices and be annotated as such. **Applicants are encouraged to mail an application packet to the Citizen Advisory Board members prior to their CAB meeting review.**
16. **Special Packets:** In addition to the six (6) packets, the following information in the number specified shall be included with the project submittal:
- a. **Geotechnical Report:** Six (6) copies of a preliminary geotechnical report prepared by a Nevada registered civil engineer, including soils characteristics sufficient for use in tentative structural design (i.e. street sections, building pads, etc.) and potential geologic hazards.

- b. **Preliminary Grading, Drainage and Erosion Control Plan:** Six (6) copies of a preliminary grading, drainage, and erosion control plan for the entire project, prepared by a Nevada registered civil engineer, showing existing contours at maximum five (5) foot intervals, approximate street grades, proposed surface drainage, approximate extent of cut and fill slopes, approximate building envelopes and all pad elevations sufficient to convey the impact of grading.
- c. **Hydrological Report:** Six (6) copies of a hydrological report including such conditions as ground water or seepage conditions, and location of wells and springs, to be prepared by a qualified civil engineer registered with the State of Nevada.
- d. **Tree Preservation and Protection Plan:** Six (6) copies of a tree preservation and protection plan, where applicable, shall be made a part of the tentative plat with indication thereon of those trees proposed to be removed, those to remain, and where new trees are to be planted.
- e. **Preliminary Landscape Plan:** If the subject property is adjacent to an arterial roadway, submit four (4) copies of a preliminary landscape plan for the area along the roadway. The plans shall comply with the provisions of Article 412 of the Development Code.

Notes:

- (i) Application and map submittals must comply with all specific criteria as established in the Washoe County Development Code and/or the Nevada Revised Statutes.
- (ii) Appropriate map engineering and building architectural scales are subject to the approval of Planning and Building and/or Engineering and Capital Projects.
- (iii) All oversized maps and plans must be folded to a 9" x 12" size.
- (iv) Based on the specific nature of the development request, Washoe County reserves the right to specify additional submittal packets, additional information and/or specialized studies to clarify the potential impacts and potential conditions of development to minimize or mitigate impacts resulting from the project. **No application shall be processed until the information necessary to review and evaluate the proposed project is deemed complete by the Director of Planning and Building.**
- (v) **Labels:** If there is a mobile home park within five hundred (500) feet of the proposed project, the applicant is required to submit three (3) sets of mailing labels for every tenant residing in the mobile home park.

Washoe County Development Application

Your entire application is a public record. If you have a concern about releasing personal information, please contact Planning and Building staff at 775.328.6100.

| | | | |
|---|-----------------------------|---------------------------------------|-----------------|
| Project Information | | Staff Assigned Case No.: _____ | |
| Project Name: Luxelocker Spanish Springs | | | |
| Project Description: Merging three parcels into one, and further subdividing into additional parcels, creating parcels which will become future storage units. | | | |
| Project Address: 11455 Digital Ct, Sparks, NV 89441 | | | |
| Project Area (acres or square feet): 159,238 sqft or 3.66 Acres | | | |
| Project Location (with point of reference to major cross streets AND area locator): Ingenuity Ave. & Digital Ct., next to Pyramid HW. | | | |
| Assessor's Parcel No.(s): | Parcel Acreage: | Assessor's Parcel No.(s): | Parcel Acreage: |
| 530-491- 08 | 1.26 3.66 | 530-491-10 | 1.20 |
| 530-491-09 | 1.20 | | |
| Indicate any previous Washoe County approvals associated with this application: Case No.(s). 4904477 | | | |
| Applicant Information (attach additional sheets if necessary) | | | |
| Property Owner: | | Professional Consultant: | |
| Name: SPANISH SPRINGS STORAGE PARTNERS LLC | | Name: US Geomatics | |
| Address: 1845 McCulloch Blvd., Ste A6 | | Address: P.O. BOX 3299 | |
| Lake Havasu City, AZ | Zip: 86403 | Reno, Nevada | Zip: 89505 |
| Phone: 928-854-7747 | Fax: | Phone: (775)786-5111 | Fax: |
| Email: mychal@desertlandgroup.com | | Email: info@usgeomatics.com | |
| Cell: 928-230-9876 | Other: | Cell: | Other: |
| Contact Person: Mychal Gorden | | Contact Person: Glen C. Armstrong | |
| Applicant/Developer: | | Other Persons to be Contacted: | |
| Name: Luxelocker, LLC | | Name: Glen C. Armstrong | |
| Address: 1845 McCulloch Blvd., Ste A6 | | Address: 648 Lander Street | |
| Lake Havasu City, AZ | Zip: 86403 | Reno, Nevada | Zip: 89509 |
| Phone: 928-854-7747 | Fax: | Phone: (775)786-5111 | Fax: |
| Email: muchal@desertlandgroup.com | | Email: garmstrong@usgeomatics.com | |
| Cell: 928-230-9876 | Other: | Cell: (775)560-8516 | Other: |
| Contact Person: Mychal Gorden | | Contact Person: Glen C. Armstrong | |
| For Office Use Only | | | |
| Date Received: | Initial: | Planning Area: | |
| County Commission District: | | Master Plan Designation(s): | |
| CAB(s): | | Regulatory Zoning(s): | |

Tentative Subdivision Map Application Supplemental Information

(All required information may be separately attached)

1. What is the location (address or distance and direction from nearest intersection)?

11455 Digital Ct, Sparks NV 89411, located on intersection of Digital Ct. & Ingenuity Ave.

2. What is the subdivision name (proposed name must not duplicate the name of any existing subdivision)?

Luxelocker Spanish Springs

3. Density and lot design:

| | |
|--|------------------------------|
| a. Acreage of project site | 3.66 ac. |
| b. Total number of lots | 98 Lots |
| c. Dwelling units per acre | 26.77 Units / Acre |
| d. Minimum and maximum area of proposed lots | Max=766.5 sf Min=504.0 sf |
| e. Minimum width of proposed lots | 14.00 Feet |
| f. Average lot size | 615 sf |

4. What utility company or organization will provide services to the development:

| | |
|---------------------------------|---|
| a. Sewer Service | Washoe County |
| b. Electrical Service | NV Energy |
| c. Telephone Service | Charter Communication |
| d. LPG or Natural Gas Service | NV Energy |
| e. Solid Waste Disposal Service | Waste Management |
| f. Cable Television Service | Charter |
| g. Water Service | Domestic by TMWA and Irrigation by City of Sparks |

5. For common open space subdivisions (Article 408), please answer the following:

- a. Acreage of common open space:

2.24 ac

- b. What development constraints are within the development and how many acres are designated slope, wetlands, faults, springs, and/or ridgelines:

The only development constraints for this project is the building setbacks.

- c. Range of lot sizes (include minimum and maximum lot size):

766.5 sf (max) - 504.0 sf (min)

d. Proposed yard setbacks if different from standard:

Standard Setbacks

e. Justification for setback reduction or increase, if requested:

N/A

f. Identify all proposed non-residential uses:

S-1 Storage, B Business

g. Improvements proposed for the common open space:

Landscaping and pavement for access to units

h. Describe or show on the tentative map any public or private trail systems within common open space of the development:

N/A

i. Describe the connectivity of the proposed trail system with existing trails or open space adjacent to or near the property:

N/A

j. If there are ridgelines on the property, how are they protected from development?

N/A

k. Will fencing be allowed on lot lines or restricted? If so, how?

No Restrictions

l. Identify the party responsible for maintenance of the common open space:

Spanish Springs Storage Partners, LLC

6. Is the project adjacent to public lands or impacted by "Presumed Public Roads" as shown on the adopted April 27, 1999 Presumed Public Roads (see Washoe County Engineering website at <http://www.washoecounty.us/pubworks/engineering.htm>). If so, how is access to those features provided?

No

7. Is the parcel within the Truckee Meadows Service Area?

Yes No

8. Is the parcel within the Cooperative Planning Area as defined by the Regional Plan?

Yes No If yes, within what city?

9. Has an archeological survey been reviewed and approved by SHPO on the property? If yes, what were the findings?

No

10. Indicate the type and quantity of water rights the application has or proposes to have available:

| | | | |
|--------------------|--|--------------------|--|
| a. Permit # | | acre-feet per year | |
| b. Certificate # | | acre-feet per year | |
| c. Surface Claim # | | acre-feet per year | |
| d. Other # | | acre-feet per year | |

a. Title of those rights (as filed with the State Engineer in the Division of Water Resources of the Department of Conservation and Natural Resources):

11. Describe the aspects of the tentative subdivision that contribute to energy conservation:

proposing to using landscaping that is native to the area to limit the use of irrigation and using LED light fixtures to limit electrical consumption.

12. Is the subject property in an area identified by Planning and Building as potentially containing rare or endangered plants and/or animals, critical breeding habitat, migration routes or winter range? If so, please list the species and describe what mitigation measures will be taken to prevent adverse impacts to the species:

No

13. If private roads are proposed, will the community be gated? If so, is a public trail system easement provided through the subdivision?

Drives to access the storage units and yes the community will be gated and the public trail system is the sidewalk along the streets surrounding the property.

14. Are there any applicable policies of the adopted area plan in which the project is located that require compliance? If so, which policies and how does the project comply?

N/A

15. Are there any applicable area plan modifiers in the Development Code in which the project is located that require compliance? If so, which modifiers and how does the project comply?

N/A

16. Will the project be completed in one phase or is phasing planned? If so, please provide that phasing plan:

the project will be completed in one phase

17. Is the project subject to Article 424, Hillside Development? If yes, please address all requirements of the Hillside Ordinance in a separate set of attachments and maps.

| | | |
|------------------------------|--|---|
| <input type="checkbox"/> Yes | <input checked="" type="checkbox"/> No | If yes, include a separate set of attachments and maps. |
|------------------------------|--|---|

18. Is the project subject to Article 418, Significant Hydrologic Resources? If yes, please address Special Review Considerations within Section 110.418.30 in a separate attachment.

| | | |
|------------------------------|--|---------------------------------------|
| <input type="checkbox"/> Yes | <input checked="" type="checkbox"/> No | If yes, include separate attachments. |
|------------------------------|--|---------------------------------------|

Grading

Please complete the following additional questions if the project anticipates grading that involves: (1) Disturbed area exceeding twenty-five thousand (25,000) square feet not covered by streets, buildings and landscaping; (2) More than one thousand (1,000) cubic yards of earth to be imported and placed as fill in a special flood hazard area; (3) More than five thousand (5,000) cubic yards of earth to be imported and placed as fill; (4) More than one thousand (1,000) cubic yards to be excavated, whether or not the earth will be exported from the property; or (5) If a permanent earthen structure will be established over four and one-half (4.5) feet high:

19. How many cubic yards of material are you proposing to excavate on site?

2,939 yd³

20. How many cubic yards of material are you exporting or importing? If exporting of material is anticipated, where will the material be sent? If the disposal site is within unincorporated Washoe County, what measures will be taken for erosion control and revegetation at the site? If none, how are you balancing the work on-site?

2,107 yd³. Disposal of the 2,107 yd³ of export will stay within the SUP approved mass grading of the SSCP area.

21. Can the disturbed area be seen from off-site? If yes, from which directions, and which properties or roadways? What measures will be taken to mitigate their impacts?

No, because once the project is completed the disturbed areas will be hidden from view by the proposed buildings and cmu perimeter wall

22. What is the slope (Horizontal/Vertical) of the cut and fill areas proposed to be? What methods will be used to prevent erosion until the revegetation is established?

The slope of the proposed cut / fill areas will not exceed 3:1 and will not require re-vegetation.

23. Are you planning any berms and, if so, how tall is the berm at its highest? How will it be stabilized and/or revegetated?

No berms are planned at this time.

24. Are retaining walls going to be required? If so, how high will the walls be, will there be multiple walls with intervening terracing, and what is the wall construction (i.e. rockery, concrete, timber, manufactured block)? How will the visual impacts be mitigated?

There will be no retaining walls required for this site.

25. Will the grading proposed require removal of any trees? If so, what species, how many, and of what size?

There is no removal of existing trees required.

26. What type of revegetation seed mix are you planning to use and how many pounds per acre do you intend to broadcast? Will you use mulch and, if so, what type?

There will be no revegetation required, as none of the cut / fill slopes require it for slope stabilization.

27. How are you providing temporary irrigation to the disturbed area?

Temporary irrigation to the site is provided by the proposed irrigation service on the south end of the project.

28. Have you reviewed the revegetation plan with the Washoe Storey Conservation District? If yes, have you incorporated their suggestions?

No re-vegetation plan is required at this time.

Tahoe Basin

Please complete the following questions if the project is within the Tahoe Basin:

29. Who is the Tahoe Regional Planning Agency (TRPA) project planner and what is his/her TRPA extension?

| |
|--|
| |
|--|

30. Is the project within a Community Plan (CP) area?

| | | |
|------------------------------|-----------------------------|-------------------|
| <input type="checkbox"/> Yes | <input type="checkbox"/> No | If yes, which CP? |
|------------------------------|-----------------------------|-------------------|

31. State how you are addressing the goals and policies of the Community Plan for each of the following sections:

- a. Land Use:

| |
|--|
| |
|--|

- b. Transportation:

| |
|--|
| |
|--|

- c. Conservation:

| |
|--|
| |
|--|

- d. Recreation:

| |
|--|
| |
|--|

- e. Public Services:

| |
|--|
| |
|--|

32. Identify where the development rights for the proposed project will come from:

| |
|--|
| |
|--|

33. Will this project remove or replace existing housing?

| | | |
|------------------------------|-----------------------------|-------------------------|
| <input type="checkbox"/> Yes | <input type="checkbox"/> No | If yes, how many units? |
|------------------------------|-----------------------------|-------------------------|

34. How many residential allocations will the developer request from Washoe County?

| |
|--|
| |
|--|

35. Describe how the landscape plans conform to the Incline Village General Improvement District landscaping requirements:

| |
|--|
| |
|--|

Request to Reserve New Street Name(s)

The Applicant is responsible for all sign costs.

Applicant Information

Name: _____

Address: _____

Phone : _____

Fax: _____

Private Citizen

Agency/Organization

Street Name Requests

(No more than 14 letters or 15 if there is an "i" in the name. Attach extra sheet if necessary.)

| | |
|--|--|
| | |
| | |
| | |
| | |
| | |
| | |
| | |
| | |
| | |
| | |

If final recordation has not occurred within one (1) year, it is necessary to submit a written request for extension to the coordinator prior to the expiration date of the original

Location

Project Name: _____

Reno

Sparks

Washoe County

Parcel Numbers: _____

Subdivision

Parcelization

Private Street

Please attach maps, petitions and supplementary information.

Approved: _____ Date: _____

Regional Street Naming Coordinator

Except where noted

Denied: _____ Date: _____

Regional Street Naming Coordinator

Washoe County Geographic Information Services

1001 E. Ninth Street
Reno, NV 89512-2845

Phone: (775) 328-2325 - Fax: (775) 328-6133

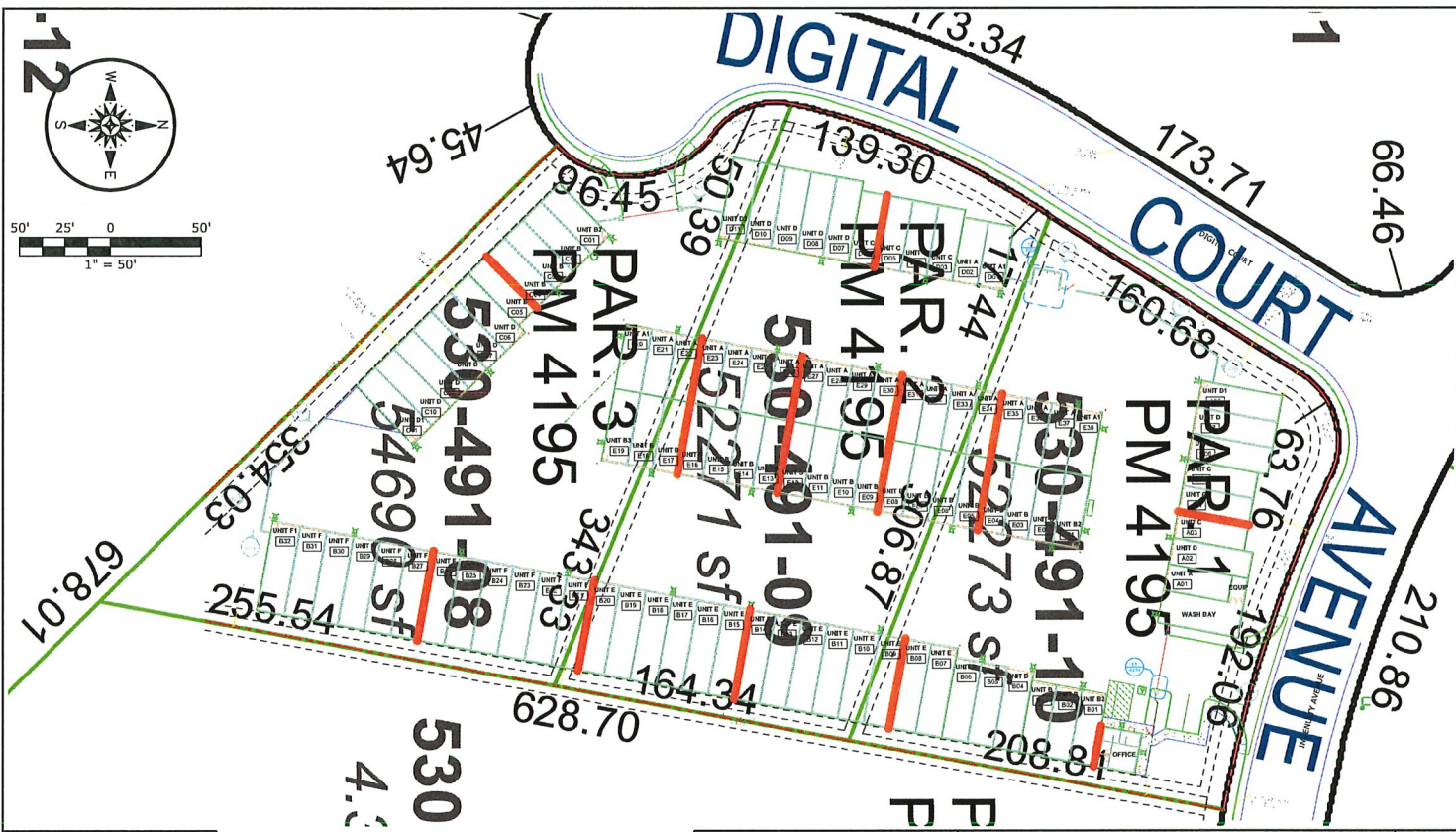

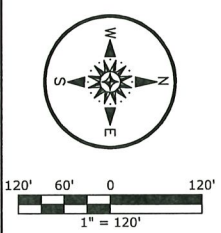
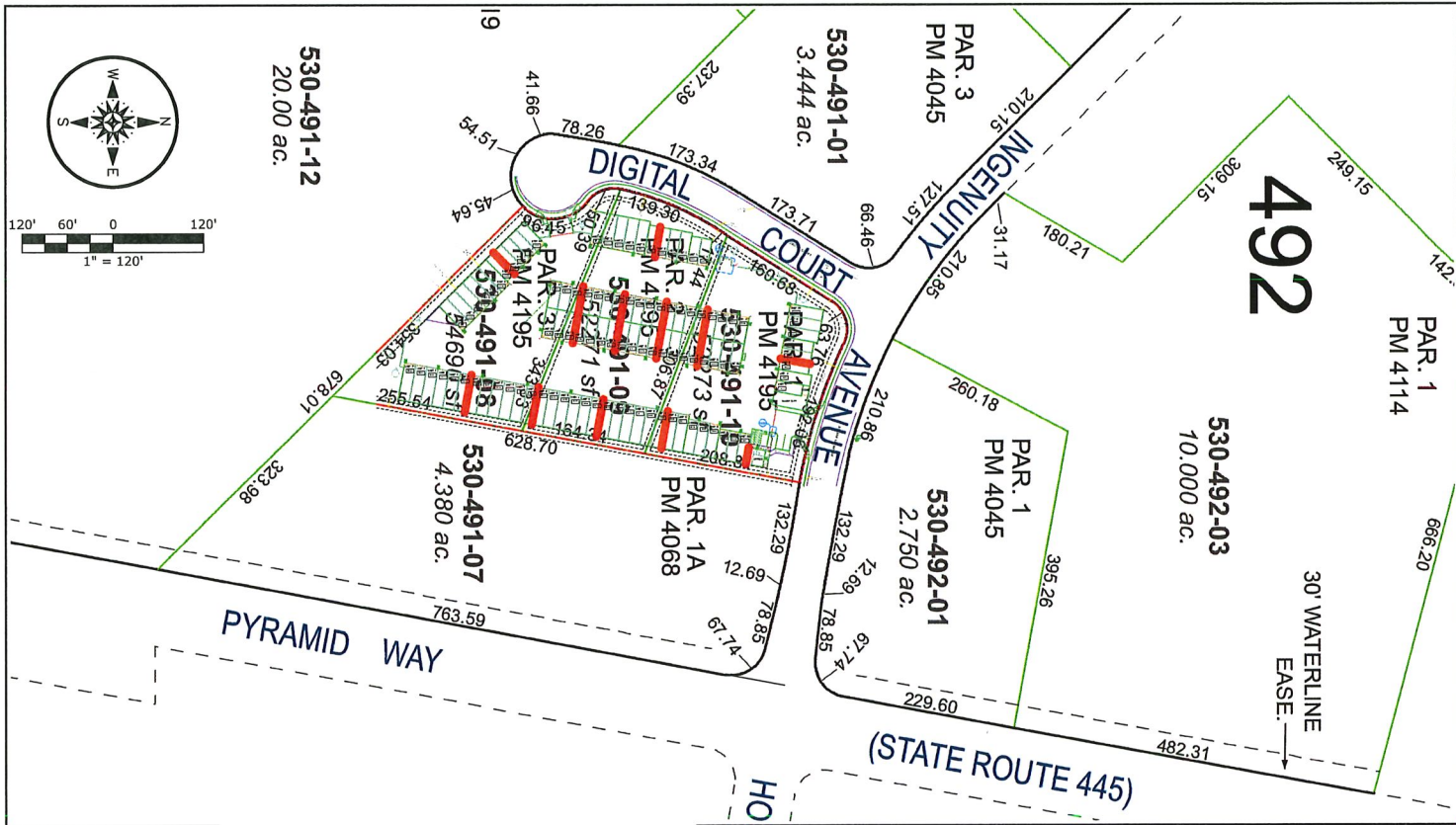

US GEOMATICS
 P.O. Box 3299
 648 Lander Street
 Reno, NV 89505
 P. 775.786.5111
 www.usgeomatix.com
 info@usgeomatix.com

| | | | |
|--------------|------------|-----------------|-----------|
| Project No: | 184-03-19 | Horiz. scale: | 1" = 120' |
| Date: | 10-15-2014 | Vertical scale: | |
| Drawn by: | DJL | Project: | |
| Designed by: | DJL | Horiz. datum: | NAD83 |
| Checked by: | AV | Vertical datum: | NAVD83 |

FOR TENTATIVE TRACT MAP APPLICATION
 SITE PLAN FOR LUXE LOCKER - VICINITY VIEW
**SITUATED IN THE NORTHEAST 1/4 OF SECTION 23
 TOWNSHIP 21 NORTH, RANGE 20 EAST, M.D.M.**
 RENO WASHOE COUNTY NEVADA

SHEET
 1
 OF
 1

PLANT LIST

| KEY NO. | BOTANICAL NAME | COMMON NAME | SIZE | REMARKS |
|------------------------|----------------------|-----------------------|-------------------------|---------------------|
| DECIDUOUS TREES | | | | |
| DR | Q. LAEVOGARRULA | BUR OAK | 24" BOK OR D x 8" B | 2" PIN CAL. HATCHED |
| AG | A. ACER GINALE PLATE | AMERICAN LIME | 1 1/2" PIN CAL. HATCHED | |
| EVERGREEN TREES | | | | |
| PH | P. PARVIFLORA | ADONIS PINE | 8" GAL. OR B x 8" B | 4" PIN HEIGHT |
| PS | P. PARVIFLORA | COLORADO BLUE SPRUCE | 8" GAL. OR B x 8" B | 4" PIN HEIGHT |
| JU | J. UNIDENTIFIED | ARIZONA CYPRINUS | 8" GAL. OR B x 8" B | 4" PIN HEIGHT |
| SHRUBS | | | | |
| 1 | 1. UNIDENTIFIED | SAWD CHERRY | 8" GAL. | 24" PIN HEIGHT |
| A | A. UNIDENTIFIED | SCOTLAND SPAC | 8" GAL. | 24" PIN SPREAD |
| C | C. UNIDENTIFIED | MOONLIGHT BURNING | 8" GAL. | 18" PIN SPREAD |
| F | F. UNIDENTIFIED | DEL PISO PINE | 8" GAL. | 18" PIN SPREAD |
| R | R. UNIDENTIFIED | PODESTILLA | 8" GAL. | 18" PIN SPREAD |
| T | T. UNIDENTIFIED | BULB HEAD | 1 GAL. | 12" PIN HEIGHT |
| CG | CG. UNIDENTIFIED | SPICE TREE | 8" GAL. | 24" PIN HEIGHT |
| E | E. UNIDENTIFIED | TANTARANI HONEYBUCKLE | 8" GAL. | 24" PIN HEIGHT |
| FERNS | | | | |
| D | D. UNIDENTIFIED | YARROW | 1 GAL. | 12" PIN HEIGHT |
| H | H. UNIDENTIFIED | CALIF. FUCHSIA | 1 GAL. | 12" PIN HEIGHT |
| G | G. UNIDENTIFIED | MAUI A. BURNER | 1 GAL. | 12" PIN HEIGHT |
| V | V. UNIDENTIFIED | REISHAN BAGE | 1 GAL. | 12" PIN HEIGHT |
| GRASSES | | | | |
| S | S. UNIDENTIFIED | FLAIDEN GRASS | 1 GAL. | 12" PIN HEIGHT |
| D | D. UNIDENTIFIED | FEATHERGRASS | 1 GAL. | 12" PIN HEIGHT |

LANDSCAPE LEGEND

- ROCK MULCH**
ALL PLANTERS NOT DESIGNATED FOR ROCK MULCH SHALL BE COVERED TO 2" MIN. DEPTH OF 1/2" FRACTURED PLATE COVER HATCHED PERMANENTLY. SPEC. PLACE SANDWICH MULCH MULCH IN ALL PLANT BASKETS. REFER TO DETAIL SHEET L-13.
- DECOMPOSED GRANITE**
ALL PLANTERS AS SHOWN.
2" MIN. DEPTH OF DECOMPOSED GRANITE.
PLACE OVER SANDWICH MULCH MULCH FOR 1/2" MIN. SPEC. PLACE SANDWICH MULCH MULCH IN ALL PLANT BASKETS. REFER TO DETAIL SHEET L-13.
- 2" DIA. SOLID PINE FRACTURED ROCK**
MATCH BROWN COLOR WITH MULCH. REFER TO DETAIL SHEET L-13.

NOTE

IF TREE OR LARGER PROVIDE WIRE CABLE OUTSIDE OF TREE TRUNK. USE 1/2" GALVANIZED CABLE WITH TURN BUCKLES FOR TIGHTENING. USE CLIPS TO SECURE STRAPS PER 1/2" OF 1/2" INCH SPACING AT 4" INTERVALS. PREVENT TREE WITH STRAPS OR LOGS AS SHOWN.

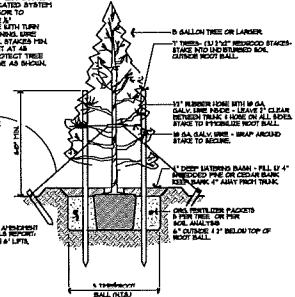

EVERGREEN TREE PLANTING
NOT TO SCALE

GENERAL LANDSCAPE NOTES:

THE CONTRACTOR SHALL COORDINATE ALL WORK WITH OTHER TRADES (ELECTRICAL, PLUMBING, MECHANICAL, ETC.)
ALL SOIL SHALL BE LOOSE TO A DEPTH OF 6" IN ALL PLANTER AREAS PRIOR TO PLANTING. BARE CUT ALL ROCK AND DEBRIS DEEPER THAN 1/2" DIAMETER.
ALL GRASSES SHALL BE APPROVED BY THE OWNER'S REPRESENTATIVE. AFTER SOIL LOGGING, IRRIGATION TUBES AND FUEL GRASSES IS COMPLETE PRIOR TO PLANTING.
SOIL IN THE PLANT BASKETS SHALL BE AMENDED PER A SOIL ANALYSIS REPORT AND RECOMMENDATIONS PREPARED BY AN AGRICULTURAL, METEOROLOGICAL, SOIL SCIENTIST. THE LANDSCAPE CONTRACTOR SHALL TAKE A 1/2" OR 2" SAMPLES A MIN. OF 100 FROM EACH PLANTER AREA AFTER ALL SITE GRADING HAS OCCURRED AND PLANTERS ARE BROUGHT TO GRADE. IF REQUIRED PER CIVIL ENGINEER THE CONTRACTOR SHALL SUBMIT ONE COPIED SAMPLE OF THE SOIL FOR ANALYSIS AND RECOMMENDATIONS. A COPY OF THE SOIL ANALYSIS SHALL BE SUBMITTED TO THE OWNER'S REPRESENTATIVE FOR HIS REVIEW PRIOR TO THE PLANTING. THE CONTRACTOR SHALL AMEND THE FOLLOWING: A CITY OF LENOIR PERMITS AND A LOG OF SOIL LOGGING AND RECOMMENDATIONS INTO THE PLANTING EXCAVATION SOIL. FIELD SOIL AMENDMENT SHALL PER SOIL ANALYSIS REPORT AND RECOMMENDATIONS PRIOR TO BACKFILL OF PLANT WITH SOIL AMENDMENT MAY BE USED FOR INDIVIDUAL SOIL EDUCATION.
THE CONTRACTOR IS RESPONSIBLE FOR PROVIDING PLANT MATERIAL PER ATTACHED AND SPECIFIED QUANTITIES ON THE PLAN. ANY SOIL PROVIDED OVER QUANTITIES LISTED IN THE PLAN LEGEND.

IT IS THE RESPONSIBILITY OF THE CONTRACTOR TO LOCATE AND PROVIDE PLANT MATERIAL AS SPECIFIED ON THIS PLAN. THE CONTRACTOR MAY HAVE A NECESSITY TO PROVIDE SUBSTITUTIONS FOR THE SPECIFIED PLANT MATERIAL UNDER THE FOLLOWING CONDITIONS:
A. ANY SUBSTITUTION PROPOSED SHALL BE SUBMITTED TO THE OWNER'S REPRESENTATIVE WITH TWO SETS OF THE ORIGINAL CONTRACT. SUBSTITUTIONS MUST BE EVALUATED DURING AND FUNCTIONAL GOALS OF THE ORIGINAL PLANT MATERIAL AS DETERMINED BY THE OWNER'S REPRESENTATIVE. ANY CHANGES MUST HAVE THE APPROVAL OF THE OWNER'S REPRESENTATIVE.
B. IF THE NECESSITY THAT BE ACCOMPANIED BY AT LEAST THREE NOTICES FROM PLANT SUPPLIER THAT THE PLANT MATERIAL SPECIFIED IS NOT AVAILABLE PRIOR TO THE CONSTRUCTION PHASE.
C. ALL PLANTS NOT PERMITTED OR EXCEEDING REQUIREMENTS AND RECOMMENDATIONS OF JUNE 2001 (PERMANENT) STANDARD FOR PLANTING SHALL BE REJECTED. THE CONTRACTOR SHALL REMOVE SUCH PLANTS AND REPLACE WITH PLANT MATERIAL IN THE OWNER'S REPRESENTATIVE PRIOR TO PLANTING. FAILURE TO REMOVE PLANT MATERIAL AT HIS EXPENSE, THE OWNER RESERVES THE RIGHT TO REMOVE AND EVALUATE PLANT MATERIAL THROUGHOUT THE CONSTRUCTION AND MAINTENANCE PERIOD.
D. ALL PLANT SUBSTITUTIONS SHALL BE REVIEWED AND ACTION TAKEN BY THE LANDSCAPE ARCHITECT. ALL PLANT MATERIAL SHALL BE APPROVED BY THE OWNER'S REPRESENTATIVE PRIOR TO PLANTING. THE CONTRACTOR SHALL NOTIFY THE OWNER FOR PLANT REVIEW AND APPROVAL. ALL PLANTS NOT APPROVED BY THE OWNER SHALL BE REMOVED IMMEDIATELY FROM THE SITE. THE OWNER

REPRESENTATIVE MAY AT ANY TIME UNTIL FINAL ACCEPTANCE DIRECT THE CONTRACTOR TO REMOVE UNACCEPTABLE MATERIAL. UNLESS COST TO THE OWNER.
THE CONTRACTOR SHALL GUARANTEE ALL PLANT MATERIALS FOR ONE FULL YEAR UPON FINAL ACCEPTANCE OF THE PROJECT. THE CONTRACTOR SHALL MAINTAIN THE SITE INCLUDING BATTER SCREEDING FOR THE ONE YEAR GUARANTEE PERIOD. ANY PLANTS REPLACED UNDER THIS GUARANTEE SHALL BE GUARANTEED FOR ONE FULL YEAR FROM THE DATE OF REPLACEMENT.
THE LANDSCAPE CONTRACTOR SHALL INSURE POSITIVE DRAINAGE IN ALL PLANTER AREAS PER CIVIL ENGINEER GRADING PLAN AFTER LANDSCAPE IMPROVEMENTS ARE COMPLETE.
REMOVE ALL WEEDS AND DEBRIS IN AND AROUND NEARLY INSTALLED PLANT MATERIAL. A PRE-PERMANENT HERBICIDE SHALL BE APPLIED AREAS PRIOR TO INSTALLATION OF MULCHES.

GreenDesign Landscape Architects, Inc.
Barbara M. Hester, AIA
1661 Parkway Drive
Lenoir, North Carolina
28540
773.838.1364
773.838.1364
BHU2008@hst.com

All drawings herein are the property of Tectonics Design Group and may not be reproduced or used in any manner without the written authorization of Tectonics Design Group.

DATE: 02/19/19
SUBMITAL: PERMIT SET

TECTONICS DESIGN GROUP
11455 Durham Court, Durham, North Carolina 27703
P.O. Box 1000, Durham, North Carolina 27703
Tel: 919.286.9900
Fax: 919.286.9901

LUXELOCKER
11455 Durham Court, Durham, North Carolina 27703
Consolidated Construction Co. Inc.
Asheboro, NC

DATE: 02/19/19
SUBMITAL: PERMIT SET

LANDSCAPE PLAN

MAINTENANCE
 THE IRRIGATION SHALL BE MAINTAINED TO ENSURE
 SUFFICIENT AND TIMELY WATERING NECESSARY FOR
 THE SURVIVAL OF ALL PLANT MATERIAL. A COPY
 OF THE APPROVED IRRIGATION PLAN WITH ANY
 ANNUAL CONDITIONS SHALL BE KEPT ON THE
 PROJECT SITE FOR INSPECTION. THE SYSTEM SHALL
 BE CHECKED YEARLY FOR CONTINUED OPERATION
 WITH THE ORIGINAL PLAN AND COMPONENTS
 ADJUSTED AND OR REPLACED AS PROVIDED FOR
 EFFICIENT OPERATION OF THE SYSTEM TO PROVIDE
 SUFFICIENT WATER TO ENSURE THE HEALTH OF THE
 PLANT MATERIAL.

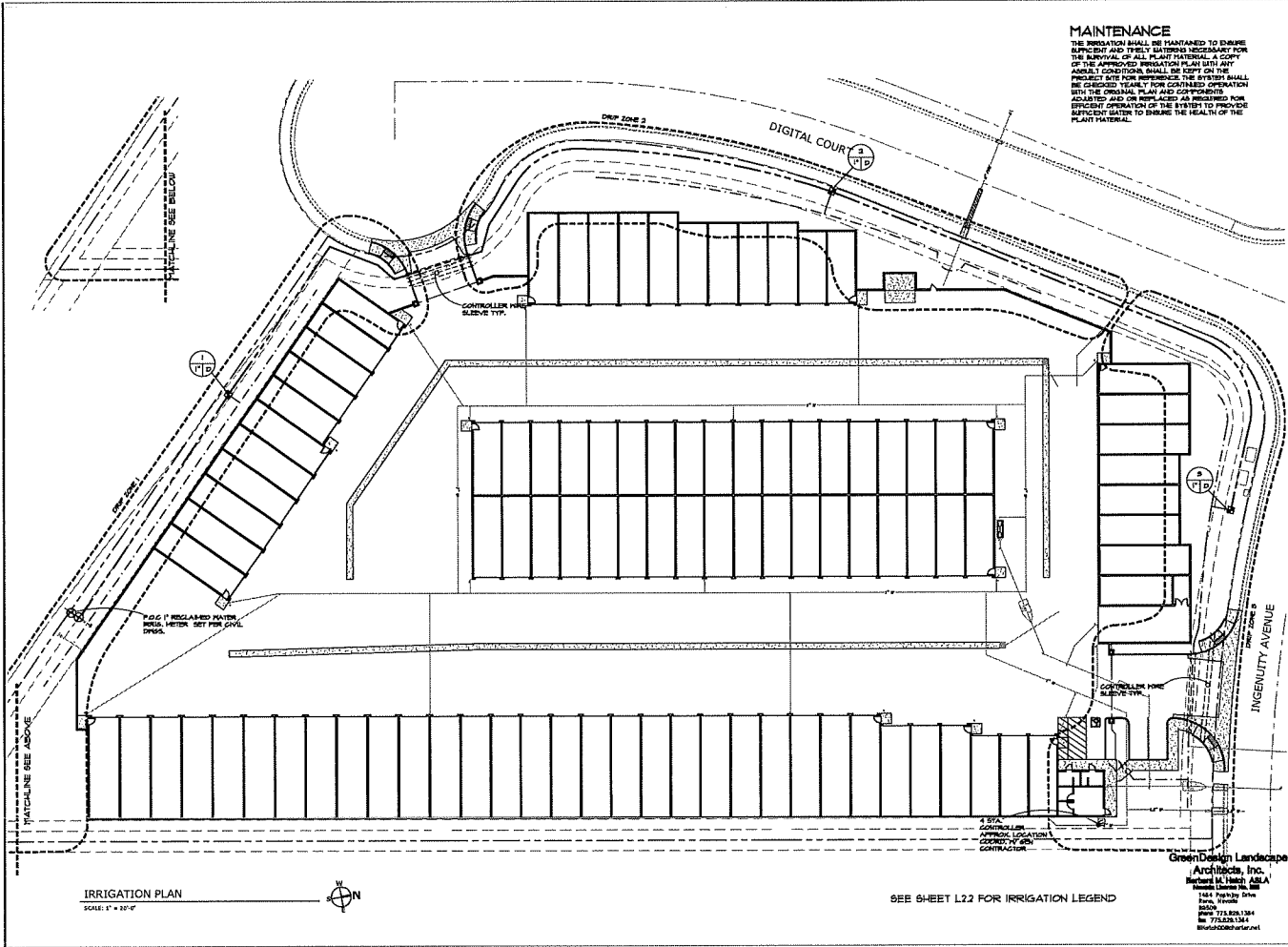

IRRIGATION PLAN
 SCALE: 1" = 20'-0"



SEE SHEET L22 FOR IRRIGATION LEGEND

Green Design Landscape
 Architects, Inc.
 Richard M. Hersh, AIA
 144 Parkway Drive
 Park, Nevada
 89020
 PH: 775.824.1364
 FX: 775.824.1344
 WWW.GDLDESIGN.COM

All drawings herein are the property of Tectonics Design Group and are not to be reproduced or used in any capacity without the written authorization of Tectonics Design Group.

CLIENT: TBD
 CHECKED/DATE: 04/26/2019
 DESIGNED BY: HANNAH W. HANCOCK AIA



**TECTONICS
 DESIGN GROUP**
 225 Nevada Blvd., 20th Floor, Nevada, Nevada 89101
 PH: 775.824.1364
 WWW.TECTONICSGROUP.COM

LUXELOCKER
 11455 Digital Court, Spanish Springs, Nevada
 Consolidated Construction Co Inc.
 Appleton, WI

DATE: 02/22/19
 SUBMITTAL: PERMIT SET

IRRIGATION PLAN

L2.1

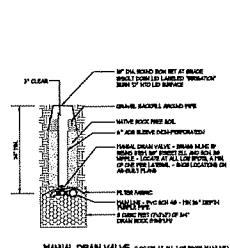

MANUAL DRAIN VALVE DETAIL AT ALL LOW POINTS INSTALLED NOT TO SCALE

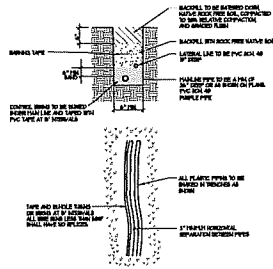

TRENCH DETAIL - LATERAL AND/OR MAINLINE NOT TO SCALE

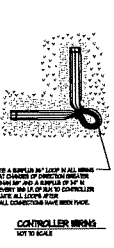

CONTROLLER WIRING NOT TO SCALE

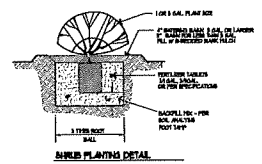

SHIELD PLATING DETAIL

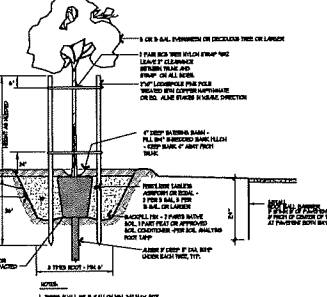

TRENCH PLANTING DETAIL

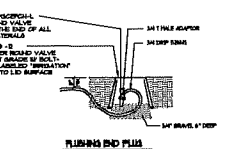

FLUSHING END PLUG NOT TO SCALE

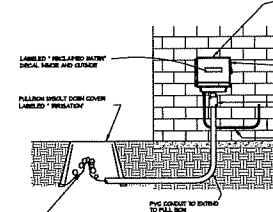

WALL MOUNT CONTROLLER DETAIL NOT TO SCALE

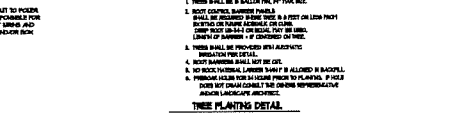

TRENCH DETAIL

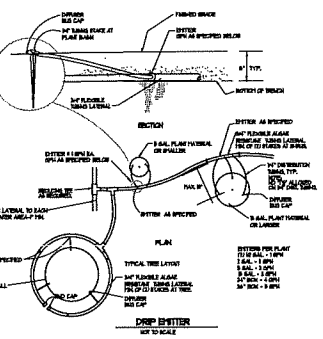

DRAIN EXISTING NOT TO SCALE

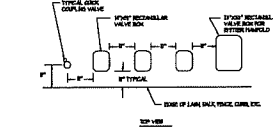

VALVE BOX NOT TO SCALE

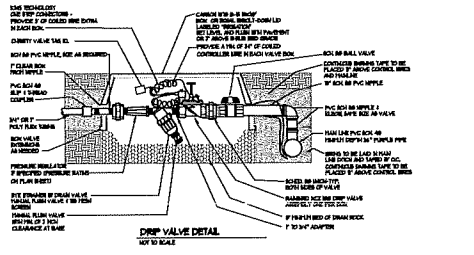

DRAIN VALVE DETAIL NOT TO SCALE

LANDSCAPE & IRRIGATION DETAILS

REFER TO RECLAIMED WATER NOTES SHEET L22

All drawings herein are the property of Tectonics Design Group and may not be reproduced or used in any capacity without the written authorization of Tectonics Design Group.

DATE: 12/13/13 SUBMITTAL: FORMAL SET

PROJECT: BARBARA M. HARTER ALA AREA

DESIGNER: TECTONICS DESIGN GROUP

11455 Dupont Court, Springville, Minnesota

Consolidated Construction Co. Inc.

Appleton, WI

LANDSCAPE & IRRIGATION DETAILS

L3.1

Property Owner Affidavit

Applicant Name: Spanish Springs Storage Partners LLC

The receipt of this application at the time of submittal does not guarantee the application complies with all requirements of the Washoe County Development Code, the Washoe County Master Plan or the applicable area plan, the applicable regulatory zoning, or that the application is deemed complete and will be processed.

STATE OF ^{Arizona} NEVADA)
COUNTY OF ^{Mohave} WASHOE)

I, Adam C. Pakes
(please print name)

being duly sworn, depose and say that I am the owner* of the property or properties involved in this application as listed below and that the foregoing statements and answers herein contained and the information herewith submitted are in all respects complete, true, and correct to the best of my knowledge and belief. I understand that no assurance or guarantee can be given by members of Planning and Building.

(A separate Affidavit must be provided by each property owner named in the title report.)

Assessor Parcel Number(s): 530-491-08, 530-491-09, 530-491-10

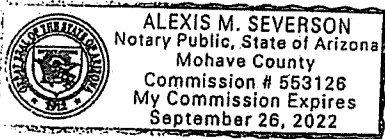

Printed Name Adam C. Pakes

Signed [Signature]

Address 3595 South Town Center Dr. 107

Las Vegas, NV 89135

Subscribed and sworn to before me this 11 day of October, 2019.

(Notary Stamp)

Alexis M. Severson
Notary Public in and for said county and state

My commission expires: Sept. 26, 2022

*Owner refers to the following: (Please mark appropriate box.)

- Owner
- Corporate Officer/Partner (Provide copy of record document indicating authority to sign.)
- Power of Attorney (Provide copy of Power of Attorney.)
- Owner Agent (Provide notarized letter from property owner giving legal authority to agent.)
- Property Agent (Provide copy of record document indicating authority to sign.)
- Letter from Government Agency with Stewardship

ENTITY INFORMATION**ENTITY INFORMATION****Entity Name:**

SPANISH SPRINGS STORAGE PARTNERS LLC

Entity Number:

E0069472019-1

Entity Type:

Domestic Limited-Liability Company (86)

Entity Status:

Active

Formation Date:

02/14/2019

NV Business ID:

NV20191123649

Termination Date:

Perpetual

Annual Report Due Date:

2/29/2020

Series LLC:**Restricted LLC:**

REGISTERED AGENT INFORMATION**Name of Individual or Legal Entity:**

LAW OFFICE OF MICHAEL R. MCNERNY, CHTD

Status:

Active

CRA Agent Entity Type:**Registered Agent Type:**

Commercial Registered Agent

NV Business ID:

NV20141676975

Office or Position:**Jurisdiction:****Street Address:**

7995 WEST SAHARA AVENUE SUITE 101, LAS VEGAS, NV, 89117, USA

Email Address:

MMCNERNY@MCNERNYLAW.COM

Mailing Address:**Individual with Authority to Act:****Contact Phone Number:****Fictitious Website or Domain Name:****PRINCIPAL OFFICE ADDRESS**

Address:

Mailing Address:

OFFICER INFORMATION

VIEW HISTORICAL DATA

| Title | Name | Address | Last Updated | Status |
|---------|-------------------------|---|--------------|--------|
| Manager | SUMMERLIN DESERT LLC | 1845 MCCULLOCH BLVD. STE. A6, LAKE HAVASU CITY, AZ, 86403, USA | 02/14/2019 | Active |

Page 1 of 1, records 1 to 1 of 1

[Filing History](#)

[Name History](#)

[Mergers/Conversions](#)

[Return to Search](#)

[Return to Results](#)

**UNANIMOUS WRITTEN CONSENT
OF THE MEMBERS
OF
SUMMERLIN DESERT, LLC**

The undersigned, being authorized to execute this resolution on behalf of Summerlin Asset Management LLC, and Desert Land Group LLC, who are each and all of the Members of Summerlin Desert LLC, a member-managed Nevada limited liability company (the "Company"), hereby unanimously resolve and consent to the adoption of, and adopt, the following resolution, effective as of *August 2*, 2016.

WHEREAS, on or about July 8th, 2016, the Members entered into an Operating Agreement controlling the governance and business affairs of the Company;

WHEREAS, under and in accordance with the Operating Agreement, the Members shall manage the Company by unanimous vote or written consent;

WHEREAS, Section 5.1 of the Operating Agreement provides that "the Managing Members may "appoint or discharge an agent or agents to conduct particular affairs of the business"; and

WHEREAS, the Managers have determined that it is necessary and expedient to appoint an authorized signatory for the Company, to execute all instruments, agreements, and other documents for and in the name of the Company;

NOW, THEREFORE, BE IT UNANIMOUSLY RESOLVED THAT the Adam C. Pakes is hereby authorized to execute by his signature all papers, instruments, contracts, letters, forms, deeds or other documents in the name of the Company in connection with any and all of its business affairs. The acts done and documents so executed shall be binding on the Company, unless and until this resolution is revoked, and notice of such revocation is provided to the recipient hereof.

Specimen Signature of Authorized Signatory: _____

RESOLVED FURTHER THAT, a copy of the above resolution duly certified as true by the authorized signatory of the Company may be furnished to such parties as may be required from time to time in connection with the above matter.

WHEREFORE, the undersigned affix their authorized signatures below

DESERT LAND GROUP, LLC
An Arizona limited liability company

By: _____

Name: *Mikael Gordon*

Title: *Manager*

Date: *8/2/16*

SUMMERLIN ASSET MANAGEMENT, LLC
A Nevada limited liability company

By: _____

Name: *Adam C. Pakes*

Title: *Manager*

Date: *8/2/16*

Washoe County Treasurer
 Tammi Davis

Account Detail

[Back to Account Detail](#)

[Change of Address](#)

[Print this Page](#)

CollectionCart

| Collection Cart | Items | Total | Checkout | View |
|-----------------|-------|--------|--------------------------|----------------------|
| | 0 | \$0.00 | | |

Pay Online

No payment due for this account.

Washoe County Parcel Information

| Parcel ID | Status | Last Update |
|-----------|--------|-----------------------|
| 53049108 | Active | 10/16/2019 2:07:32 AM |

Current Owner:
 SPANISH SPRINGS STORAGE PARTNERS LLC
 C/O MICHAEL R MCNERNY
 1845 MCCULLOCH BLVD N STE A6
 LAKE HAVASU CITY, AZ 86403

SITUS:
 11435 DIGITAL CT

Taxing District
 4000

Geo CD:

Legal Description

Lot 3 SubdivisionName _UNSPECIFIED Township 21 Range 20

Tax Bill (Click on desired tax year for due dates and further details)

| Tax Year | Net Tax | Total Paid | Penalty/Fees | Interest | Balance Due |
|----------------------|----------|------------|--------------|----------|-------------|
| 2019 | \$955.22 | \$964.78 | \$0.00 | \$0.00 | \$0.00 |
| 2018 | \$911.49 | \$911.49 | \$0.00 | \$0.00 | \$0.00 |
| 2017 | \$874.91 | \$874.91 | \$0.00 | \$0.00 | \$0.00 |
| 2016 | \$874.66 | \$874.66 | \$0.00 | \$0.00 | \$0.00 |
| 2015 | \$874.94 | \$874.94 | \$0.00 | \$0.00 | \$0.00 |
| Total | | | | | \$0.00 |

Disclaimer

- **ALERTS:** If your real property taxes are delinquent, the search results displayed may not reflect the correct amount owing. Please contact our office for the current amount due.
- For your convenience, online payment is available on this site. E-check payments are accepted without a fee. However, a service fee does apply for online credit card payments. See Payment Information for details.

Pay By Check

Please make checks payable to:
WASHOE COUNTY TREASURER

Mailing Address:
 P.O. Box 30039
 Reno, NV 89520-3039

Overnight Address:
 1001 E. Ninth St., Ste D140
 Reno, NV 89512-2845

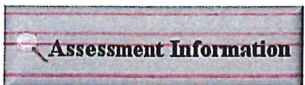
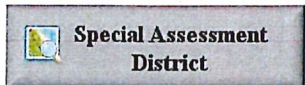

Washoe County Treasurer
 P.O. Box 30039, Reno, NV 89520-3039
 ph. (775) 328-2510 fax: (775) 328-2500
 Email: tax@washocounty.us

Washoe County Treasurer
 Tammi Davis

Account Detail

[Back to Account Detail](#)

[Change of Address](#)

[Print this Page](#)

CollectionCart

| Collection Cart | Items | Total | Checkout | View |
|-----------------|-------|--------|--------------------------|----------------------|
| | 0 | \$0.00 | | |

Pay Online

No payment due for this account.

Washoe County Parcel Information

| Parcel ID | Status | Last Update |
|-----------|--------|-----------------------|
| 53049109 | Active | 10/16/2019 2:07:32 AM |

Current Owner:
 SPANISH SPRINGS STORAGE PARTNERS LLC
 C/O MICHAEL R MCNERNY
 1845 MCCULLOCH BLVD N STE A6
 LAKE HAVASU CITY, AZ 86403

SITUS:
 11445 DIGITAL CT

Taxing District
 4000

Geo CD:

Legal Description

SubdivisionName _UNSPECIFIED Lot 2 Township 21 Range 20

Tax Bill (Click on desired tax year for due dates and further details)

| Tax Year | Net Tax | Total Paid | Penalty/Fees | Interest | Balance Due |
|----------------------|----------|------------|--------------|----------|---------------|
| 2019 | \$913.25 | \$922.39 | \$0.00 | \$0.00 | \$0.00 |
| 2018 | \$871.44 | \$871.44 | \$0.00 | \$0.00 | \$0.00 |
| 2017 | \$836.47 | \$836.47 | \$0.00 | \$0.00 | \$0.00 |
| 2016 | \$836.26 | \$836.26 | \$0.00 | \$0.00 | \$0.00 |
| 2015 | \$836.56 | \$836.56 | \$0.00 | \$0.00 | \$0.00 |
| Total | | | | | \$0.00 |

Disclaimer

- **ALERTS:** If your real property taxes are delinquent, the search results displayed may not reflect the correct amount owing. Please contact our office for the current amount due.
- For your convenience, online payment is available on this site. E-check payments are accepted without a fee. However, a service fee does apply for online credit card payments. See Payment Information for details.

Pay By Check

Please make checks payable to:
 WASHOE COUNTY TREASURER

Mailing Address:
 P.O. Box 30039
 Reno, NV 89520-3039

Overnight Address:
 1001 E. Ninth St., Ste D140
 Reno, NV 89512-2845

 **Payment Information**

 **Special Assessment District**

 **Installment Date Information**

 **Assessment Information**

Washoe County Treasurer
 P.O. Box 30039, Reno, NV 89520-3039
 ph: (775) 328-2510 fax: (775) 328-2500
 Email: tax@washoecounty.us

Washoe County Treasurer
 Tammi Davis

Account Detail

[Back to Account Detail](#)

[Change of Address](#)

[Print this Page](#)

CollectionCart

| Collection Cart | Items | Total |
|-----------------|-------|--------|
| | 0 | \$0.00 |

[Checkout](#) [View](#)

Pay Online

No payment due for this account.

Washoe County Parcel Information

| Parcel ID | Status | Last Update |
|-----------|--------|-----------------------|
| 53049110 | Active | 10/16/2019 2:07:32 AM |

Current Owner:
 SPANISH SPRINGS STORAGE PARTNERS LLC
 C/O MICHAEL R MCNERNY
 1845 MCCULLOCH BLVD N A6
 LAKE HAVASU CITY, AZ 86403

SITUS:
 11455 DIGITAL CT

Taxing District
 4000

Geo CD:

Legal Description

SubdivisionName _UNSPECIFIED Lot 1 Township 21 Range 20

Tax Bill (Click on desired tax year for due dates and further details)

| Tax Year | Net Tax | Total Paid | Penalty/Fees | Interest | Balance Due |
|----------------------|----------|------------|--------------|----------|---------------|
| 2019 | \$913.29 | \$922.43 | \$0.00 | \$0.00 | \$0.00 |
| 2018 | \$871.48 | \$871.48 | \$0.00 | \$0.00 | \$0.00 |
| 2017 | \$836.51 | \$836.51 | \$0.00 | \$0.00 | \$0.00 |
| 2016 | \$836.29 | \$836.29 | \$0.00 | \$0.00 | \$0.00 |
| 2015 | \$836.58 | \$836.58 | \$0.00 | \$0.00 | \$0.00 |
| Total | | | | | \$0.00 |

Disclaimer

- **ALERTS:** If your real property taxes are delinquent, the search results displayed may not reflect the correct amount owing. Please contact our office for the current amount due.
- For your convenience, online payment is available on this site. E-check payments are accepted without a fee. However, a service fee does apply for online credit card payments. See Payment Information for details.

Pay By Check

Please make checks payable to:
 WASHOE COUNTY TREASURER

Mailing Address:
 P.O. Box 30039
 Reno, NV 89520-3039

Overnight Address:
 1001 E. Ninth St., Ste D140
 Reno, NV 89512-2845

 **Payment Information**

 **Special Assessment District**

 **Installment Date Information**

 **Assessment Information**

Property Owner Affidavit

Applicant Name: Spanish Springs Storage Partners LLC

The receipt of this application at the time of submittal does not guarantee the application complies with all requirements of the Washoe County Development Code, the Washoe County Master Plan or the applicable area plan, the applicable regulatory zoning, or that the application is deemed complete and will be processed.

STATE OF NEVADA)
COUNTY OF WASHOE)

I, Adam C. Pakes (please print name)

being duly sworn, depose and say that I am the owner* of the property or properties involved in this application as listed below and that the foregoing statements and answers herein contained and the information herewith submitted are in all respects complete, true, and correct to the best of my knowledge and belief.

(A separate Affidavit must be provided by each property owner named in the title report.)

Assessor Parcel Number(s): 530-491-08, 530-491-09, 530-491-10

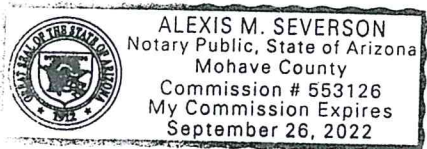

Printed Name Adam C. Pakes

Signed [Signature]

Address 3595 South Town Center Dr. 107

Las Vegas, NV 89135

(Notary Stamp)

Subscribed and sworn to before me this 11 day of October, 2019.

Alexis M. Severson
Notary Public in and for said county and state

My commission expires: Sept. 26, 2022

*Owner refers to the following: (Please mark appropriate box.)

- Owner
Corporate Officer/Partner
Power of Attorney
Owner Agent
Property Agent
Letter from Government Agency with Stewardship



Washoe County Treasurer
Tammi Davis

Washoe County Treasurer
P.O. Box 30039, Reno, NV 89520-3039
ph: (775) 328-2510 fax: (775) 328-2500
Email: tax@washocounty.us

[TREASURER HOME PAGE](#)

[WASHOE COUNTY HOME PAGE](#)

[Tax Search](#)

[Checkout](#)

CollectionReceipt



Checkout Receipt

Date: 10/11/2019 2:22:24 PM
Approval: 26637973
Account: *****2564
Payment Type: eCheck

| Description | Amount Paid |
|------------------------|-------------|
| Tax Payment - 53049110 | \$922.43 |
| Tax Payment - 53049108 | \$964.78 |
| Tax Payment - 53049109 | \$922.39 |

| | |
|-------------|------------|
| Service Fee | \$2,809.60 |
| Total Paid | \$0.00 |
| | \$2,809.60 |



NOTE: To print a copy of this receipt, please right-click anywhere on this webpage and select Print from the pull-down menu.

Washoe County Treasurer
 Tammi Davis

Bill Detail

[Back to Account Detail](#)

[Change of Address](#)

[Print this Page](#)

Pay By Check

Please make checks payable to:
WASHOE COUNTY TREASURER

Mailing Address:
 P.O. Box 30039
 Reno, NV 89520-3039

Overnight Address:
 1001 E. Ninth St., Ste D140
 Reno, NV 89512-2845

Change of Address

All requests for a mailing address change must be submitted in writing, including a signature (unless using the online form).

To submit your address change online [click here](#)

Address change requests may also be faxed to: (775) 328-3642

Address change requests may also be mailed to:
 Washoe County Assessor
 1001 E 9th Street
 Reno, NV 89512-2845

| Washoe County Parcel Information | | |
|---|----------------|-----------------------------------|
| Parcel ID | Status | Last Update |
| 53049109 | Active | 10/11/2019 2:07:54 AM |
| Current Owner: SPANISH SPRINGS STORAGE PARTNERS LLC 10781 W TWAIN AVE LAS VEGAS, NV 89135 | | SITUS: 11445 DIGITAL CT |
| Taxing District 4000 | Geo CD: | |
| Legal Description | | |
| SubdivisionName _UNSPECIFIED Lot 2 Township 21 Range 20 | | |

| Installments | | | | | | |
|-------------------|-----------|----------|-----------------|---------------|---------------|-----------------|
| Period | Due Date | Tax Year | Tax | Penalty/Fee | Interest | Total Due |
| INST 1 | 8/19/2019 | 2019 | \$228.42 | \$9.14 | \$0.00 | \$237.56 |
| INST 2 | 10/7/2019 | 2019 | \$228.28 | \$0.00 | \$0.00 | \$228.28 |
| INST 3 | 1/6/2020 | 2019 | \$228.28 | \$0.00 | \$0.00 | \$228.28 |
| INST 4 | 3/2/2020 | 2019 | \$228.27 | \$0.00 | \$0.00 | \$228.27 |
| Total Due: | | | \$913.25 | \$9.14 | \$0.00 | \$922.39 |

| Tax Detail | | | |
|---|-------------------|---------------------|-----------------|
| | Gross Tax | Credit | Net Tax |
| State of Nevada | \$101.40 | (\$53.49) | \$47.91 |
| Truckee Meadows Fire Dist | \$322.08 | (\$169.91) | \$152.17 |
| Washoe County | \$830.07 | (\$437.89) | \$392.18 |
| Washoe County Sc | \$679.06 | (\$358.21) | \$320.85 |
| SPANISH SPRINGS WATER BASIN | \$0.14 | \$0.00 | \$0.14 |
| Total Tax | \$1,932.75 | (\$1,019.50) | \$913.25 |

| Payment History |
|--------------------------|
| No Payment Records Found |

The Washoe County Treasurer's Office makes every effort to produce and publish the most current and accurate information possible. No warranties, expressed or implied, are provided for the data herein, its use, or its interpretation. If you have any questions, please contact us at (775) 328-2510 or tax@washoecounty.us

This site is best viewed using Google Chrome, Internet Explorer 11, Mozilla Firefox or Safari.

Washoe County Treasurer
Tammi Davis

Washoe County Treasurer
P.O. Box 30039, Reno, NV 89520-3039
ph: (775) 328-2510 fax: (775) 328-2500
Email: tax@washoecounty.us

Bill Detail

[Back to Account Detail](#)
[Change of Address](#)
[Print this Page](#)

Washoe County Parcel Information

| Parcel ID | Status | Last Update |
|-----------|--------|-----------------------|
| 53049108 | Active | 10/11/2019 2:07:54 AM |

Current Owner:
SPANISH SPRINGS STORAGE PARTNERS LLC
10781 W TWAIN AVE
LAS VEGAS, NV 89135

SITUS:
11435 DIGITAL CT

Taxing District:
4000

Geo CD:

Legal Description
Lot 3 SubdivisionName _UNSPECIFIED Township 21 Range 20

Pay By Check

Please make checks payable to:
WASHOE COUNTY TREASURER

Mailing Address:
P.O. Box 30039
Reno, NV 89520-3039

Overnight Address:
1001 E. Ninth St., Ste D140
Reno, NV 89512-2845

Change of Address

All requests for a mailing address change must be submitted in writing, including a signature (unless using the online form).

To submit your address change online [click here](#)

Address change requests may also be faxed to: (775) 328-3642

Address change requests may also be mailed to:
Washoe County Assessor
1001 E 9th Street
Reno, NV 89512-2845

Installments

| Period | Due Date | Tax Year | Tax | Penalty/Fee | Interest | Total Due |
|-------------------|-----------|----------|-----------------|---------------|---------------|-----------------|
| INST 1 | 8/19/2019 | 2019 | \$238.91 | \$9.56 | \$0.00 | \$248.47 |
| INST 2 | 10/7/2019 | 2019 | \$238.77 | \$0.00 | \$0.00 | \$238.77 |
| INST 3 | 1/6/2020 | 2019 | \$238.77 | \$0.00 | \$0.00 | \$238.77 |
| INST 4 | 3/2/2020 | 2019 | \$238.77 | \$0.00 | \$0.00 | \$238.77 |
| Total Due: | | | \$955.22 | \$9.56 | \$0.00 | \$964.78 |

Tax Detail

| | Gross Tax | Credit | Net Tax |
|---|-------------------|---------------------|-----------------|
| State of Nevada | \$106.07 | (\$55.97) | \$50.10 |
| Truckee Meadows Fire Dist | \$336.94 | (\$177.77) | \$159.17 |
| Washoe County | \$868.39 | (\$458.16) | \$410.23 |
| Washoe County Sc | \$710.39 | (\$374.81) | \$335.58 |
| SPANISH SPRINGS WATER BASIN | \$0.14 | \$0.00 | \$0.14 |
| Total Tax | \$2,021.93 | (\$1,066.71) | \$955.22 |

Payment History

No Payment Records Found

The Washoe County Treasurer's Office makes every effort to produce and publish the most current and accurate information possible. No warranties, expressed or implied, are provided for the data herein, its use, or its interpretation. If you have any questions, please contact us at (775) 328-2510 or tax@washoecounty.us

This site is best viewed using Google Chrome, Internet Explorer 11, Mozilla Firefox or Safari.

Washoe County Treasurer
 Tammi Davis

Bill Detail

[Back to Account Detail](#)

[Change of Address](#)

[Print this Page](#)

Pay By Check

Please make checks payable to:
WASHOE COUNTY TREASURER

Mailing Address:
 P.O. Box 30039
 Reno, NV 89520-3039

Overnight Address:
 1001 E. Ninth St., Ste D140
 Reno, NV 89512-2845

Change of Address

All requests for a mailing address change must be submitted in writing, including a signature (unless using the online form).

To submit your address change online [click here](#)

Address change requests may also be faxed to: (775) 328-3642

Address change requests may also be mailed to: Washoe County Assessor 1001 E 9th Street Reno, NV 89512-2845

Washoe County Parcel Information

| Parcel ID | Status | Last Update |
|---|----------------|-----------------------------------|
| 53049110 | Active | 10/11/2019 2:07:54 AM |
| Current Owner: SPANISH SPRINGS STORAGE PARTNERS LLC 3595 SOUTH TOWN CENTER DR 107 LAS VEGAS, NV 89135 | | SITUS: 11455 DIGITAL CT |
| Taxing District: 4000 | Geo CD: | |
| Legal Description | | |
| SubdivisionName _UNSPECIFIED Lot 1 Township 21 Range 20 | | |

Installments

| Period | Due Date | Tax Year | Tax | Penalty/Fee | Interest | Total Due |
|-------------------|-----------|----------|-----------------|---------------|---------------|-----------------|
| INST 1 | 8/19/2019 | 2019 | \$228.43 | \$9.14 | \$0.00 | \$237.57 |
| INST 2 | 10/7/2019 | 2019 | \$228.29 | \$0.00 | \$0.00 | \$228.29 |
| INST 3 | 1/6/2020 | 2019 | \$228.29 | \$0.00 | \$0.00 | \$228.29 |
| INST 4 | 3/2/2020 | 2019 | \$228.28 | \$0.00 | \$0.00 | \$228.28 |
| Total Due: | | | \$913.29 | \$9.14 | \$0.00 | \$922.43 |

Tax Detail

| | Gross Tax | Credit | Net Tax |
|---|-------------------|---------------------|-----------------|
| State of Nevada | \$101.40 | (\$53.49) | \$47.91 |
| Truckee Meadows Fire Dist | \$322.09 | (\$169.91) | \$152.18 |
| Washoe County | \$830.09 | (\$437.89) | \$392.20 |
| Washoe County Sc | \$679.08 | (\$358.22) | \$320.86 |
| SPANISH SPRINGS WATER BASIN | \$0.14 | \$0.00 | \$0.14 |
| Total Tax | \$1,932.80 | (\$1,019.51) | \$913.29 |

Payment History

No Payment Records Found

The Washoe County Treasurer's Office makes every effort to produce and publish the most current and accurate information possible. No warranties, expressed or implied, are provided for the data herein, its use, or its interpretation. If you have any questions, please contact us at (775) 328-2510 or tax@washoecounty.us

This site is best viewed using Google Chrome, Internet Explorer 11, Mozilla Firefox or Safari.

**SPANISH SPRINGS STORAGE PARTNERS LLC
OPERATING AGREEMENT**

THIS LIMITED LIABILITY COMPANY OPERATING AGREEMENT (“Agreement”) is made and entered into as of this Day of March, 2019, by, among and between those persons listed at Exhibit 1 to this Agreement and every person or entity hereafter admitted as a Member pursuant to this Agreement (the “Members”), and Summerlin Desert LLC, a Nevada limited liability company (the “Manager”). Prior to this Agreement, the Members and Manager have caused to be formed the Limited Liability Company named above under the laws of the State of Nevada. Accordingly, in consideration of the conditions and mutual promises contained herein, they agree as follows:

**ARTICLE I
Company Formation and Registered Agent**

1.1 **FORMATION.** The Members and Manager hereby form a Limited Liability Company (the “Company”) subject to the provisions of the Limited Liability Company Chapter 86 of Nevada Revised Statutes, as currently in effect as of this date. A Certificate of Formation shall be filed with the Secretary of State. The Company shall be managed by the Manager.

1.2 **NAME.** The name of the Company shall be: Spanish Springs Storage Partners, LLC

1.3 **TERM.** The Company shall continue until the earlier of the occurrence of any of the following:

- (a) It is dissolved by the Manager, with the consent of those Members holding at least 50% of the total membership equity in the Company, or if the Company shall have no assets, then by the Manager with or without the consent of any Member;
- (b) Any event occurs which makes it unlawful for the business of the Company to be carried on by the Members; or
- (c) Any other event causing dissolution of a Limited Liability Company under the laws of the State of Nevada.

1.4 **PURPOSE.** The Company is founded to pursue any lawful business purpose. Without limiting the foregoing, the Members intend that the Company’s primary purpose shall be the acquisition, construction, operation or sale of a certain planned condominium-style self-storage facility located in Spanish Springs, Nevada (the “Project”).

1.5 **PRINCIPAL PLACE OF BUSINESS.** The Principal Place of Business of the Company shall be the offices of the Manager, 1845 McCulloch Blvd. Ste. A6, Lake Havasu City, Arizona 86403, or any place the Manager may designate from time to time.

1.6 **REGISTERED OFFICE AND AGENT.** The location of the registered office of the Company is currently 335 W. First St., Reno Nevada 89503. The registered agent shall be Edmund J. Gorman, Jr. The Manager may change the registered agent or registered address of the company at any time.

**ARTICLE 2
Members**

2.1 **ISSUANCE OF MEMBERSHIP INTERESTS.** The undersigned Members and Manager hereby authorize the issuance of, and issue, the Membership Interests in the Company as set out from time to

time in Exhibit 1. A copy of Exhibit 1, as duly amended by the Manager, shall serve as conclusive evidence of the interest of each member.

2.2 COMPANY EQUITY. The membership interests representing the equity of the Company shall be issued pro rata to Members making capital contributions in cash. Members shall receive redemption of their capital contribution from Company proceeds before any other Members are paid a share of profits. Members shall also be entitled to a “preferred return” of 8% per annum on the value of their capital contribution(s), simple interest (as further set forth in Article 5), payable from available funds at the discretion of the Manager. Finally, Members shall each be entitled to a distribution of profits according to their pro rata share of Company equity, after accounting for a Manager’s fee of 50% of Net Profits (as defined in Article 5).

2.3 GOVERNANCE BY MANAGER. The Members hereby vest all governance authority of the Company in the Manager as set out in Article 4 of this Agreement. The Members waive any rights to manage or govern the affairs of the Company except as set out in this Agreement.

2.4 RIGHTS OF MEMBERS. Each member shall be entitled to such distributions of profits and other proceeds as required by this Agreement or as the Manager may approve, according to their class and in proportion to the Member’s total equity interest in the Company as set out in Exhibit 1, as amended from time to time.

2.5 ADMISSION OF ADDITIONAL MEMBERS. The Manager may admit new members or create additional classes of members as the Manager may choose. Admitting new members may be necessary to raise additional funds for the business of the Company. The Members acknowledge and agree that existing or additional Members making further contributions of capital may entitle them Membership, which may dilute current Members’ interests. The Manager shall not admit new members in such a way as to cause the equity of any initial current Members to be disproportionately diluted, unless the Manager obtains the written consent of those Members holding a majority of the equity interests of the Company. All later-admitted Members must make a contribution of capital in cash, and the equity interests of prior Members will be diluted pro rata.

2.6 TRANSFER OF MEMBERSHIP INTERESTS. No assignee of the whole or any portion of a Member’s Interest in the Company shall have the right to become a substituted Member in place of an assignor, unless the following conditions are first met:

- (a) The assignor has held its membership interest for a period of more than 365 days;
- (b) The assignor shall designate its intention in a written instrument of assignment, which shall be in a form and substance reasonably satisfactory to the Manager;
- (c) The transferring Member shall first obtain written consent of the Manager to the substitution. The Manager shall not unreasonably withhold its consent, but the Manager shall withhold its consent to the extent necessary to prohibit transfers that could cause the Company to be classified as a publicly traded partnership under the Internal Revenue Code, an Investment Company under the Investment Company Act of 1940, or would require the registration of securities under the Securities Act of 1933, or the laws of any state. The Manager will also withhold consent if it determines that the sale or transfer will otherwise jeopardize the continued ability of the Company to qualify as a “partnership” for federal income tax purposes or that the sale or transfer may violate any applicable securities laws (including any investment suitability standards);

- (d) The assignor and assignee named therein shall execute and acknowledge any other instruments as the Manager may deem necessary or desirable to effect the substitution, including, but not limited to, a power of attorney;
- (e) The assignor shall surrender his membership certificate(s), if any, to the Manager;
- (f) The assignee shall accept, adopt and approve in writing all of the terms and provisions of this Agreement as the same may have been amended;
- (g) The assignee shall pay or, at the election of the Manager, obligate himself to pay all reasonable expenses connected with the substitution, including but not limited to reasonable attorneys' fees associated therewith; and
- (h) The Company has received, if required by the Manager, a legal opinion satisfactory to the Manager that the transfer will not violate the registration provisions of the Securities Act of 1933, as amended or any applicable state securities laws, which opinion shall be furnished at the Investor's expense.

The Manager shall then alter Exhibit 1 of this Operating Agreement to reflect the membership interest of the assignee, who shall have all the rights, privileges, and obligations set out in this Agreement. Notwithstanding the foregoing, the Manager, may, at its sole discretion, waive any restriction on transfer, so long as the Manager is satisfied that such transfer would not violate any provision of the Internal Revenue Code or applicable securities laws.

2.7 CONFIDENTIALITY. A Member shall not, either directly or indirectly, in whole or in part, use or disclose to any person, firm, corporation, or other entity, any of the Company's confidential information, which may include (but not be limited to) records, plans, documents, drawings, methods, processes, financial information, market data or analyses, or any other information provided to a Member by the Company not available to the general public. Information about the Company assets that is revealed to a Member is confidential and Members shall take reasonable steps to ensure its non-disclosure to or by any third party.

ARTICLE 3 Capital, Profits, Losses and Distributions

3.1 CAPITAL CONTRIBUTIONS. Each Member has made, or hereby covenants to make, a contribution of capital to the Company in the form of cash or warrants, or some combination thereof, in the discretion of the Manager, with a total aggregate value of all Member contributions of not less than \$1,000,000.00. The particular contribution of each Member is set out in Exhibit 1 below.

3.2 ADDITIONAL CONTRIBUTIONS. No Member shall be obligated to make any additional contribution to the Company's capital. However, if Members are unable to meet a call for additional capital, the Manager may admit new Members into the Company or permit additional investments by other current Members, which may dilute a Member's interest. Members will be entitled to make additional contributions of capital to maintain their percent share of equity before additional contributions are sought from new or current Members.

3.3 WITHDRAWAL OF CAPITAL CONTRIBUTIONS. Except as set out in Article 5 below, no Member will have the right to withdraw or receive any return of its capital contribution without the consent of the Manager, which shall not be unreasonably withheld, but which may be subject to the Manager's ability to find a buyer for the Member's share. Under circumstances requiring the return of any

Contribution, no Member will have the right to receive particular property other than cash, and the Company reserves the right to refund a capital contribution in installments in an amount which, in the judgment of the Manager, will not threaten the ongoing operations of the Company, or render the Company unable to meet its anticipated obligations as they come due. If the Manager does consent to a withdrawal of a Member's Capital, that Member shall not be entitled to any payment of the 8% "preferred return" set out in Sections 5.2 and 5.3 of this Agreement.

ARTICLE 4 Management

4.1 MANAGEMENT OF THE BUSINESS. The Company shall be managed by, and the Members hereby irrevocably appoint, Summerlin Desert LLC, a Nevada limited liability company, as Manager ("Manager"). By this Agreement, Summerlin Desert LLC accepts this appointment as Manager, and in that capacity shall be bound by the applicable terms of this Agreement. The Manager shall have the authority to bind the Company in contract and to negotiate financial instruments on behalf of the company, to purchase and convey real or personal property, to incur indebtedness, and to conduct all other activities incidental to the business of the Company. The Manager may appoint or discharge an agent or agents to conduct particular affairs of the business. The Manager shall serve until it resigns, is dissolved, or is removed by a Court of competent jurisdiction. When so removed, the Members shall have the power to appoint a substitute Manager by a majority vote of the Members' interests, with each Member's vote being in proportion to the Member's ownership interest in the Company's equity.

4.2 POWERS OF THE MANAGER. The Manager is authorized on the Company's behalf to make all decisions as to:

- (a) the sale, development lease or other disposition of the Company's assets;
- (b) the purchase or other acquisition of other assets of all kinds;
- (c) the management of all or any part of the Company's assets;
- (d) the compromise or release of any of the Company's claims or debts; and,
- (e) the employment of persons, agents, firms or corporations for the operation and management of the company's business.

4.3 POWER TO NEGOTIATE INSTRUMENTS. In the exercise of management powers, the Manager is further authorized to execute and deliver:

- (a) all contracts, conveyances, assignments leases, sub-leases, franchise agreements, licensing agreements, management contracts and maintenance contracts covering or affecting the Company's assets;
- (b) all checks, drafts and other orders for the payment of the Company's funds;
- (c) all promissory notes, loans, security agreements and other similar documents; and,
- (d) all other instruments of any other kind relating to the Company's affairs, whether like or unlike the foregoing.

4.4 EXCULPATION AND RELEASE. The liability of the Members and the Manager shall be limited as provided under the laws of the State of Nevada. The Company will release and hold harmless the Members and the Manager from any and all liability incurred by act or omission in the conduct of the business, to the maximum extent permitted by law. Such indemnity shall not extend to conduct in knowing violation of this agreement, or for which a Member is convicted under criminal statutes, or which constitutes intentional or willful unlawful conduct.

4.5 INDEMNITY OF AGENTS. The Company shall indemnify any person who was or is a party defendant or is threatened to be made a party defendant, pending or completed action, suit or proceeding, whether civil, criminal, administrative, or investigative (other than an action by or in the right of the Company) by reason of the fact that he is or was a Member, Manager, employee, or agent of the Company, or is or was serving at the request of the Company, for instant expenses (including attorney's fees), judgments, fines, and amounts paid in settlement actually and reasonably incurred in connection with such action, suit or proceeding if the Members determine that he or she acted in good faith and in a manner he or she reasonably believed to be in or not opposed to the best interest of the Company, and with respect to any criminal action proceeding, had no reasonable cause to believe his/her conduct was unlawful. The termination of any action, suit, or proceeding by judgment, order, settlement, conviction, or upon a plea of "no lo contendere" or its equivalent, shall not in itself create a presumption that the person did or did not act in good faith and in a manner which he reasonably believed to be in the best interest of the Company.

4.6 NOMINEE. Title to the Company's assets shall be held in the Company's name or in the name of any nominee that the Manager may designate. The Manager shall have power to enter into a nominee agreement with any such person, and such agreement may contain provisions indemnifying the nominee, except for his willful misconduct.

4.7 COMPENSATION. As Compensation for its services, the Manager shall be entitled to:

(a) Eight Percent (8%) of the total actual costs of the development of the project, not including the costs of acquiring land, financing costs, or debt service, which shall be drawn from time to time as such costs are incurred; and

(b) Fifty Percent (50%) of the Net Profits of the Company distributable to Members, after accounting for necessary and ordinary business expenses and payment of Members' "preferred return," as more fully set out in Section 5.2 below. The Manager shall also be reimbursed for any costs advanced in the course of the Company's business.

4.8 CONFLICT OF INTEREST. Members understand and agree that Manager's employees and principals, and the family members and associates of employees and principals, may be Members of the Company, or may have business interests that compete with the interests, opportunities, or business of the Company. The Members waive any claim or defense based upon the existence of any such conflict.

ARTICLE 5

Profits, Losses and Distributions

5.1 PROFITS/LOSSES. For financial accounting and tax purposes the Company's net profits or net losses shall be determined on a quarterly basis. The Company's accounting period shall be the calendar year.

5.2 DISTRIBUTIONS FROM OPERATIONS. Net proceeds from Company operations shall be distributed from time to time, in the discretion of the Manager, in the following order and in the following manner as funds are available:

- (a) To the payment of all expenses, debts and liabilities of the Company then being due and payable to third party creditors, and in reimbursement to the Manager for any necessary and ordinary business expenses of the Company advanced by the Manager, and the Manager's fee of 8% of actual costs of the Company's business as provided in Section 4.7(a), above (not to include the purchase price of the Company's real estate, debt service, or other financing costs), payable at the time such costs are paid to third parties;
- (b) To an account for use as reserve funds for anticipated expenses, debts and liabilities to come due, in an amount that the Manager determines, in its sole discretion, is necessary or expedient to carry on the business of the Company;
- (c) To all Members, pro rata, until all Members' capital contributions are repaid in full;
- (d) To each of the Members in payment of a 8% per annum return on their capital contribution amounts, to the extent such payments have accrued on a monthly basis from the date of contribution through the earlier of the date of sale or the date of completion of the entire Project (i.e., the issuance of a permanent Certificate of Occupancy), until such accrued interest is paid in full;
- (f) The remainder, which shall be deemed "Net Profits," shall be distributed pro rata to all Members according to their percentage interest in the equity of the Company as set out in Exhibit 1, provided that 50% of such Net Profits payable to the Members shall be paid to the Manager, in accordance with Section 4.7(b) above.

ARTICLE 6

Accounts of Costs and Expenses

6.1 BOOKS. The Manager shall maintain (or cause to be maintained) complete and accurate books of account of the Company's affairs available to any Member. Such books shall be kept on such method of accounting as the Manager shall select.

6.2 RECORDS. The Manager shall cause the Company to keep at its registered address, or at another location known to the registered agent, the following:

- (a) a current list of the full name and the last known street address of each Member;
- (b) a copy of the Articles of Organization and a copy of this Agreement and all amendments, including Exhibit 1;
- (c) copies of the Company's federal, state and local income tax returns and reports, if any, for the three most recent years;
- (d) copies of any financial statements of the limited liability company produced in the course of business for the three most recent years.

6.3 REPORTS. The Manager shall prepare and send to any member, upon request, a current statement of income and expenses of the Company.

6.4 **REIMBURSEMENT.** The Company shall reimburse the Manager or any duly authorized agent or delegee of the Manager for all direct out-of-pocket expenses incurred by it in managing the Company and conducting its business activities.

ARTICLE 7 Transfers and Termination

7.1 **DEATH, RESIGNATION, OR BANKRUPTCY.** In the event of a death, resignation, or bankruptcy of any Member, said Member shall have no rights to participate in the management of the Company, and any remaining Members shall have the right to continue the business of the Company. Any right or interest in the Company passing to another or required to be liquidated as a result of the death or bankruptcy of a Member shall be, at the Manager's election, paid out under such terms as will not threaten the continued operation of the business, rather than through liquidation of company assets.

7.2 **ASSIGNMENT.** If a Member sells or assigns an interest in the Company in contravention of this Agreement, the purchaser or assignee shall only be entitled to receive the share of the profits or other compensation by way of income and the return of contributions to which that Member would otherwise be entitled, and shall have no right to participate in the governance of the Company through voting or any other rights provided for in this Agreement. Furthermore, such Assignee shall not be entitled to any of the 8% "preferred return" otherwise payable to the Members.

ARTICLE 8 Miscellaneous Legal Provisions

8.1 **MERGER CLAUSE.** The text of this Agreement, including those terms used as subject headings, constitute the full, complete, and integrated agreement of the parties concerning the Company as of the date of this Agreement. All other prior agreements concerning the Company, including any prior operating agreements, or drafts thereof, are hereby rescinded and revoked. This Agreement replaces, supersedes, or voids any previous agreement between the parties relating to the Company. Where provisions of this Agreement are inconsistent with prior or contemporaneous statements made by the Company or its agent(s), the provisions of this Agreement shall control.

8.2 **CHOICE OF LAW.** This Agreement is intended to be interpreted according to the laws of the State of Nevada, including that body of laws known as Choice of Laws, unless application of such body of laws would require a court of competent jurisdiction to apply the laws of another state, in which case Nevada's Choice of Laws shall not apply to the extent, and only to the extent, that they require the court to apply the laws of another state.

8.3 **CHOICE OF VENUE.** With respect to any dispute arising from this Agreement, the Members each hereby agree that such dispute shall be brought in the State or Federal Courts located in (or otherwise having primary jurisdiction over) Spanish Springs, Nevada. Each Member submits to the personal jurisdiction of said Courts, and further agrees that such venue is convenient and proper.

8.4 **ATTORNEY FEES.** Any Member who brings an action in any Court on his own behalf, or on behalf of the Company, that is inconsistent with this Agreement, including but not limited to the provisions in this Article 8, and the indemnity and release provisions of Article 4, shall pay the attorney fees and costs of the Company and every other Member or Manager made a party to an action or otherwise called to respond to or participate in such action, regardless of the outcome of the proceeding.

8.5 **AMENDMENTS.** This Agreement may be amended by a vote of the members holding more than 50% of the equity interests in the Company, except: (i) Exhibit 1, which may be amended by the Manager from time to time as new Members and classes of Members are created pursuant to the Manager's powers set out herein; and (ii) amendments which are, in the discretion of the Manager, necessary to clarify the terms of this Agreement and do not substantially alter the interests of the Members, or to bring the Company into compliance with applicable laws or regulations.

8.6 **SEVERABILITY.** Should any part of this Agreement be rendered or declared invalid by a court of competent jurisdiction with respect to such matters, the invalidation of such part or portion of this Agreement should not invalidate the remaining portions thereof, and they shall remain in full force and effect.

8.7 **COUNTERPARTS.** This agreement may be executed in counterparts, and each signed counterpart shall be deemed an original.

ARTICLE 9
Execution

We, the undersigned, individually and on behalf of the Company, have read, understand, and agree to abide by the terms of this Agreement.

SUMMERLIN DESERT LLC
As MANAGER

By: _____
Date: _____

**SPANISH SPRINGS STORAGE PARTNERS LLC
OPERATING AGREEMENT
Member's Signature Page**

The undersigned has read, understands, and agrees to abide by the terms of this Agreement.

Name: _____

Date: _____

Initial Capital Investment:

Exhibit 1

**SPANISH SPRINGS STORAGE PARTNERS LLC
OPERATING AGREEMENT
SCHEDULE OF MEMBER INTERESTS**

As of the _____ day of _____, 201__ the following is a list of Members of the Company:

MEMBERS

| NAME | ADDRESS | CAPITAL CONTRIBUTION | OWNERSHIP INTEREST BY PER CENT: |
|-------------|----------------|-----------------------------|--|
|-------------|----------------|-----------------------------|--|

| | | | |
|--------------|--|--|-------------|
| Total | | | 100% |
|--------------|--|--|-------------|

Total of Capital Contributions in Cash: _____

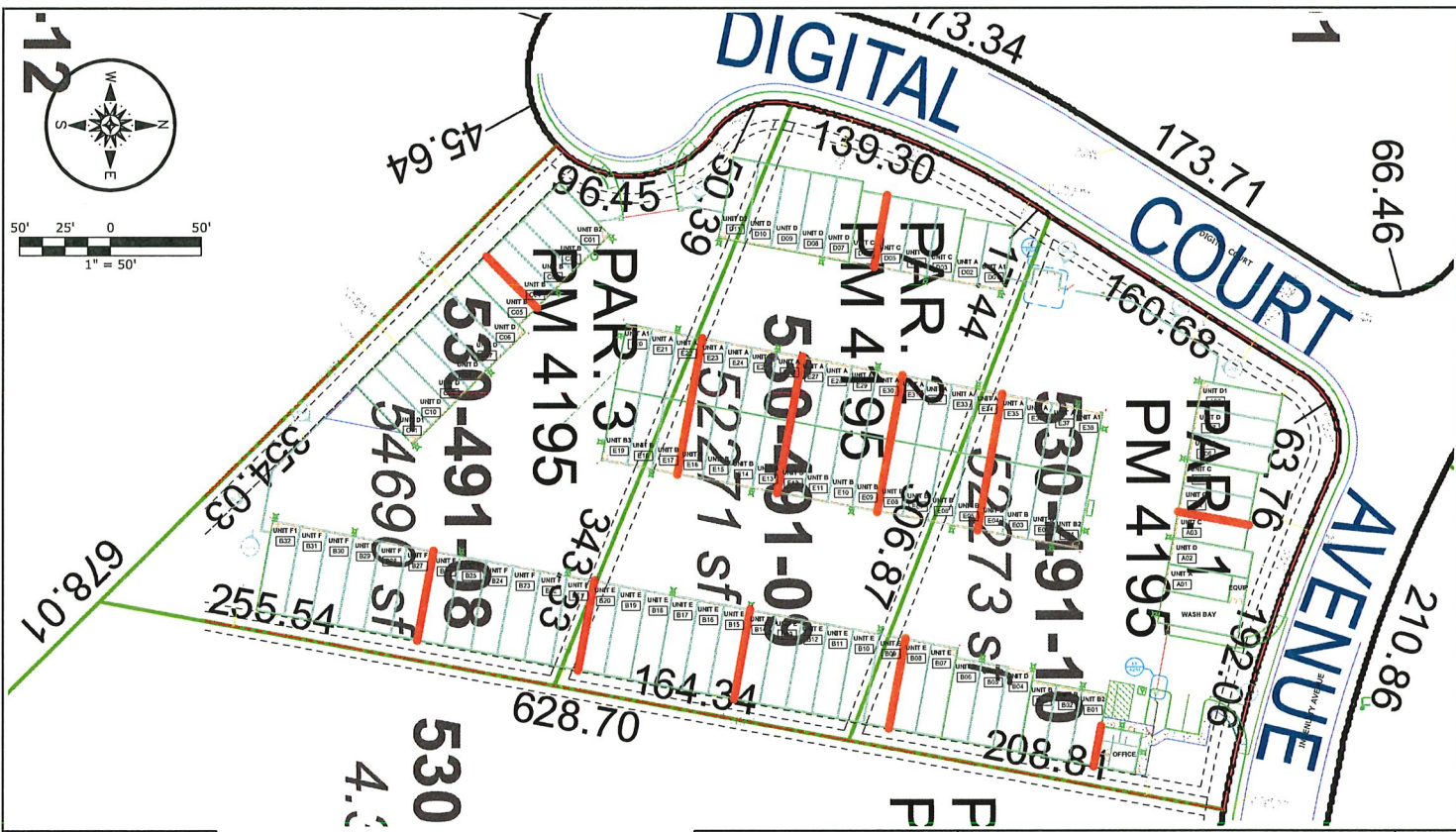

US GEOMATICS
 P.O. Box 3299
 648 Lander Street
 Reno, NV 89505
 P. 775.786.5111
 www.usgeomatcs.com
 info@usgeomatcs.com

Project No: 184-03-19
 Date: 10-15-2018
 Drawn by: DM
 Designed by: DM
 Checked by: ADV

Horiz. scale: 1" = 50'
 Vertical scale:
 Projection:
 Horiz. datum: NAD83
 Vertical datum: NAVD83

FOR TENTATIVE TRACT MAP APPLICATION
 SITE PLAN FOR LUXE LOCKER - CLOSE VIEW
 SITUATED IN THE NORTHEAST 1/4 OF SECTION 23
 TOWNSHIP 21 NORTH, RANGE 20 EAST, M.D.M.
 RENO WASHOE COUNTY NEVADA

SHEET
 1
 OF
 1

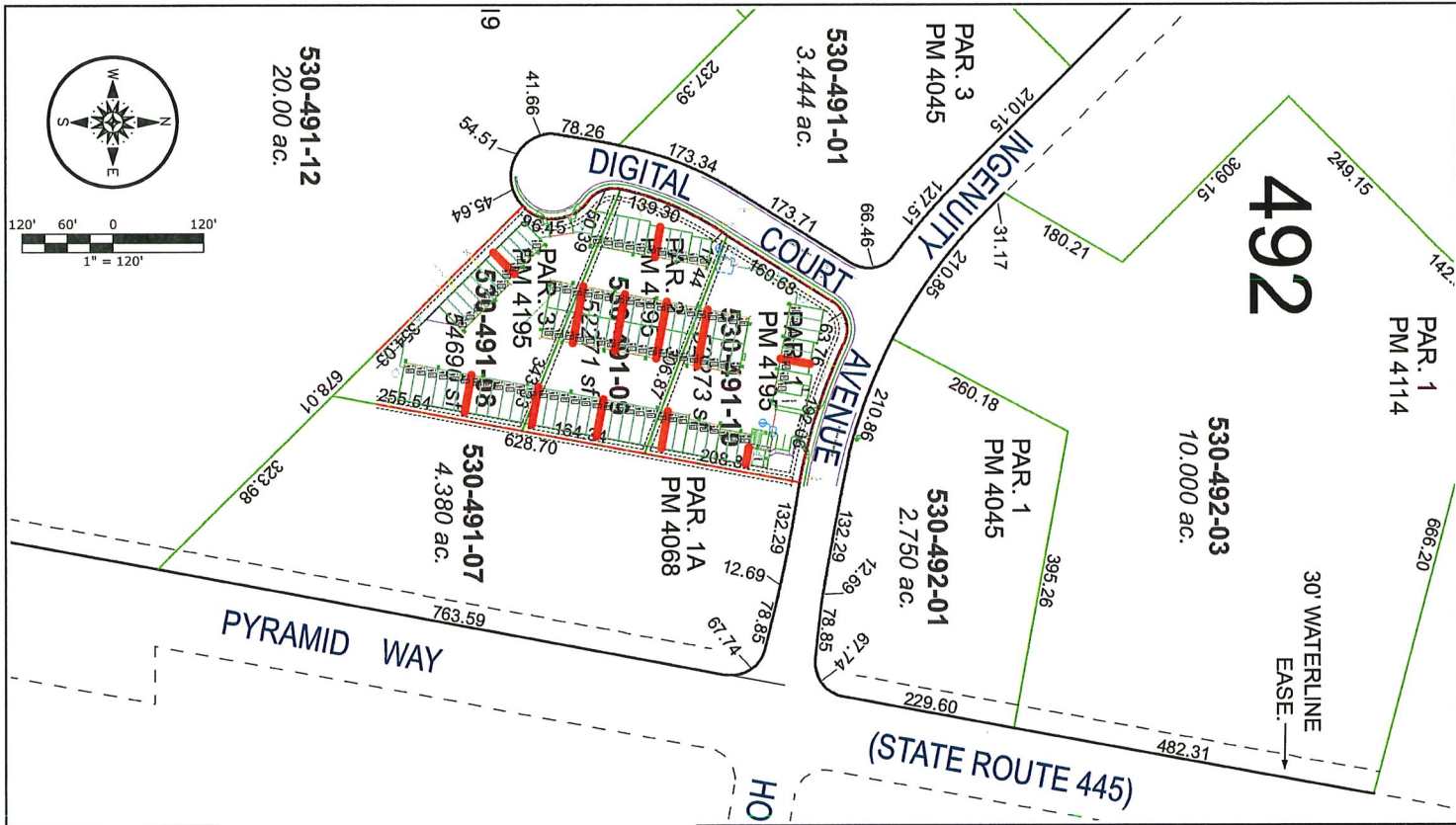

US GEOMATICS
 P.O. Box 3299
 648 Lander Street
 Reno, NV 89505
 P. 775.786.5111
 www.usgeomatix.com
 info@usgeomatix.com

| | | | |
|--------------|------------|-----------------|-----------|
| Project No: | 184-03-19 | Horiz. scale: | 1" = 120' |
| Date: | 10-15-2014 | Vertical scale: | |
| Drawn by: | DJL | Project: | |
| Designed by: | DJL | Horiz. datum: | NAD83 |
| Checked by: | AV | Vertical datum: | NAVD83 |

FOR TENTATIVE TRACT MAP APPLICATION
 SITE PLAN FOR LUXE LOCKER - VICINITY VIEW
 SITUATED IN THE NORTHEAST 1/4 OF SECTION 23
 TOWNSHIP 21 NORTH, RANGE 20 EAST, M.D.M.
 RENO WASHOE COUNTY NEVADA

SHEET
 1
 OF
 1

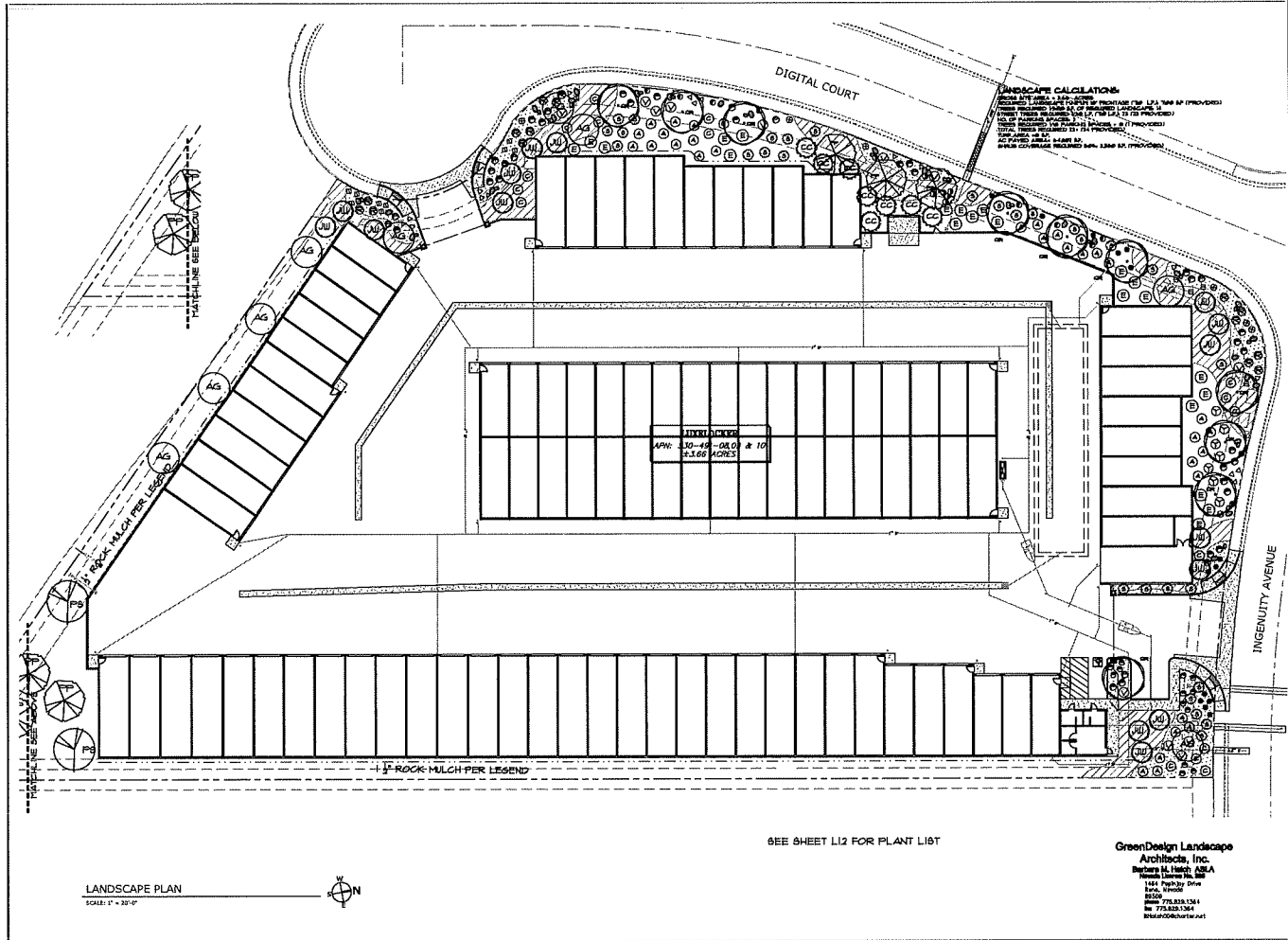

LANDSCAPE CALCULATION:
 TOTAL AREA: 12,500 SQ. FT. (PROVIDED)
 TOTAL PLANTING AREA: 12,500 SQ. FT. (PROVIDED)
 TOTAL PLANTING QUANTITY: 12,500 (PROVIDED)
 TOTAL PLANTING COST: \$12,500 (PROVIDED)
 TOTAL PLANTING MATERIALS: 12,500 (PROVIDED)
 TOTAL PLANTING LABOR: 12,500 (PROVIDED)
 TOTAL PLANTING TOTAL: 12,500 (PROVIDED)

As shown herein are the property of Tectonics Design Group and are not to be reproduced or used in any manner without the written permission of Tectonics Design Group.

| | |
|--------------|---|
| DATE: | 02/11/2011 |
| SCALE: | AS SHOWN |
| PROJECT: | 11485 Digital Court, Spanish Springs, Nevada |
| CLIENT: | Consolidated Construction Co Inc. |
| LOCATION: | APPROX. W. 11485 Digital Court, Spanish Springs, Nevada |
| DESIGNER: | GreenDesign Landscape Architects, Inc. |
| PROJECT NO.: | 11485 Digital Court |
| SHEET NO.: | L1.1 |

TECTONICS DESIGN GROUP
 11485 Digital Court, Spanish Springs, Nevada
 Consolidated Construction Co Inc.
 APPROX. W. 11485 Digital Court, Spanish Springs, Nevada

GreenDesign Landscape Architects, Inc.
 Barbara H. Hsieh AIA
 11485 Digital Court, Spanish Springs, Nevada
 702.733.1244
 702.733.1244
 info@greenlandscape.com

LUXLOCKER
 11485 Digital Court, Spanish Springs, Nevada
 Consolidated Construction Co Inc.
 APPROX. W. 11485 Digital Court, Spanish Springs, Nevada

LANDSCAPE PLAN
 L1.1

PLANT LIST

| KEY NO. | BOTANICAL NAME | COMMON NAME | SIZE | REMARKS |
|------------------------|-------------------------|----------------------|-------------------------|---------------------|
| DECIDUOUS TREES | | | | |
| DR | Q. LAEVOGARRULA | BUR OAK | 24" BOK OR D x 8" B | 2" PIN CAL. HATCHED |
| AG | A. ACER GINALE PLATE | AMERICAN LIME | 1 1/4" PIN CAL. HATCHED | |
| EVERGREEN TREES | | | | |
| PH | P. PARVIFLORA | ADONIS PINE | 8" GAL. OR B x 8" B | 4" PIN HEIGHT |
| PS | P. PARVIFLORA | ADONIS PINE | 8" GAL. OR B x 8" B | 4" PIN HEIGHT |
| JR | J. REPENS | ARIZONA CEDAR | 8" GAL. OR B x 8" B | 4" PIN HEIGHT |
| SHRUBS | | | | |
| 1 | PRUNUS BISSERTII | BIRD CHERRY | 8" GAL. | 24" PIN HEIGHT |
| A | ACER INCANUM | SCARLET OAK | 8" GAL. | 24" PIN HEIGHT |
| C | COTYNEA P. MOOREI | MOOREI BURNING BUSH | 8" GAL. | 18" PIN HEIGHT |
| 3 | PRUNUS PANDO | DELICIOUS PINE | 8" GAL. | 18" PIN HEIGHT |
| R | ROSEMOYNE | ROSEMOYNE | 8" GAL. | 18" PIN HEIGHT |
| Y | YUCCA | YUCCA | 1 GAL. | 18" PIN HEIGHT |
| CG | COTYNEA C. NOTAL PURPLE | NOTAL PURPLE | 8" GAL. | 24" PIN HEIGHT |
| E | ERIGONIA TARTARICA | TARTARIC HONEYBUCKLE | 8" GAL. | 24" PIN HEIGHT |
| FERREALS | | | | |
| D | DIAPYCNON | YARROW | 1 GAL. | 18" PIN HEIGHT |
| H | HESPERIS | CALIF. PURSUA | 1 GAL. | 18" PIN HEIGHT |
| G | GALANUS | MAJID N. BOPPER | 1 GAL. | 18" PIN HEIGHT |
| V | VIBURNUM | REISHAN BUSH | 1 GAL. | 18" PIN HEIGHT |
| GRASSES | | | | |
| S | S. SPERMATOPHYTES | PLAIDEN GRASS | 1 GAL. | 18" PIN HEIGHT |
| D | D. CALYPTROGLOBA | FEATHERGRASS | 1 GAL. | 18" PIN HEIGHT |

LANDSCAPE LEGEND

- ROCK MULCH**
ALL PLANTERS NOT DESIGNATED FOR ROCK MULCH SHALL BE COVERED TO 2" MIN. DEPTH OF 1/4" FRACTURED PLATE COVER HATCHED PERMANENTLY WHITE. PLACE 2" LANDSCAPE FABRIC OVER ALL PLANTERS. PLACE 2" SAND BEDDED ROCK MULCH IN ALL PLANTERS. REFER TO DETAIL SHEET L-13.
- DECOMPOSED GRANITE**
ALL PLANTERS AS SHOWN. 2" MIN. DEPTH OF DECOMPOSED GRANITE. PLACE OVER SAND BEDDED COVER. PLACE SAND/GRIT NET AND COMPACT.
- ROCK MULCH WITH FABRIC**
2" MIN. DEPTH OF 1/4" FRACTURED PLATE COVER HATCHED PERMANENTLY WHITE. PLACE 2" LANDSCAPE FABRIC OVER ALL PLANTERS. PLACE 2" SAND BEDDED ROCK MULCH IN ALL PLANTERS. REFER TO DETAIL SHEET L-13.
- 2" DIA. SOLID STONE**
FRAMES BEING COLOR WITH FELCH. REFER TO DETAIL SHEET L-13.

NOTE:
IF TREE OR LARGER PROVIDED WHEN CHAINS OUTSIDE OF TREE WERE SET LINES EQUAL DISTANCE AROUND TREE ANCHOR 8" FROM CENTER OF TREE SURVEY PRE-MANUFACTURED GUY SYSTEM OR PLAN OF FABRICATED SYSTEM FOR APPROVAL PRIOR TO INSTALL. LINE TO BE 1/4" GALVANIZED CABLE WITH TURN BUCKLE FOR TIGHTENING. USE CLIPPS TO SECURE STRAPS PER 1/4" OF ANCHOR POINT AT ALL POINTS. SECURE ANCHOR POINTS WITH TURN OR LOCK AS SHOWN.

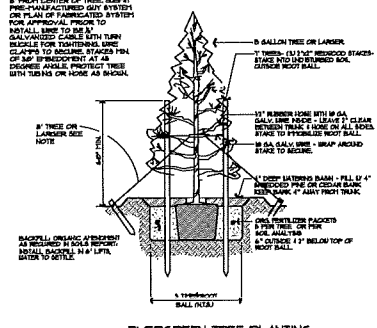

GENERAL LANDSCAPE NOTES:

THE CONTRACTOR SHALL COORDINATE ALL WORK WITH OTHER TRADES (ELECTRICAL, PLUMBING, MECHANICAL, ETC.)
ALL SOIL SHALL BE LOOSEMED TO A DEPTH OF 6" IN ALL PLANTER AREAS PRIOR TO PLANTING. BARE CUT ALL ROCK AND DEBRIS DEEPER THAN 1/4" DIAMETER.
ALL GRASSES SHALL BE APPROVED BY THE OWNER'S REPRESENTATIVE AFTER SOIL LOGS, LOGS, IRRIGATION TUBES AND FINAL GRADING IS COMPLETE PRIOR TO PLANTING.
SOIL IN THE PLANT BEDDING SHALL BE AMENDED PER A SOIL ANALYSIS REPORT AND RECOMMENDATIONS PREPARED BY AN AGRICULTURAL, METEOROLOGICAL, SOIL SCIENTIST. THE LANDSCAPE CONTRACTOR SHALL TAKE A MIN. OF 8 SAMPLES, A MIN. OF 200 FROM EACH PLANTER AREA AFTER ALL SITE GRADING HAS OCCURRED AND PLANTERS ARE BROUGHT TO GRADE. IF REQUIRED PER CIVIL ENGINEER THE CONTRACTOR SHALL SUBMIT ONE COPIED SAMPLE OF THE SOIL FOR ANALYSIS AND RECOMMENDATIONS. A COPY OF THE SOIL ANALYSIS REPORT SHALL BE SUBMITTED TO THE OWNER'S REPRESENTATIVE FOR HIS REVIEW PRIOR TO THE PLANTING. A COPY OF THE SOIL ANALYSIS REPORT SHALL BE SUBMITTED TO THE OWNER'S REPRESENTATIVE FOR HIS REVIEW PRIOR TO THE PLANTING. A COPY OF THE SOIL ANALYSIS REPORT SHALL BE SUBMITTED TO THE OWNER'S REPRESENTATIVE FOR HIS REVIEW PRIOR TO THE PLANTING.

IT IS THE RESPONSIBILITY OF THE CONTRACTOR TO LOCATE AND PROVIDE PLANT MATERIAL AS SPECIFIED ON THIS PLAN. THE CONTRACTOR SHALL HAVE A RECEIPT TO PROVIDE SUBSTITUTIONS FOR THE SPECIFIED PLANT MATERIAL UNDER THE FOLLOWING CONDITIONS:
A. ANY SUBSTITUTION PROPOSED SHALL BE SUBMITTED TO THE OWNER'S REPRESENTATIVE WITH TWO SETS OF THE GUARANTEE CONTRACT. SUBSTITUTIONS MUST BE EQUIVALENT DRIVING AND FUNCTIONAL TO THE ORIGINAL PLANT MATERIAL AS DETERMINED BY THE OWNER'S REPRESENTATIVE. ANY CHANGES MUST HAVE THE APPROVAL OF THE OWNER'S REPRESENTATIVE PRIOR TO INSTALLING PLANT MATERIAL.
B. THE RECEIPT MUST BE ACCOMPANIED BY AT LEAST THREE NOTICES FROM PLANT SUPPLIER THAT THE PLANT MATERIAL SPECIFIED IS NOT AVAILABLE PRIOR TO THE CONSTRUCTION PHASE.
C. ALL PLANTS NOT FURNISHED OR EXCEEDING REQUIREMENTS AND RECOMMENDATIONS OF JUNE 2001 (PERMANENT GUARANTEE) MUST BE REPLACED. THE CONTRACTOR SHALL REMOVE AND REPLACE PLANT MATERIAL IN ALL PLANTERS. THE CONTRACTOR SHALL REMOVE AND REPLACE PLANT MATERIAL IN ALL PLANTERS. THE CONTRACTOR SHALL REMOVE AND REPLACE PLANT MATERIAL IN ALL PLANTERS. THE CONTRACTOR SHALL REMOVE AND REPLACE PLANT MATERIAL IN ALL PLANTERS.

THE CONTRACTOR SHALL GUARANTEE ALL PLANT MATERIALS FOR ONE FULL YEAR UPON FINAL ACCEPTANCE OF THE PROJECT. THE CONTRACTOR SHALL MAINTAIN THE SITE INCLUDING BATTER SCHEDULING FOR THE ONE YEAR GUARANTEE PERIOD. ANY PLANTS REPLACED UNDER THE GUARANTEE SHALL BE GUARANTEED FOR ONE FULL YEAR FROM THE DATE OF REPLACEMENT.
THE LANDSCAPE CONTRACTOR SHALL INSURE POSITIVE DRAINAGE IN ALL PLANTER AREAS PER CIVIL ENGINEER'S GRADING PLAN AFTER LANDSCAPE IMPROVEMENTS ARE COMPLETE.
REMOVE ALL WEEDS AND DEBRIS IN AND AROUND NEARLY INSTALLED PLANT MATERIAL. A PRE-PERMANENT HERBICIDE SHALL BE APPLIED AROUND PLANTERS PRIOR TO INSTALLATION OF MULCHES.

GreenDesign Landscape Architects, Inc.
Barbara M. Harkis, AIA
1661 Highway 100
Suite 100
Bismarck, ND 58102
701.733.1364
701.733.1364
Bismarck@harkis.com

All drawings herein are the property of Tectonics Design Group and shall not be reproduced or used in any manner without the written authorization of Tectonics Design Group.

DATE: 10/12/19
SUBMITAL: PERMIT SET

LANDSCAPE PLAN

TECTONICS DESIGN GROUP
11455 Durbin Court, Durbin, South Dakota, 57013
P.O. Box 100, Durbin, South Dakota, 57013
Tel: 605.238.2222
Fax: 605.238.2222

LUXELOCKER
11455 Durbin Court, Durbin, South Dakota, 57013
Consolidated Construction Co. Inc.
Aurora, WI

DATE: 10/12/19
SUBMITAL: PERMIT SET

LANDSCAPE PLAN

L1.2

MAINTENANCE
 THE IRRIGATION SHALL BE MAINTAINED TO ENSURE
 SUFFICIENT AND TIMELY WATERING NECESSARY FOR
 THE SURVIVAL OF ALL PLANT MATERIAL. A COPY
 OF THE APPROVED IRRIGATION PLAN WITH ANY
 ANNUAL CONDITIONS SHALL BE KEPT ON THE
 PROJECT SITE FOR INSPECTION. THE SYSTEM SHALL
 BE CHECKED YEARLY FOR CONTINUED OPERATION
 WITH THE ORIGINAL PLAN AND COMPONENTS
 ADJUSTED AND OR REPLACED AS PROVIDED FOR
 EFFICIENT OPERATION OF THE SYSTEM TO PROVIDE
 SUFFICIENT WATER TO ENSURE THE HEALTH OF THE
 PLANT MATERIAL.

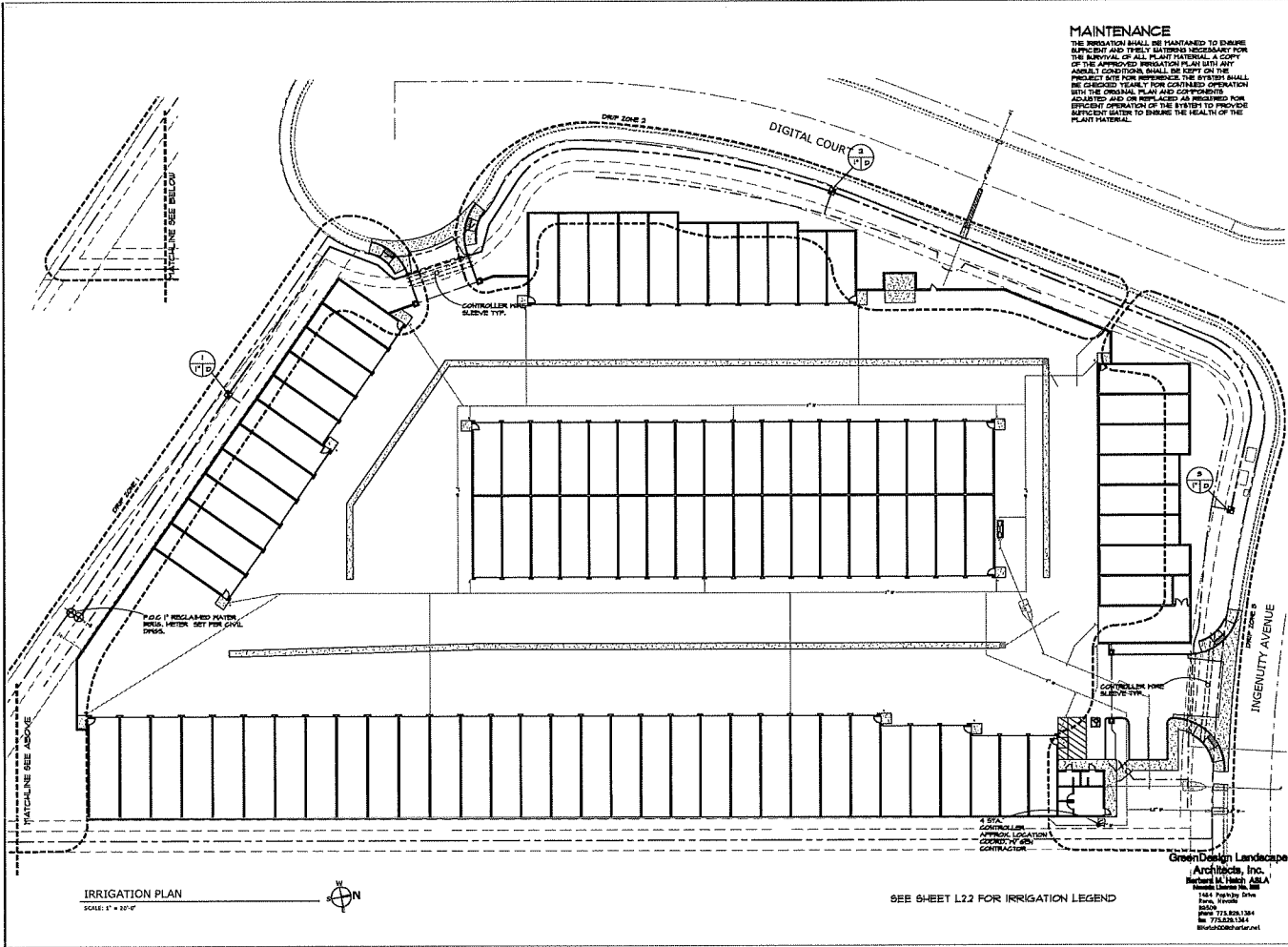

IRRIGATION PLAN
 SCALE: 1" = 20'-0"



SEE SHEET L22 FOR IRRIGATION LEGEND

Green Design Landscape
 Architects, Inc.
 Richard M. Hersh, AIA
 144 Parkway Drive
 Park, Nevada
 89020
 PH: 775.824.1364
 FX: 775.824.1344
 WWW.GDLDESIGN.COM

All drawings herein are the property of Tectonics Design Group and are not to be reproduced or used in any capacity without the written authorization of Tectonics Design Group.

CLIENT: TBD
 CHECKED/DATE: 04/26/2019
 DESIGNED BY: HANNAH W. HANCOCK AIA



**TECTONICS
 DESIGN GROUP**
 225 Nevada Blvd., 20th Floor, Nevada, Nevada 89501
 PH: 775.824.1364
 FX: 775.824.1344
 WWW.TECTONICSGROUP.COM

LUXELOCKER
 11455 Digital Court, Spanish Springs, Nevada
 Consolidated Construction Co Inc.
 Appleton, WI

DATE: 02/22/19
 SUBMITTAL: PERMIT SET

IRRIGATION PLAN

L2.1

Property Owner Affidavit

Applicant Name: Spanish Springs Storage Partners LLC

The receipt of this application at the time of submittal does not guarantee the application complies with all requirements of the Washoe County Development Code, the Washoe County Master Plan or the applicable area plan, the applicable regulatory zoning, or that the application is deemed complete and will be processed.

STATE OF ^{Arizona} NEVADA)
COUNTY OF ^{Mohave} WASHOE)

I, Adam C. Pakes
(please print name)

being duly sworn, depose and say that I am the owner* of the property or properties involved in this application as listed below and that the foregoing statements and answers herein contained and the information herewith submitted are in all respects complete, true, and correct to the best of my knowledge and belief. I understand that no assurance or guarantee can be given by members of Planning and Building.

(A separate Affidavit must be provided by each property owner named in the title report.)

Assessor Parcel Number(s): 530-491-08, 530-491-09, 530-491-10

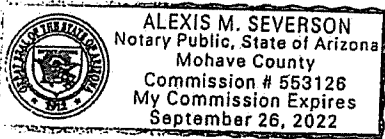

Printed Name Adam C. Pakes

Signed [Signature]

Address 3595 South Town Center Dr. 107

Las Vegas, NV 89135

Subscribed and sworn to before me this 11 day of October, 2019.

(Notary Stamp)

Alexis M. Severson
Notary Public in and for said county and state

My commission expires: Sept. 26, 2022

*Owner refers to the following: (Please mark appropriate box.)

- Owner
- Corporate Officer/Partner (Provide copy of record document indicating authority to sign.)
- Power of Attorney (Provide copy of Power of Attorney.)
- Owner Agent (Provide notarized letter from property owner giving legal authority to agent.)
- Property Agent (Provide copy of record document indicating authority to sign.)
- Letter from Government Agency with Stewardship

ENTITY INFORMATION**ENTITY INFORMATION****Entity Name:**

SPANISH SPRINGS STORAGE PARTNERS LLC

Entity Number:

E0069472019-1

Entity Type:

Domestic Limited-Liability Company (86)

Entity Status:

Active

Formation Date:

02/14/2019

NV Business ID:

NV20191123649

Termination Date:

Perpetual

Annual Report Due Date:

2/29/2020

Series LLC:**Restricted LLC:**

REGISTERED AGENT INFORMATION**Name of Individual or Legal Entity:**

LAW OFFICE OF MICHAEL R. MCNERNY, CHTD

Status:

Active

CRA Agent Entity Type:**Registered Agent Type:**

Commercial Registered Agent

NV Business ID:

NV20141676975

Office or Position:**Jurisdiction:****Street Address:**

7995 WEST SAHARA AVENUE SUITE 101, LAS VEGAS, NV, 89117, USA

Email Address:

MMCNERNY@MCNERNYLAW.COM

Mailing Address:**Individual with Authority to Act:****Contact Phone Number:****Fictitious Website or Domain Name:****PRINCIPAL OFFICE ADDRESS**

Address:

Mailing Address:

OFFICER INFORMATION

VIEW HISTORICAL DATA

| Title | Name | Address | Last Updated | Status |
|---------|-------------------------|---|--------------|--------|
| Manager | SUMMERLIN DESERT LLC | 1845 MCCULLOCH BLVD. STE. A6, LAKE HAVASU CITY, AZ, 86403, USA | 02/14/2019 | Active |

Page 1 of 1, records 1 to 1 of 1

[Filing History](#)

[Name History](#)

[Mergers/Conversions](#)

[Return to Search](#)

[Return to Results](#)

**UNANIMOUS WRITTEN CONSENT
OF THE MEMBERS
OF
SUMMERLIN DESERT, LLC**

The undersigned, being authorized to execute this resolution on behalf of Summerlin Asset Management LLC, and Desert Land Group LLC, who are each and all of the Members of Summerlin Desert LLC, a member-managed Nevada limited liability company (the "Company"), hereby unanimously resolve and consent to the adoption of, and adopt, the following resolution, effective as of *August 2*, 2016.

WHEREAS, on or about July 8th, 2016, the Members entered into an Operating Agreement controlling the governance and business affairs of the Company;

WHEREAS, under and in accordance with the Operating Agreement, the Members shall manage the Company by unanimous vote or written consent;

WHEREAS, Section 5.1 of the Operating Agreement provides that "the Managing Members may "appoint or discharge an agent or agents to conduct particular affairs of the business"; and

WHEREAS, the Managers have determined that it is necessary and expedient to appoint an authorized signatory for the Company, to execute all instruments, agreements, and other documents for and in the name of the Company;

NOW, THEREFORE, BE IT UNANIMOUSLY RESOLVED THAT the Adam C. Pakes is hereby authorized to execute by his signature all papers, instruments, contracts, letters, forms, deeds or other documents in the name of the Company in connection with any and all of its business affairs. The acts done and documents so executed shall be binding on the Company, unless and until this resolution is revoked, and notice of such revocation is provided to the recipient hereof.

Specimen Signature of Authorized Signatory: _____

RESOLVED FURTHER THAT, a copy of the above resolution duly certified as true by the authorized signatory of the Company may be furnished to such parties as may be required from time to time in connection with the above matter.

WHEREFORE, the undersigned affix their authorized signatures below

DESERT LAND GROUP, LLC
An Arizona limited liability company

By: _____

Name: Mikhail GORDEN

Title: Manager

Date: 8/2/16

SUMMERLIN ASSET MANAGEMENT, LLC
A Nevada limited liability company

By: _____

Name: Adam C. Pakes

Title: Manager

Date: 8/2/16

Washoe County Treasurer
 Tammi Davis

Account Detail

[Back to Account Detail](#)

[Change of Address](#)

[Print this Page](#)

CollectionCart

| Collection Cart | Items | Total | Checkout | View |
|-----------------|-------|--------|--------------------------|----------------------|
| | 0 | \$0.00 | | |

Pay Online

No payment due for this account.

Washoe County Parcel Information

| Parcel ID | Status | Last Update |
|-----------|--------|-----------------------|
| 53049108 | Active | 10/16/2019 2:07:32 AM |

Current Owner:
 SPANISH SPRINGS STORAGE PARTNERS LLC
 C/O MICHAEL R MCNERNY
 1845 MCCULLOCH BLVD N STE A6
 LAKE HAVASU CITY, AZ 86403

SITUS:
 11435 DIGITAL CT

Taxing District
 4000

Geo CD:

Legal Description

Lot 3 SubdivisionName _UNSPECIFIED Township 21 Range 20

Tax Bill (Click on desired tax year for due dates and further details)

| Tax Year | Net Tax | Total Paid | Penalty/Fees | Interest | Balance Due |
|----------------------|----------|------------|--------------|----------|-------------|
| 2019 | \$955.22 | \$964.78 | \$0.00 | \$0.00 | \$0.00 |
| 2018 | \$911.49 | \$911.49 | \$0.00 | \$0.00 | \$0.00 |
| 2017 | \$874.91 | \$874.91 | \$0.00 | \$0.00 | \$0.00 |
| 2016 | \$874.66 | \$874.66 | \$0.00 | \$0.00 | \$0.00 |
| 2015 | \$874.94 | \$874.94 | \$0.00 | \$0.00 | \$0.00 |
| Total | | | | | \$0.00 |

Disclaimer

- **ALERTS:** If your real property taxes are delinquent, the search results displayed may not reflect the correct amount owing. Please contact our office for the current amount due.
- For your convenience, online payment is available on this site. E-check payments are accepted without a fee. However, a service fee does apply for online credit card payments. See Payment Information for details.

Pay By Check

Please make checks payable to:
WASHOE COUNTY TREASURER

Mailing Address:
 P.O. Box 30039
 Reno, NV 89520-3039

Overnight Address:
 1001 E. Ninth St., Ste D140
 Reno, NV 89512-2845

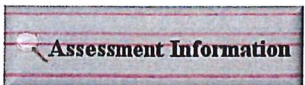
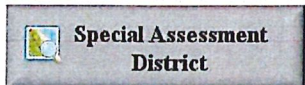

Washoe County Treasurer
 Tammi Davis

Account Detail

[Back to Account Detail](#)

[Change of Address](#)

[Print this Page](#)

CollectionCart

| Collection Cart | Items | Total | Checkout | View |
|-----------------|-------|--------|--------------------------|----------------------|
| | 0 | \$0.00 | | |

Pay Online

No payment due for this account.

Washoe County Parcel Information

| Parcel ID | Status | Last Update |
|-----------|--------|-----------------------|
| 53049109 | Active | 10/16/2019 2:07:32 AM |

Current Owner:
 SPANISH SPRINGS STORAGE PARTNERS LLC
 C/O MICHAEL R MCNERNY
 1845 MCCULLOCH BLVD N STE A6
 LAKE HAVASU CITY, AZ 86403

SITUS:
 11445 DIGITAL CT

Taxing District
 4000

Geo CD:

Legal Description

SubdivisionName _UNSPECIFIED Lot 2 Township 21 Range 20

Tax Bill (Click on desired tax year for due dates and further details)

| Tax Year | Net Tax | Total Paid | Penalty/Fees | Interest | Balance Due |
|----------------------|----------|------------|--------------|----------|---------------|
| 2019 | \$913.25 | \$922.39 | \$0.00 | \$0.00 | \$0.00 |
| 2018 | \$871.44 | \$871.44 | \$0.00 | \$0.00 | \$0.00 |
| 2017 | \$836.47 | \$836.47 | \$0.00 | \$0.00 | \$0.00 |
| 2016 | \$836.26 | \$836.26 | \$0.00 | \$0.00 | \$0.00 |
| 2015 | \$836.56 | \$836.56 | \$0.00 | \$0.00 | \$0.00 |
| Total | | | | | \$0.00 |

Disclaimer

- **ALERTS:** If your real property taxes are delinquent, the search results displayed may not reflect the correct amount owing. Please contact our office for the current amount due.
- For your convenience, online payment is available on this site. E-check payments are accepted without a fee. However, a service fee does apply for online credit card payments. See Payment Information for details.

Pay By Check

Please make checks payable to:
 WASHOE COUNTY TREASURER

Mailing Address:
 P.O. Box 30039
 Reno, NV 89520-3039

Overnight Address:
 1001 E. Ninth St., Ste D140
 Reno, NV 89512-2845

 **Payment Information**

 **Special Assessment District**

 **Installment Date Information**

 **Assessment Information**

Washoe County Treasurer
 P.O. Box 30039, Reno, NV 89520-3039
 ph: (775) 328-2510 fax: (775) 328-2500
 Email: tax@washoecounty.us

Washoe County Treasurer
 Tammi Davis

Account Detail

[Back to Account Detail](#)

[Change of Address](#)

[Print this Page](#)

CollectionCart

| Collection Cart | Items | Total |
|-----------------|-------|--------|
| | 0 | \$0.00 |

[Checkout](#) [View](#)

Pay Online

No payment due for this account.

Washoe County Parcel Information

| Parcel ID | Status | Last Update |
|-----------|--------|-----------------------|
| 53049110 | Active | 10/16/2019 2:07:32 AM |

Current Owner:
 SPANISH SPRINGS STORAGE PARTNERS LLC
 C/O MICHAEL R MCNERNY
 1845 MCCULLOCH BLVD N A6
 LAKE HAVASU CITY, AZ 86403

SITUS:
 11455 DIGITAL CT

Taxing District
 4000

Geo CD:

Legal Description

SubdivisionName _UNSPECIFIED Lot 1 Township 21 Range 20

Tax Bill (Click on desired tax year for due dates and further details)

| Tax Year | Net Tax | Total Paid | Penalty/Fees | Interest | Balance Due |
|----------------------|----------|------------|--------------|----------|---------------|
| 2019 | \$913.29 | \$922.43 | \$0.00 | \$0.00 | \$0.00 |
| 2018 | \$871.48 | \$871.48 | \$0.00 | \$0.00 | \$0.00 |
| 2017 | \$836.51 | \$836.51 | \$0.00 | \$0.00 | \$0.00 |
| 2016 | \$836.29 | \$836.29 | \$0.00 | \$0.00 | \$0.00 |
| 2015 | \$836.58 | \$836.58 | \$0.00 | \$0.00 | \$0.00 |
| Total | | | | | \$0.00 |

Disclaimer

- **ALERTS:** If your real property taxes are delinquent, the search results displayed may not reflect the correct amount owing. Please contact our office for the current amount due.
- For your convenience, online payment is available on this site. E-check payments are accepted without a fee. However, a service fee does apply for online credit card payments. See Payment Information for details.

Pay By Check

Please make checks payable to:
 WASHOE COUNTY TREASURER

Mailing Address:
 P.O. Box 30039
 Reno, NV 89520-3039

Overnight Address:
 1001 E. Ninth St., Ste D140
 Reno, NV 89512-2845

 **Payment Information**

 **Special Assessment District**

 **Installment Date Information**

 **Assessment Information**

**UNANIMOUS WRITTEN CONSENT
OF THE MEMBERS
OF
SUMMERLIN DESERT, LLC**

The undersigned, being authorized to execute this resolution on behalf of Summerlin Asset Management LLC, and Desert Land Group LLC, who are each and all of the Members of Summerlin Desert LLC, a member-managed Nevada limited liability company (the "Company"), hereby unanimously resolve and consent to the adoption of, and adopt, the following resolution, effective as of August 2, 2016.

WHEREAS, on or about July 8th, 2016, the Members entered into an Operating Agreement controlling the governance and business affairs of the Company;

WHEREAS, under and in accordance with the Operating Agreement, the Members shall manage the Company by unanimous vote or written consent;

WHEREAS, Section 5.1 of the Operating Agreement provides that "the Managing Members may "appoint or discharge an agent or agents to conduct particular affairs of the business"; and

WHEREAS, the Managers have determined that it is necessary and expedient to appoint an authorized signatory for the Company, to execute all instruments, agreements, and other documents for and in the name of the Company;

NOW, THEREFORE, BE IT UNANIMOUSLY RESOLVED THAT the Adam C. Pakes is hereby authorized to execute by his signature all papers, instruments, contracts, letters, forms, deeds or other documents in the name of the Company in connection with any and all of its business affairs. The acts done and documents so executed shall be binding on the Company, unless and until this resolution is revoked, and notice of such revocation is provided to the recipient hereof.

Specimen Signature of Authorized Signatory: _____

RESOLVED FURTHER THAT, a copy of the above resolution duly certified as true by the authorized signatory of the Company may be furnished to such parties as may be required from time to time in connection with the above matter.

WHEREFORE, the undersigned affix their authorized signatures below

DESERT LAND GROUP, LLC
An Arizona limited liability company

By: _____

Name: MICHAEL GORDEN

Title: Manager

Date: 8/2/16

SUMMERLIN ASSET MANAGEMENT, LLC
A Nevada limited liability company

By: _____

Name: Adam C. Pakes

Title: Manager

Date: 8/2/16

OWNER'S CERTIFICATE:

THIS IS TO CERTIFY THAT THE UNDERSIGNED, SPANISH SPRINGS STORAGE PARTNERS LLC, IS THE OWNER OF THE TRACT OF LAND REPRESENTED ON THIS PLAT AND HAS CONSENTED TO THE PREPARATION AND RECORDATION OF THIS PLAT, AND THAT THE SAME IS EXECUTED IN COMPLIANCE WITH AND SUBJECT TO THE PROVISIONS OF N.R.S. CHAPTER 278.

SPANISH SPRINGS STORAGE PARTNERS LLC

DATE

NAME: _____

TITLE: _____

NOTARY PUBLIC ACKNOWLEDGMENT:

STATE OF NEVADA
COUNTY OF WASHOE S.S.

ON THIS _____ DAY OF _____, 2019, _____ OF SPANISH SPRINGS STORAGE PARTNERS LLC, DID PERSONALLY APPEAR BEFORE ME TO PERSONALLY ACKNOWLEDGE THIS INSTRUMENT.

NOTARY PUBLIC

MY COMMISSION EXPIRES _____

TITLE COMPANY CERTIFICATE:

THE UNDERSIGNED HEREBY CERTIFIES THAT THIS PLAT HAS BEEN EXAMINED AND THAT SPANISH SPRINGS STORAGE PARTNERS LLC, ARE THE ONLY OWNERS OF RECORD OF SAID LAND; THAT NO ONE HOLDS OF RECORD A SECURITY INTEREST IN SAID LAND; THAT THERE ARE NO LIENS OF RECORD AGAINST SAID LAND FOR DELINQUENT STATE, COUNTY, MUNICIPAL, FEDERAL, OR LOCAL TAXES COLLECTED AS TAXES OR SPECIAL ASSESSMENTS.

FIRST AMERICAN TITLE INSURANCE COMPANY

DATE

NAME: _____

TITLE: _____

TAX CERTIFICATE:

THE UNDERSIGNED HEREBY CERTIFIES THAT ALL PROPERTY TAXES ON THE LAND SHOWN HEREON FOR THE FISCAL YEAR HAVE BEEN PAID AND THAT THE FULL AMOUNT OF ANY DEFERRED PROPERTY TAXES FOR THE CONVERSION OF THE PROPERTY FROM AGRICULTURAL USE HAS BEEN PAID PURSUANT TO N.R.S. 361A.265.
APN: 530-491-08, 530-491-09, 530-491-10

WASHOE COUNTY TREASURY DEPT. _____
DATE

NAME: _____

TITLE: _____

DISTRICT HEALTH DEPARTMENT CERTIFICATE:

THIS FINAL MAP IS APPROVED BY THE WASHOE COUNTY DISTRICT BOARD OF HEALTH. THIS APPROVAL CONCERNS SEWAGE DISPOSAL, WATER POLLUTION, WATER QUALITY, AND WATER SUPPLY FACILITIES AND IS PREDICATED UPON PLANS FOR A PUBLIC WATER SUPPLY AND A COMMUNITY SYSTEM FOR DISPOSAL OF SEWAGE.

DISTRICT BOARD OF HEALTH _____
DATE

NAME: _____

TITLE: _____

DIVISION OF WATER RESOURCES CERTIFICATE:

THIS PLAT IS APPROVED BY THE STATE OF NEVADA DIVISION OF WATER RESOURCES OF THE DEPARTMENT OF CONSERVATION AND NATURAL RESOURCES CONCERNING WATER QUANTITY, SUBJECT TO REVIEW OF APPROVAL ON FILE IN THIS OFFICE.

DIVISION OF WATER RESOURCES _____
DATE

NAME: _____

TITLE: _____



VICINITY MAP
(NOT TO SCALE)

UTILITY COMPANIES CERTIFICATE:

THE UTILITY EASEMENTS SHOWN HEREON AND THE EASEMENT RELINQUISHMENTS SHOWN ON THIS PLAT HAVE BEEN CHECKED, ACCEPTED AND APPROVED BY THE UNDERSIGNED PUBLIC UTILITY COMPANIES. THE UNDERSIGNED FURTHER ACKNOWLEDGE AND AGREE TO RELINQUISH THE EASEMENTS NOTED AS SUCH HEREIN.

CHARTER COMMUNICATIONS _____
DATE

NAME: _____

TITLE: _____

STATE OF NEVADA
COUNTY OF WASHOE S.S.

ON THIS _____ DAY OF _____, 2019, _____ OF CHARTER COMMUNICATIONS, DID PERSONALLY APPEAR BEFORE ME TO PERSONALLY ACKNOWLEDGE THIS INSTRUMENT.

NOTARY PUBLIC

MY COMMISSION EXPIRES _____

NEVADA BELL TELEPHONE COMPANY
D/B/A AT&T NEVADA _____
DATE

NAME: _____

TITLE: _____

STATE OF NEVADA
COUNTY OF WASHOE S.S.

ON THIS _____ DAY OF _____, 2019, _____ OF AT&T NEVADA, DID PERSONALLY APPEAR BEFORE ME TO PERSONALLY ACKNOWLEDGE THIS INSTRUMENT.

NOTARY PUBLIC

MY COMMISSION EXPIRES _____

SIERRA PACIFIC POWER COMPANY
D/B/A NV ENERGY _____
DATE

NAME: _____

TITLE: _____

STATE OF NEVADA
COUNTY OF WASHOE S.S.

ON THIS _____ DAY OF _____, 2019, _____ OF AT&T NEVADA, DID PERSONALLY APPEAR BEFORE ME TO PERSONALLY ACKNOWLEDGE THIS INSTRUMENT.

NOTARY PUBLIC

MY COMMISSION EXPIRES _____

TRUCKEE MEADOWS WATER AUTHORITY _____
DATE

NAME: _____

TITLE: _____

STATE OF NEVADA
COUNTY OF WASHOE S.S.

ON THIS _____ DAY OF _____, 2019, _____ OF TRUCKEE MEADOWS WATER AUTHORITY, DID PERSONALLY APPEAR BEFORE ME TO PERSONALLY ACKNOWLEDGE THIS INSTRUMENT.

NOTARY PUBLIC

MY COMMISSION EXPIRES _____

WASHOE COUNTY COMMUNITY SERVICES DEPT. _____
DATE

NAME: _____

TITLE: _____

STATE OF NEVADA
COUNTY OF WASHOE S.S.

ON THIS _____ DAY OF _____, 2019, _____ OF THE WASHOE COUNTY COMMUNITY SERVICES DEPARTMENT, DID PERSONALLY APPEAR BEFORE ME TO PERSONALLY ACKNOWLEDGE THIS INSTRUMENT.

NOTARY PUBLIC

MY COMMISSION EXPIRES _____

COUNTY SURVEYOR'S CERTIFICATE:

I HEREBY CERTIFY THAT I HAVE EXAMINED THIS PLAT AND PERFORMED A TECHNICAL MAP CHECK OF THE GEOMETRIC DATA SHOWN HEREON AND THAT I AM SATISFIED THAT THE MAP IS TECHNICALLY CORRECT.

WAYNE HANDROCK, PLS
WASHOE COUNTY SURVEYOR

WATER AND SEWER RESOURCE CERTIFICATE:

THE PROJECT DEPICTED ON THIS MAP IS IN CONFORMANCE WITH THE PROVISIONS OF ARTICLE 422 OF WASHOE COUNTY CHAPTER 110 (DEVELOPMENT CODE).

WASHOE COUNTY COMMUNITY SERVICES DEPT. _____
DATE

NAME: _____

TITLE: _____

COMMUNITY SERVICES CERTIFICATE:

THE TENTATIVE MAP FOR SPANISH SPRINGS STORAGE PARTNERS LLC, WAS APPROVED BY THE WASHOE COUNTY PLANNING COMMISSION ON THE _____ DAY OF _____, 2019.

THIS FINAL MAP, OFFICIAL PLAT FOR SPANISH SPRINGS STORAGE PARTNERS LLC, MEETS ALL APPLICABLE STATUTES, ORDINANCES AND CODE PROVISIONS, IS IN SUBSTANTIAL CONFORMANCE WITH THE TENTATIVE MAP AND ITS CONDITIONS, WHICH ARE INCORPORATED HEREIN BY THIS REFERENCE, AND THOSE CONDITIONS HAVE BEEN SATISFIED FOR RECORDATION OF THIS MAP, EXCEPT THAT THE "OPERATIONAL CONDITIONS" CONTAINED IN THE RECORDED ACTION ORDER SHALL REMAIN IN FULL FORCE EFFECT IN PERPETUITY.

THIS MAP IS APPROVED AND ACCEPTED FOR RECORDATION THIS _____ DAY OF _____, 2019 BY THE WASHOE COUNTY PLANNING AND BUILDING DIRECTOR.

DATE

MOJRA HAUENSTEIN
WASHOE COUNTY DIRECTOR OF PLANNING AND BUILDING

SURVEYOR'S CERTIFICATE:

I GLEN C. ARMSTRONG, A PROFESSIONAL LAND SURVEYOR REGISTERED IN THE STATE OF NEVADA, CERTIFY THAT:

- 1. THIS PLAT REPRESENTS THE RESULTS OF A SURVEY CONDUCTED UNDER MY DIRECT SUPERVISION AT THE INSTANCE OF SPANISH SPRINGS STORAGE PARTNERS LLC.
- 2. THE LANDS SURVEYED LIE WITHIN A PORTION OF THE NORTHEAST 1/4 OF SECTION 23, T21N., R.20E., M.D.M., CITY OF SPARKS, WASHOE COUNTY, NEVADA, AND THE SURVEY WAS COMPLETED ON MARCH 18, 2019.
- 3. THIS PLAT COMPLIES WITH THE APPLICABLE STATE STATUTES AND ANY LOCAL ORDINANCES IN EFFECT ON THE DATE THAT THE GOVERNING BODY GAVE ITS FINAL APPROVAL.
- 4. THE MONUMENTS DEPICTED ON THE PLAT ARE OF THE CHARACTER SHOWN, OCCUPY THE POSITIONS INDICATED AND ARE OF SUFFICIENT NUMBER AND DURABILITY.

GLEN C. ARMSTRONG
PROFESSIONAL LAND SURVEYOR NO. 16451

FOR REVIEW

COUNTY RECORDER'S CERTIFICATE

OFFICIAL PLAT FOR
SPANISH SPRINGS STORAGE PARTNERS LLC
A MERGER AND RE-SUBDIVISION OF PARCELS 1-3 OF PARCEL MAP No. 4195
SITUATED IN THE NORTHEAST 1/4 OF SECTION 23
TOWNSHIP 21 NORTH, RANGE 20 EAST, M.D.M.
SPARKS WASHOE COUNTY NEVADA

FILE NO. _____
FEE: _____
FILED FOR RECORD AT THE REQUEST OF _____
ON THIS _____ DAY OF _____, 2019,
AT _____ MINUTES PAST _____ O'CLOCK ____M.,
OFFICIAL RECORDS OF WASHOE COUNTY, NEVADA.

COUNTY RECORDER
BY: _____
DEPUTY

P.O. BOX 3299
RENO, NV 89505
648 LANDER STREET
RENO, NV 89509
PHONE (775) 786-5111
WWW.USGEOMATICS.COM
INFO@USGEOMATICS.COM

NOTES:

- 1) ACCORDING TO FEMA FLOOD INSURANCE RATE MAP NO. 32031C2865G, REVISED MARCH 16, 2009, THE SUBJECT PROPERTY SHOWN HEREON IS LOCATED ENTIRELY WITHIN UNSHADED ZONE X (AREAS DETERMINED TO BE OUTSIDE THE 0.2% ANNUAL CHANCE FLOODPLAIN).
- 2) A DECLARATION OF COVENANTS FOR THE SUBJECT PROPERTY WAS RECORDED NOVEMBER 5, 1999 AS DOCUMENT NO. 2395858.
- 3) MINERAL RESERVATIONS CONTAINED IN DEED RECORDED JUNE 8, 2004 AS DOCUMENT NO. 3050525.
- 4) THE PARCELS ARE FOR NON-RESIDENTIAL USE ONLY.
- 5) SEWAGE DISPOSAL SHALL BE BY COMMUNITY SEWER ONLY.
- 6) WATER FOR FIRE PROTECTION SHALL BE PROVIDED AT BUILDING PERMIT FOR THE PARCELS PRIOR TO ANY STORAGE OF COMBUSTIBLES ON SITE. FIRE FLOWS SHALL MEET TABLE III-A OF THE UNIFORM FIRE CODE.
- 7) PRIOR TO THE ISSUANCE OF BUILDING PERMITS FOR THE PARCELS, WATER AND SEWAGE IMPROVEMENT PLANS FOR EACH PARCEL AND THE SUBSEQUENT CONSTRUCTION SHALL BE IN ACCORDANCE WITH WASHOE COUNTY REQUIREMENTS.
- 8) WATER DEMAND FOR COMMERCIAL PROPERTIES ARE NOT DETERMINED UNTIL THE TIME OF APPLICATION FOR A BUILDING PERMIT.
- 9) PER WASHOE COUNTY ORDINANCE, WATER SERVICE CONNECTION FEES SHALL BE PAID TO THE DEPARTMENT OF WATER RESOURCES, AND WATER RIGHTS SHALL BE ALLOCATED FROM PREVIOUSLY DEDICATED WATER RIGHTS TO WASHOE COUNTY PRIOR TO THE ISSUANCE OF A BUILDING PERMIT.
- 10) PRIOR TO THE ISSUANCE OF A SANITARY SEWER WILL SERVE LETTER OR A BUILDING PERMIT, SANITARY SEWER CONNECTION FEES IN ACCORDANCE WITH WASHOE COUNTY ORDINANCE SHALL BE PAID. CONNECTION FEES FOR COMMERCIAL DEVELOPMENT WILL BE DETERMINED UPON WASTE FIXTURE UNIT COUNTS. THESE FIXTURE UNIT COUNTS SHALL BE PREPARED BY THE APPLICANT'S ARCHITECT OR ENGINEER IN ACCORDANCE WITH THE UNIFORM PLUMBING CODE AND SHALL BE SUBMITTED TO THE WASHOE COUNTY DEPARTMENT OF WATER RESOURCES FOR REVIEW AND APPROVAL.
- 11) THE TRAFFIC MITIGATION PLAN REQUIRED BY SECTION 4.4.1 OF THE SPANISH SPRINGS SPECIFIC PLAN SHALL BE REVIEWED AND APPROVED BY THE DEPARTMENT OF COMMUNITY DEVELOPMENT AND THE COUNTY ENGINEER PRIOR TO THE ISSUANCE OF A BUILDING PERMIT.
- 12) A PUBLIC UTILITY AND CABLE TV EASEMENT IS HEREBY GRANTED WITHIN EACH PARCEL FOR THE EXCLUSIVE PURPOSE OF INSTALLING AND MAINTAINING UTILITY AND CABLE TV FACILITIES TO SAID PARCELS AND THE RIGHT TO EXIT SAID PARCELS WITH SAID FACILITIES FOR THE PURPOSE OF SERVING ADJACENT LOTS AT LOCATIONS MUTUALLY AGREED UPON BY THE OWNER OF RECORD AT THAT TIME, AND THE UTILITY AND CABLE TV COMPANIES.
- 13) EASEMENTS FOR PERPETUAL AVIGATION FOR RIGHT OF FLIGHT WERE RECORDED JUNE 18, 2001 AS DOCUMENT NO. 2564445 AND JANUARY 17, 2002 AS DOCUMENT NO. 2641850.

LEGEND:

- SUBJECT TRACT PROPERTY LINES
- - - ADJACENT PROPERTY LINES
- - - RIGHT-OF-WAY CENTERLINES
- - - EASEMENT LINES
- FOUND 5/8" REBAR WITH CAP, PLS 4043
- SET 5/8" REBAR WITH CAP, PLS 16451
- ◆ FOUND CENTERLINE MONUMENT, BRASS CAP
- ◆ NEVADA GPS NETWORK CONTROL MONUMENT
- PUE PUBLIC UTILITY EASEMENT
- PDE PRIVATE DRAINAGE EASEMENT
- PFE PRIVATE FIRE LINE EASEMENT
- SSE PLOWED SNOW STORAGE EASEMENT
- TSE TRAFFIC CONTROL SIGNAGE EASEMENT
- ▨ COMMON AREA WITHIN BUILDING
- ⊕ GRAPHIC BORDER
- ⊕ PLSS CORNER

BASIS OF BEARING:

NORTH WAS ESTABLISHED WITH GPS OBSERVATIONS (NEVADA STATE PLANE COORDINATES, WEST ZONE, NAD83) OF NDOT MONUMENT "1533002", WHICH HAS COORDINATES PUBLISHED ONLINE BY THE NEVADA DEPARTMENT OF TRANSPORTATION.

ALL COORDINATES AND DISTANCES SHOWN HEREON HAVE GROUND VALUES. THE WASHOE COUNTY COMBINED FACTOR OF 0.999802100 WAS USED TO SCALE GRID COORDINATES TO GROUND COORDINATES.

GRID-TO-GROUND SCALE FACTOR = 1.000197939
GROUND-TO-GROUND SCALE FACTOR = 0.999802100

AREA SUMMARY:

| COMMON AREA | |
|----------------|---|
| BUILDING | = ± 1,458 SQUARE FEET |
| NON-BUILDING | = ± 97,504 SQUARE FEET (± 2.24 ACRES) |
| BUILDING AREAS | |
| BUILDING A | = ± 4,890 SQUARE FEET |
| BUILDING B | = ± 22,820 SQUARE FEET |
| BUILDING C | = ± 6,744 SQUARE FEET |
| BUILDING D | = ± 6,620 SQUARE FEET |
| BUILDING E | = ± 19,202 SQUARE FEET |
| TOTAL | = ± 159,238 SQUARE FEET (± 3.66 ACRES) |

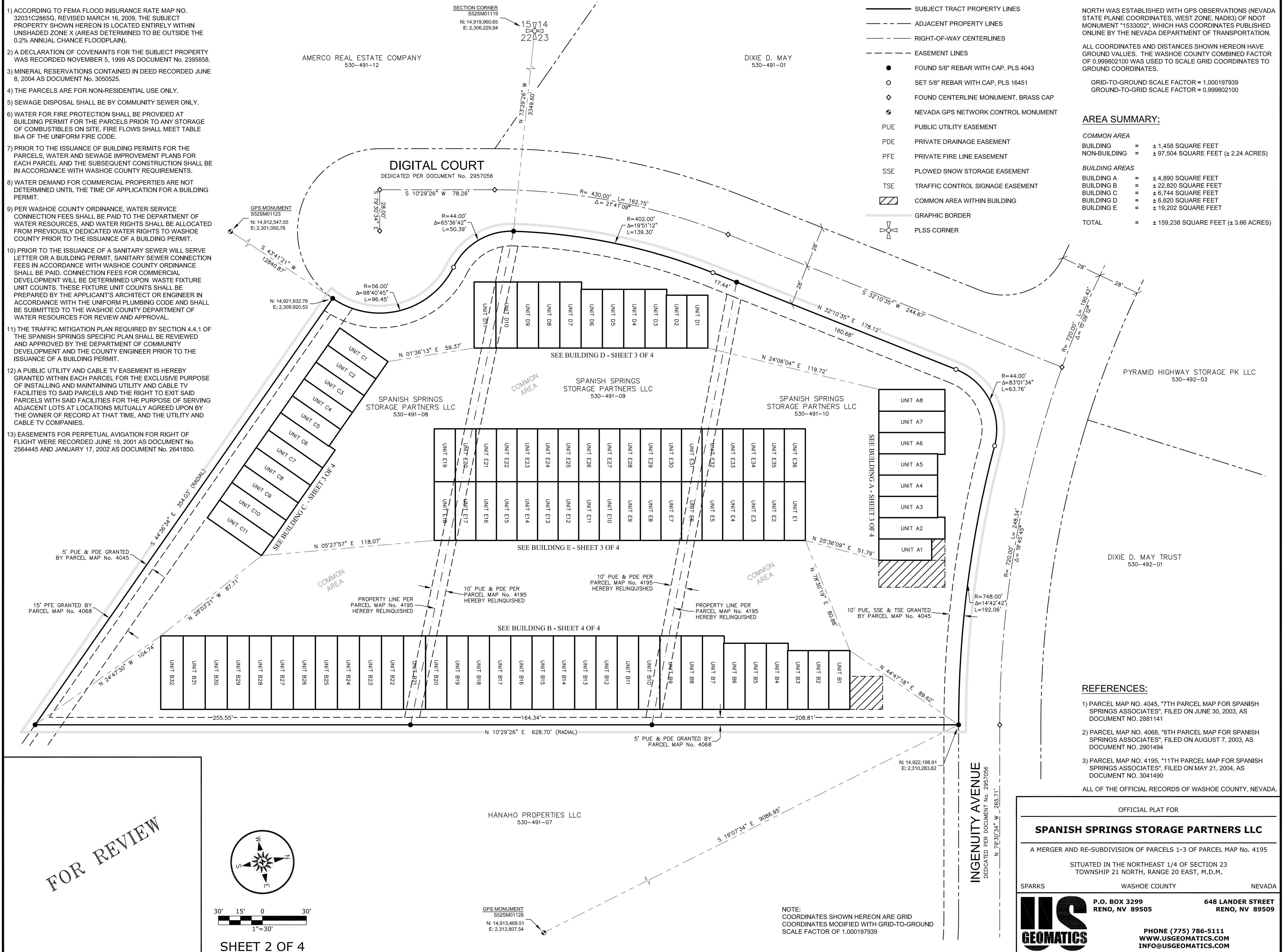

FOR REVIEW

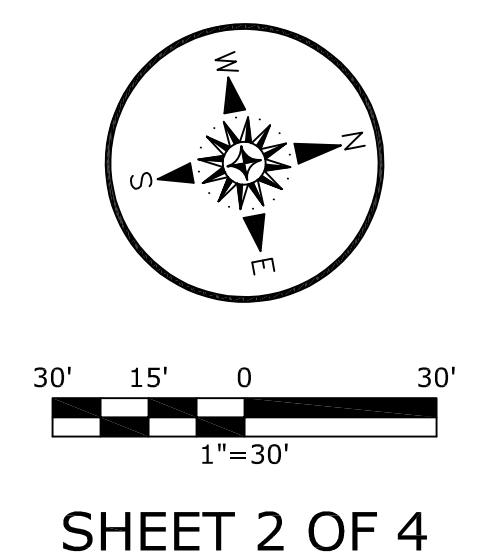

REFERENCES:

- 1) PARCEL MAP NO. 4045, "7TH PARCEL MAP FOR SPANISH SPRINGS ASSOCIATES", FILED ON JUNE 30, 2003, AS DOCUMENT NO. 2881141
 - 2) PARCEL MAP NO. 4068, "8TH PARCEL MAP FOR SPANISH SPRINGS ASSOCIATES", FILED ON AUGUST 7, 2003, AS DOCUMENT NO. 2901494
 - 3) PARCEL MAP NO. 4195, "11TH PARCEL MAP FOR SPANISH SPRINGS ASSOCIATES", FILED ON MAY 21, 2004, AS DOCUMENT NO. 3041490
- ALL OF THE OFFICIAL RECORDS OF WASHOE COUNTY, NEVADA.

OFFICIAL PLAT FOR

SPANISH SPRINGS STORAGE PARTNERS LLC

A MERGER AND RE-SUBDIVISION OF PARCELS 1-3 OF PARCEL MAP NO. 4195

SITUATED IN THE NORTHEAST 1/4 OF SECTION 23
TOWNSHIP 21 NORTH, RANGE 20 EAST, M.D.M.

SPARKS WASHOE COUNTY NEVADA

US GEOMATICS

P.O. BOX 3299
RENO, NV 89505

648 LANDER STREET
RENO, NV 89509

PHONE (775) 786-5111
WWW.USGEOMATICS.COM
INFO@USGEOMATICS.COM

NOTE:
COORDINATES SHOWN HEREON ARE GRID
COORDINATES MODIFIED WITH GRID-TO-GROUND
SCALE FACTOR OF 1.000197939

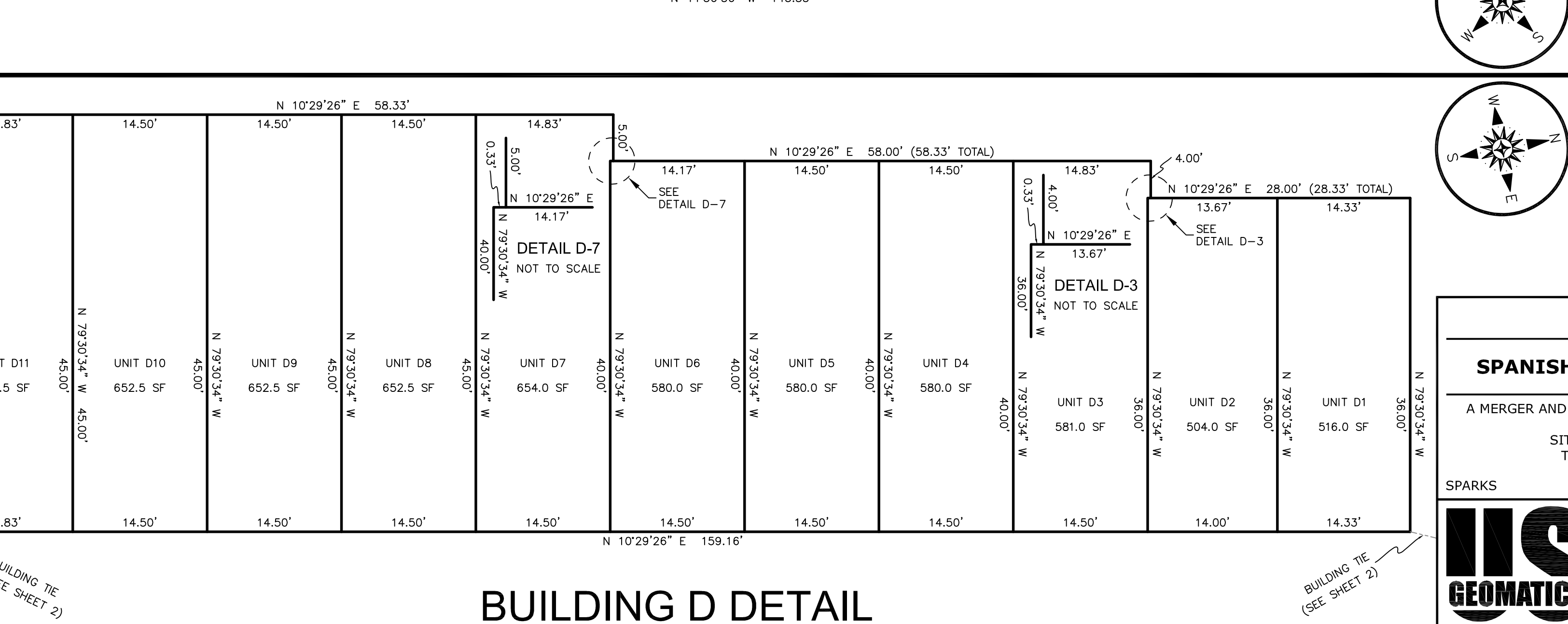
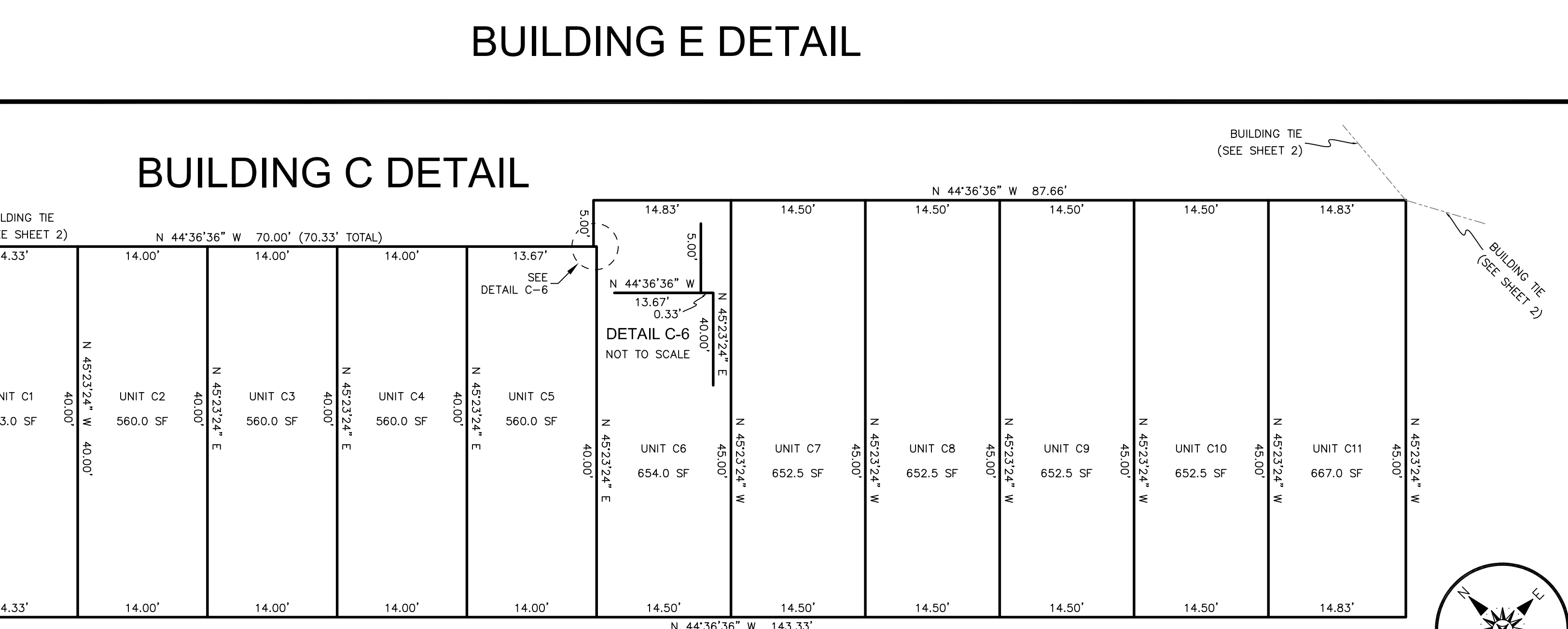
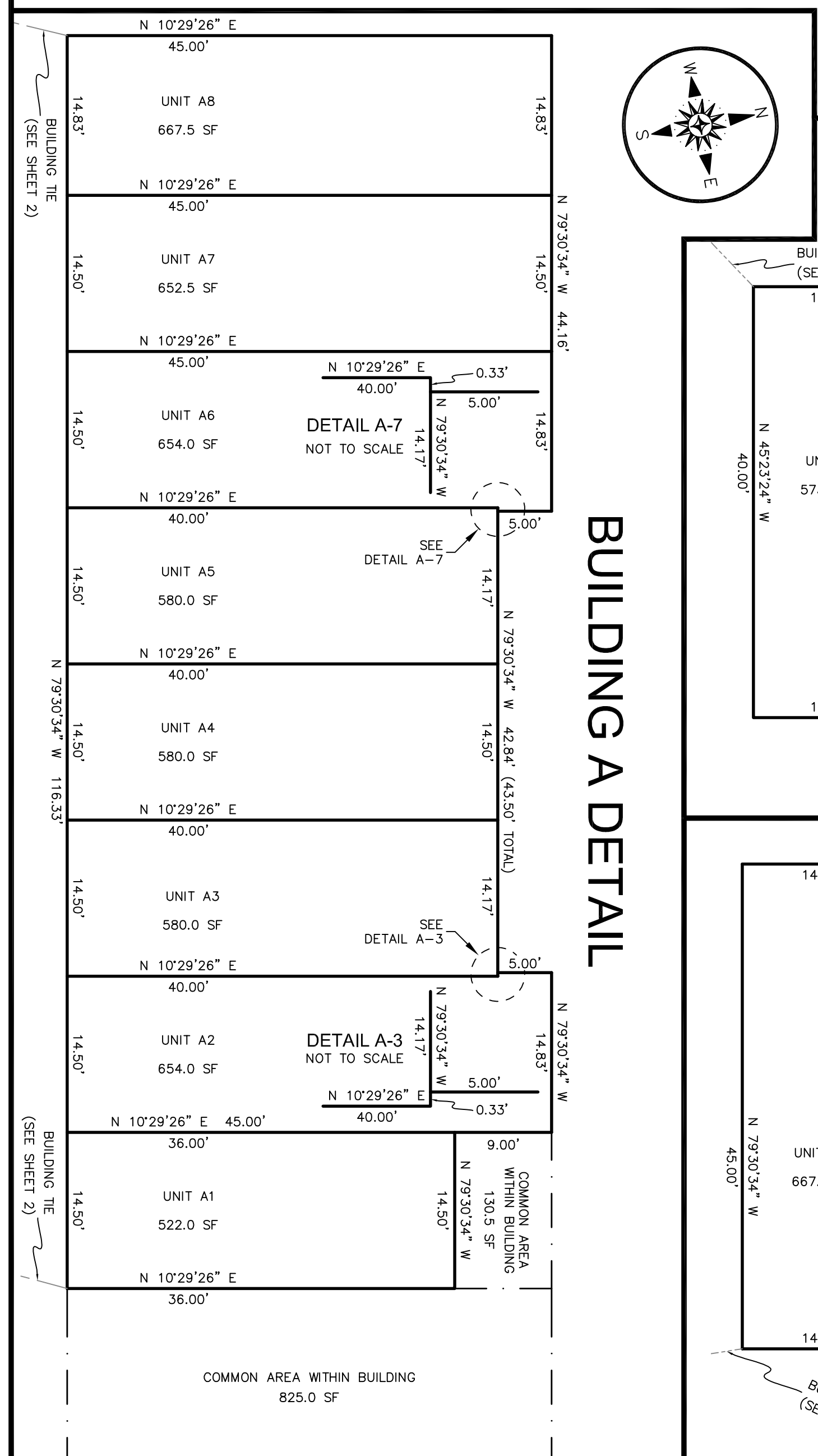
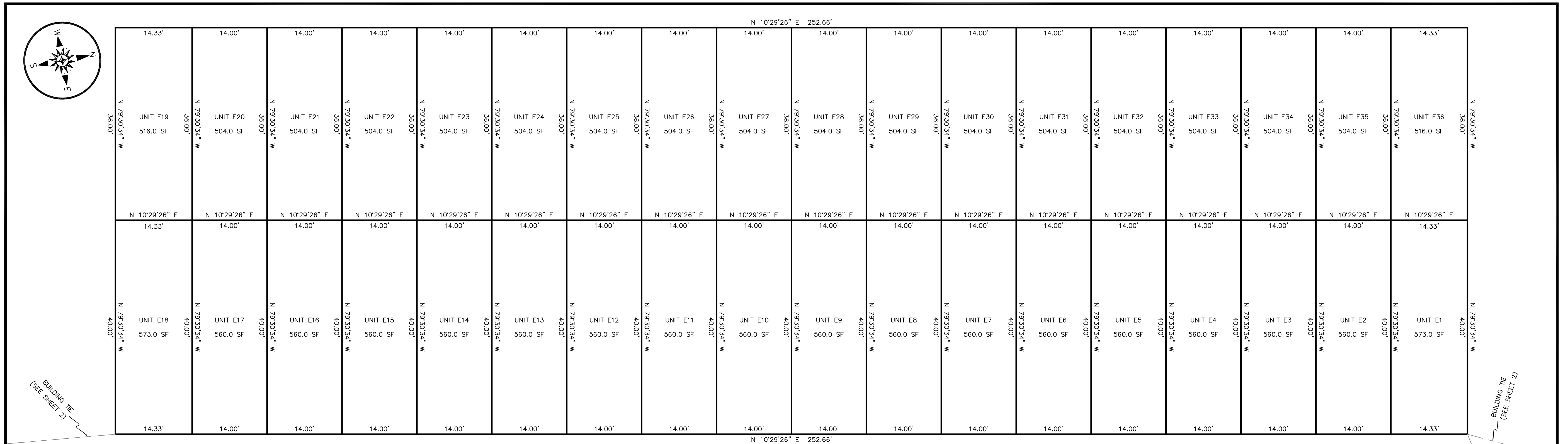

- LEGEND:**
- SUBJECT TRACT PROPERTY LINES
 - - - ADJACENT PROPERTY LINES
 - RIGHT-OF-WAY CENTERLINES
 - - - EASEMENT LINES
 - FOUND 5/8" REBAR WITH CAP, PLS 4043
 - ◇ FOUND CENTERLINE MONUMENT, BRASS CAP
 - DIMENSION POINT, NOTHING FOUND OR SET

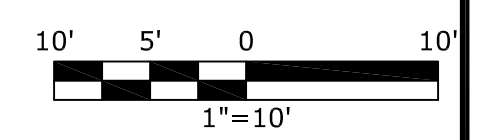

SHEET 3 OF 4

FOR REVIEW

OFFICIAL PLAT FOR

SPANISH SPRINGS STORAGE PARTNERS LLC

A MERGER AND RE-SUBDIVISION OF PARCELS 1-3 OF PARCEL MAP No. 4195

SITUATED IN THE NORTHEAST 1/4 OF SECTION 23
TOWNSHIP 21 NORTH, RANGE 20 EAST, M.D.M.

SPARKS WASHOE COUNTY NEVADA

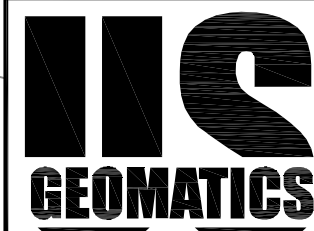
P.O. BOX 3299
RENO, NV 89505

648 LANDER STREET
RENO, NV 89509

PHONE (775) 786-5111
 WWW.USGEOMATICS.COM
 INFO@USGEOMATICS.COM

DRAINAGE REPORT

FOR

Luxelocker



10/9/19

APN:

530-491-08, 530-491-09, and 530-491-10

Prepared for:

Consolidated Construction Co Inc.

4300 N Richmond St.

Appleton, WI 54913

Prepared by:



730 Sandhill Road, Suite 250
Reno, Nevada 89521

August 1st, 2019
Revised October 9, 2019
Job Number: 19042

TABLE OF CONTENTS

| | | |
|----|--|--------|
| 1. | GENERAL LOCATION AND DEVELOPMENT DESCRIPTION | |
| A. | INTRODUCTION | Page 2 |
| B. | SITE LOCATION | Page 2 |
| C. | PROJECT DESCRIPTION | Page 2 |
| D. | HYDROLOGIC ANALYSIS | Page 2 |
| E. | FLOODPLAIN INFORMATION | Page 3 |
| F. | GENERAL DESCRIPTION OF | Page 3 |
| G. | COMPLIANCE WITH REGULATIONS AND ADOPTED PLANS | Page 3 |
| H. | METHODOLGY | Page 3 |
| 2. | PROPOSED DRAINAGE FACILITIES | Page 5 |
| A. | FACILITY DESIGN CALCULATIONS | Page 5 |
| 3. | CONCLUSION | Page 5 |

EXHIBITS

| | |
|------|--------------------|
| EX-1 | VICINITY MAP |
| EX-2 | EXISTING BASIN MAP |
| EX-3 | PROPOSED BASIN MAP |
| EX-4 | FEMA MAP |

APPENDIX

| | |
|---|-----------------------------|
| A | REGIONAL DRAINAGE CRITERIA |
| B | DRAINAGE BASIN CALCULATIONS |
| C | BASIN OUTLET CALCULATIONS |

GENERAL LOCATION AND DEVELOPMENT DESCRIPTION

INTRODUCTION

The following report represents the hydrologic and hydraulic analysis for the LuxeLocker facility which will be located on 3.66 acres of vacant land site within the Spanish Springs Business Park. The site is located at 11455 Digital Court, and will be composed of three sites to be combined with APNs 530-491-08, 530-491-09, and 530-491-10. This report will address the Truckee Meadows Regional Design Manual (TMRDM), Washoe County Stormwater & Washoe County Boneyard Flat Closed Basin Interim Drainage Policy requirements including calculations and results to show how the project meets these requirements.

SITE LOCATION

The proposed project is located within the Spanish Springs Business Park on three vacant parcels totaling 3.66 acres, with APNs 530-491-08, 530-491-09, and 530-491-10. The parcel is bordered to the north by Ingenuity Avenue, to the west by Digital Court, it is currently undeveloped to the east and south. The project is located in Section 22, Township 21 North, Range 20 East, Mount Diablo Meridian. See Exhibit 1 for a general Vicinity Map.

PROJECT DESCRIPTION

LuxeLocker is constructing five new buildings that will serve as storage units. Building A is 5,688 sf, Building B is 23,327 sf, Building C is 6,745 sf, Building D is 6,620 sf, and Building E is 19,203 sf. Total square footage of buildings on the site comes out to 61,583 sf. There will be drives constructed from Ingenuity Avenue on the north and off of Digital Court in the west.

The overall site was originally included with the “Master Grading and Drainage Report” prepared by C&M Engineering and Design, dated January 2004. Within this report, this site will drain to a subsurface stormwater storage system and overflow to an existing storm drain stub. From the conveyance points the site runoff will ultimately drain into the dry lake of Boneyard Flat. Per the Master Drainage Study and Washoe County, the proposed development requires detention that will be provided in the way of a subsurface storm water storage system.

Based on the Master Drainage Study, the existing drainage infrastructure was designed to detain some increased flows (based only on the existing stub connection capacity from our developed site to Boneyard Flat). The site will also retain onsite the increase in stormwater runoff volume due to development.

HYDROLOGIC ANALYSIS

In the existing condition the site consists of a single drainage basin as shown on Exhibit 2. The site currently slopes from south to north starting at an elevation of 4535’ and having an elevation in the north of 4530’. The hydrologic analysis provided in this report includes calculations for the proposed development’s 10-year and 100-year peak discharges. All calculations were performed in accordance with Washoe County Development Code, the Truckee Meadows Regional Design Manual (TMRDM) and the Washoe County Boneyard Flat Closed Basin Interim Drainage Policy.

FLOODPLAIN INFORMATION

According to Flood Insurance Rate Map panel 32031C2865G, dated March 16, 2009, the entire site is located within Unshaded Flood Zone X. Unshaded Flood Zone X is defined as an area of minimal flood hazard, determined to be outside the 500-year flood. A copy of the FEMA map is enclosed as Exhibit 3.

GENERAL DESCRIPTION OF ON-SITE FACILITIES

The proposed site will drain into an underground retention system designed using the R Tank subsurface storage system. The system will receive stormwater from one inlet located directly above the system. An existing 24" storm drain stub will serve as an overflow. The R Tank stormwater modules allow for adequate storage and will effectively detain, and infiltrate captured stormwater.

COMPLIANCE WITH REGULATIONS AND ADOPTED PLANS

The design criteria which has been used for this drainage analysis is in compliance with the Washoe County Storm Drainage Standards, Truckee Meadows Regional Drainage Manual & The Washoe County Boneyard Flat Closed Basin Interim Drainage Policy.

METHODOLOGY

RATIONAL METHOD

The rational method was used to determine the peak flows. The parameters for this method are:

1. The drainage area (A, acres)
2. Time of Concentration (T_c , minutes)
3. Runoff Coefficient (C)
4. Rainfall Intensity (i, inches per hour)

The time of concentration is calculated based on the Truckee Meadows Regional Drainage Manual equation:

$$t_c = t_i + t_t$$

In which t_c = time of concentration (minutes)
 t_i = initial, inlet, or overland flow time (minutes)
 t_t = travel time in the ditch, channel, gutter, storm sewer, etc. (minutes)

Due to the relatively small size of the site and sub areas and the high runoff potential within commercial developments, the minimum T_c of 10 minutes was used in this proposed sub-basin analysis.

Rainfall intensities were obtained from the rainfall intensity-duration-frequency curves for the project location as determined by NOAA. (See Appendix A)

From the Truckee Meadows Regional Drainage Manual., the following runoff coefficients were used (See Appendix A):

| | | |
|-------------------------|--------|--------|
| | 5-yr | 100-yr |
| Impervious | C=0.88 | C=0.93 |
| Building | C=0.85 | C=0.87 |
| Undeveloped/Landscaping | C=0.20 | C=0.50 |

The peak runoff is calculated using the following equation: $Q=CiA$

SCS METHOD

SCS runoff curve number method is used to determine the required retention volume for the 10-day 100-yr storm. The SCS Runoff Curve Number (CN) method is described in detail in NEH-4 (SCS 1985). The SCS runoff equation is:

$$Q = \frac{(P - I_a)^2}{(P - I_a) + S}$$

Where:

- Q = runoff (in)
- P = rainfall (in)
- S = potential maximum retention after runoff begins (in)
- I_a = initial abstraction (in)

Initial abstraction (I_a) is all losses before runoff begins is approximated by the following empirical equation:

$$I_a = 0.2S$$

Substitution of I_a provides the following equation:

$$Q = \frac{(P - 0.2S)^2}{(P + 0.8S)}$$

S is related to the soil and cover conditions of the watershed through the CN. CN has a range of 0 to 100, and S is related to CN by:

$$S = \frac{1000}{CN} - 10$$

Runoff Volume is determined by

$$Runoff Volume (ft^3) = Q \left(\frac{1 ft}{12 in} \right) Area$$

Where:

$$\text{Area} = \text{Area of the specific land cover (ft}^2\text{)}$$

PROPOSED DRAINAGE FACILITIES

FACILITY DESIGN CALCULATIONS

The proposed site is composed of a single drainage basin. The entirety of the site is routed to an underground storm drainage system. The underground storm drainage system will route to the R Tank subsurface storage system located near the north of the site. The roof drains for the buildings will all drain via downspout and sheet flow into this system. The underground storage is proposed to connect to an existing storm drain stub to act as overflow.

All Calculations have been provided in appendix B and C. A summary of these results are below in the provided tables.

BASIN SIZING

In order to account for the increased volume of runoff generated, as well as the flood plain storage volumes within the 100-year flood plain, a volumetric analysis was performed based on the 100-year, 10-day storm event. Basin sizing calculations are referenced in Appendix B.

Table 3 – Basin Sizing

| | 100 YR Required Volume (c.f.) | 100 YR Provided Volume (c.f.) |
|----------------|--|--|
| Basin 1 | 10,542 | 10,524 |

CONCLUSION

All designed storm drain facilities are effective in controlling storm runoff. In addition, the storm drain facilities are in compliance with the following:

- FEMA requirements - No buildings are proposed within the existing or proposed 100-year flood plain boundaries.
- Drainage Laws – As designed, the drainage system shall promote and preserve the general health, welfare, and economic being of the region.
- Washoe County Development Code – All items of concern such as reasonable use of and diversion of drainage have been addressed.
- All storm drain and flood control improvements have been designed to meet or exceed the design standards as set forth in the Washoe County Storm Drainage Standards, the Truckee Meadows Regional Drainage Manual & the Washoe County Boneyard Flat Closed Basin Interim Drainage Policy.

EXHIBITS

DRAWN: O.K.B.

DATE: 05/08/18

DESCRIPTION: VICINITY MAP

APN : 530-491-08, 09 & 10

SUBMITTAL:

EX-1

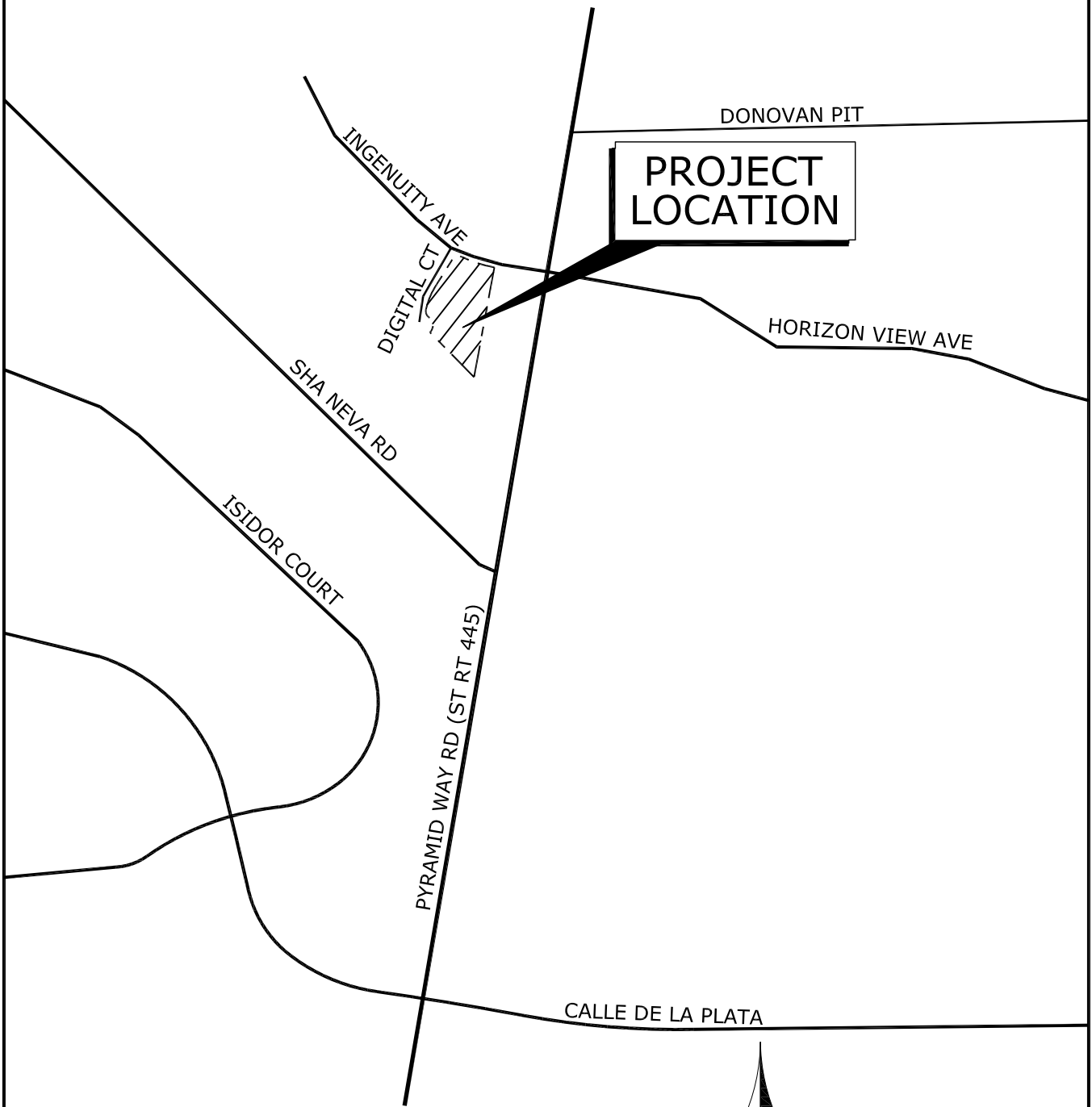

VICINITY MAP

SCALE: N.T.S.



PROJECT/CLIENT:

JOB #: 19042

LUXELOCKER

11455 DIGITAL COURT, SPANISH SPRINGS, NEVADA

CONSOLIDATED CONSTRUCTION CO INC.
APPLETON, WI



**TECTONICS
DESIGN GROUP**

730 Sandhill Road, Suite 250, Reno, NV 89521
www.tectonicsdesigngroup.com

tel 775-824-9988
fax 775-824-9986

| PROJECT QUANTITIES | |
|-----------------------|--------------|
| DRAINAGE BASIN 1 | |
| BUILDING AREA: | 0 S.F. |
| LANDSCAPE AREA: | 159,238 S.F. |
| IMPERVIOUS AREA: | 0 S.F. |
| TOTAL (CN VALUE=0.85) | 159,238 S.F. |

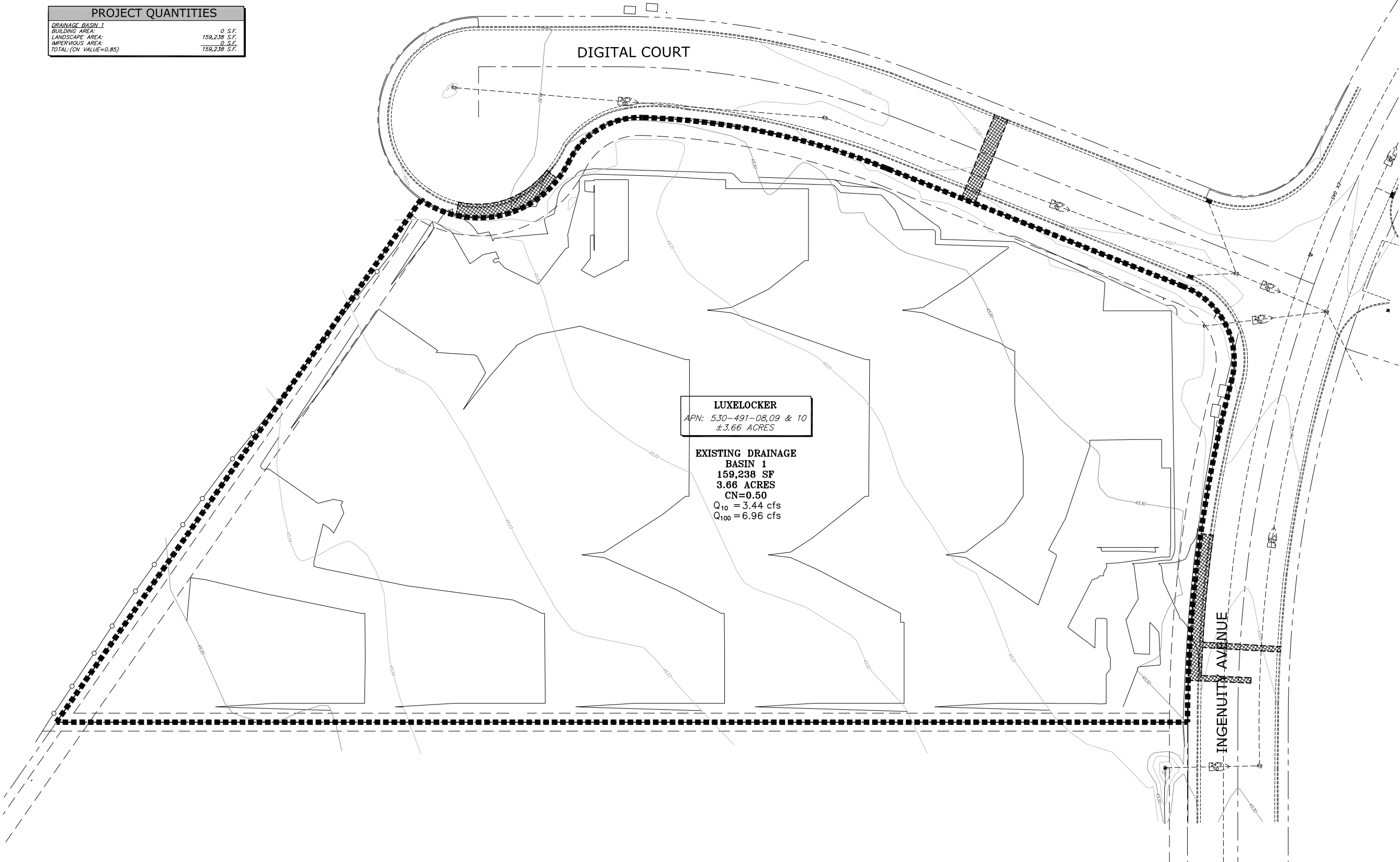

1"=20'-0" LUXELOCKER REINO 19042_EX-2

EXISTING BASIN MAP
 SCALE: N.T.S.



| | | |
|-------------------|---|-------------------------|
| COPYRIGHT: | All drawings herein are the property of Tectonics Design Group and may not be reproduced or used in any capacity without the written authorization of Tectonics Design Group. | |
| | DRAWN: | N.D.J. |
| DESIGNED: | N.D.J. | |
| | CHECKED/STAMPED: | MATT K. RASMUSSEN, P.E. |
| STAMP: | PRELIMINARY DESIGN | |
| DESIGNER: | TECTONICS DESIGN GROUP 730 Sandhill Rd., #250, Reno, Nevada 89521 tel 775-824-9988 fax 775-824-9986 www.tectonicsdesigngroup.com | |
| PROJECT/CLIENT: | LUXELOCKER 11455 Digital Court, Spanish Springs, Nevada Consolidated Construction Co Inc. Appleton, WI | |
| #: 19042 | DATE: | SUBMITTAL |
| 5/14/19 | | |
| SUBMITTAL RECORD: | EXISTING BASIN MAP | |
| SHEET TITLE: | EXISTING BASIN MAP | |
| SHEET: | EX-2 | |

| PROJECT QUANTITIES | |
|-----------------------|--------------|
| DRAINAGE BASIN 1 | |
| BUILDING AREA: | 62,490 S.F. |
| LANDSCAPE AREA: | 29,331 S.F. |
| IMPERVIOUS AREA: | 87,417 S.F. |
| TOTAL (CN VALUE=X.XX) | 159,238 S.F. |

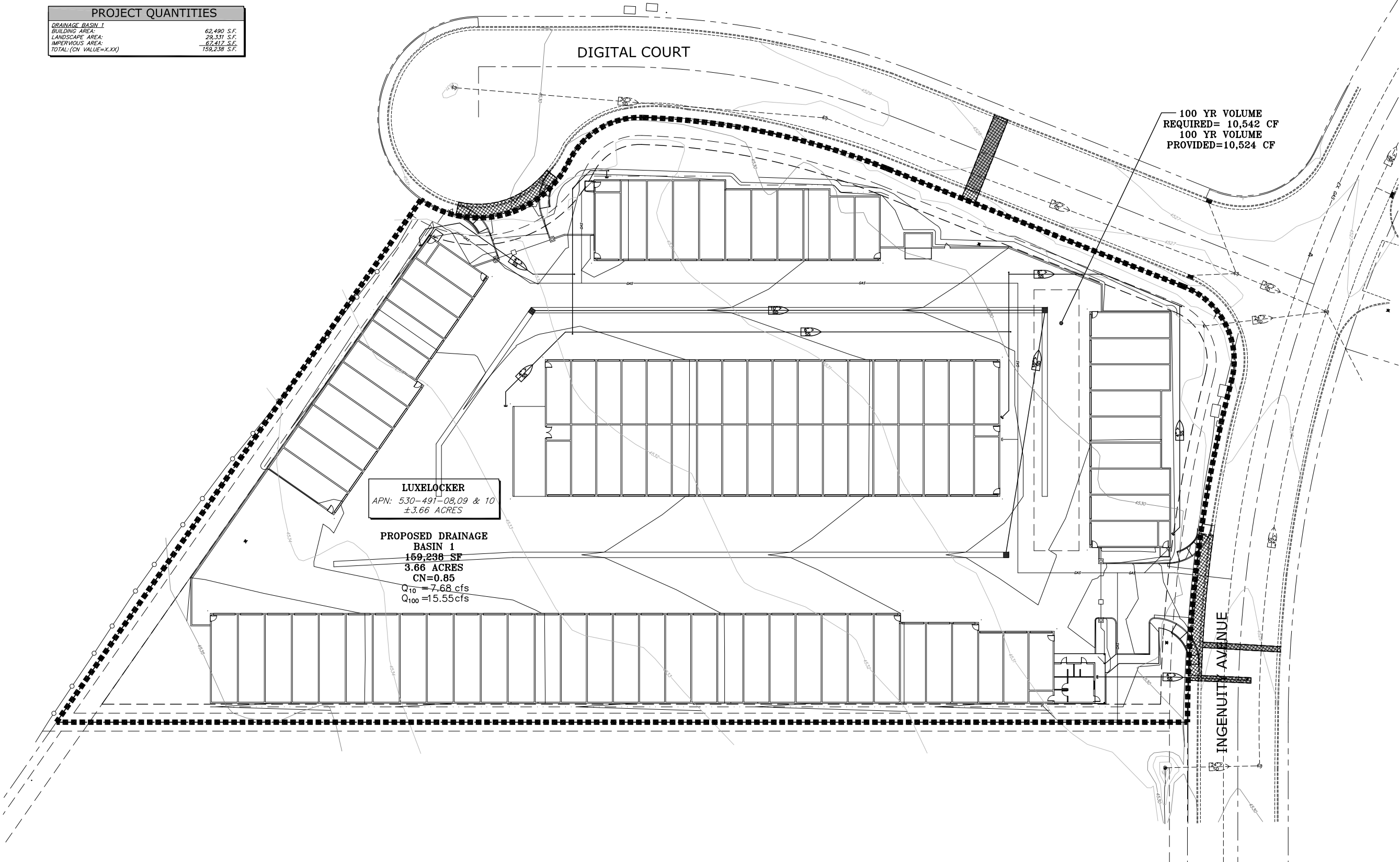

PROPOSED BASIN MAP
SCALE: N.T.S.



COPYRIGHT: All drawings herein are the property of Tectonics Design Group and may not be reproduced or used in any capacity without the written authorization of Tectonics Design Group.

DRAWN: N.D.J.
DESIGNED: N.D.J.
CHECKED/STAMPED: MATT K. RASMUSSEN, P.E.

PRELIMINARY DESIGN

DESIGNER: **TECTONICS DESIGN GROUP**
730 Sandhill Rd., # 250, Reno, Nevada 89521
tel 775-824-9988
fax 775-824-9986
www.tectonicsdesigngroup.com

PROJECT/CLIENT: # 19042
DATE: 5/14/19
SUBMITTAL RECORD: SUBMITTAL
SHEET TITLE: PROPOSED BASIN MAP

LUXELOCKER
11455 Digital Court, Spanish Springs, Nevada
Consolidated Construction Co Inc.
Appleton, WI

1"=20'-0" LUXELOCKER RENO 19042_EX-3

National Flood Hazard Layer FIRMette



Legend

SEE FIS REPORT FOR DETAILED LEGEND AND INDEX MAP FOR FIRM PANEL LAYOUT

| | |
|--|--|
| | Without Base Flood Elevation (BFE) Zone A, V, A99 |
| | With BFE or Depth Zone AE, AO, AH, VE, AR Regulatory Floodway |

| | |
|--|---|
| | 0.2% Annual Chance Flood Hazard, Areas of 1% annual chance flood with average depth less than one foot or with drainage areas of less than one square mile Zone X |
| | Future Conditions 1% Annual Chance Flood Hazard Zone X |
| | Area with Reduced Flood Risk due to Levee. See Notes. Zone X |
| | Area with Flood Risk due to Levee Zone D |

| | |
|--|--|
| | Area of Minimal Flood Hazard Zone X |
| | Effective LOMIRs |
| | Area of Undetermined Flood Hazard Zone D |
| | Channel, Culvert, or Storm Sewer |
| | Levee, Dike, or Floodwall |

| | |
|--|---|
| | 20.2 Cross Sections with 1% Annual Chance |
| | 17.5 Water Surface Elevation |
| | Base Flood Elevation Line (BFE) |
| | Limit of Study |
| | Jurisdiction Boundary |
| | Coastal Transect Baseline |
| | Profile Baseline |
| | Hydrographic Feature |

| | |
|--|---------------------------|
| | Digital Data Available |
| | No Digital Data Available |
| | Unmapped |

The pin displayed on the map is an approximate point selected by the user and does not represent an authoritative property location.

This map complies with FEMA's standards for the use of digital flood maps if it is not void as described below. The basemap shown complies with FEMA's basemap accuracy standards.

The flood hazard information is derived directly from the authoritative NFHL web services provided by FEMA. This map was exported on **6/24/2019 at 11:04:46 AM** and does not reflect changes or amendments subsequent to this date and time. The NFHL and effective information may change or become superseded by new data over time.

This map image is void if the one or more of the following map elements do not appear: basemap imagery, flood zone labels, legend, scale bar, map creation date, community identifiers, FIRM panel number, and FIRM effective date. Map images for unmapped and undifferentiated areas cannot be used for regulatory purposes.

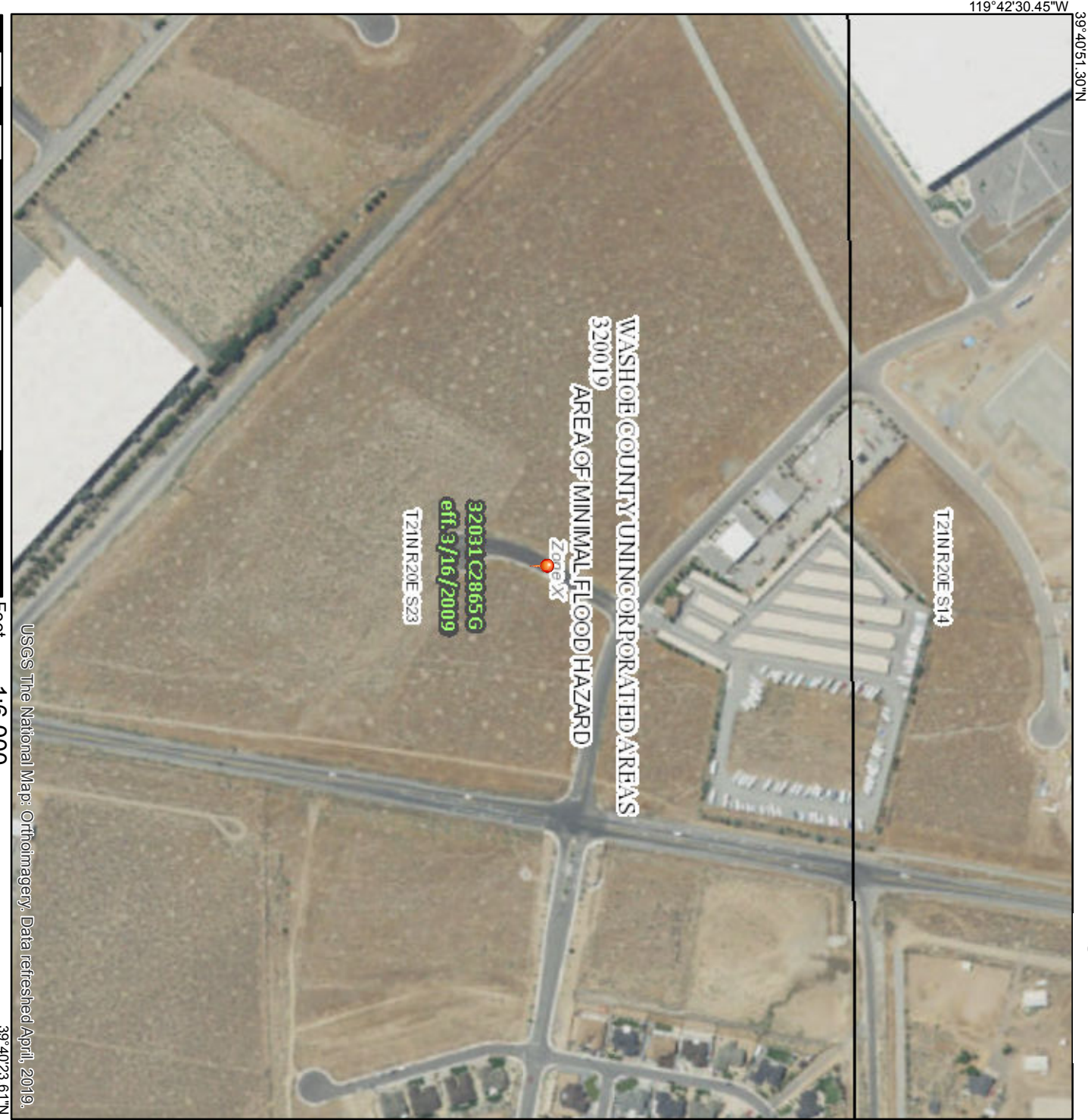

APPENDIX A

**REGIONAL DRAINAGE
CRITERIA**



NOAA Atlas 14, Volume 1, Version 5
Location name: Sparks, Nevada, USA*
Latitude: 39.6749°, Longitude: -119.7073°
Elevation: 4531.76 ft**



* source: ESRI Maps
 ** source: USGS

POINT PRECIPITATION FREQUENCY ESTIMATES

Sanja Perica, Sarah Dietz, Sarah Heim, Lillian Hiner, Kazungu Maitaria, Deborah Martin, Sandra Pavlovic, Ishani Roy, Carl Trypaluk, Dale Unruh, Fenglin Yan, Michael Yekta, Tan Zhao, Geoffrey Bonnin, Daniel Brewer, Li-Chuan Chen, Tye Parzybok, John Yarchoan

NOAA, National Weather Service, Silver Spring, Maryland

[PF_tabular](#) | [PF_graphical](#) | [Maps & aeriels](#)

PF tabular

| PDS-based point precipitation frequency estimates with 90% confidence intervals (in inches/hour)¹ | | | | | | | | | | |
|---|--|-------------------------------|-------------------------------|-------------------------------|-------------------------------|-------------------------------|-------------------------------|-------------------------------|-------------------------------|-------------------------------|
| Duration | Average recurrence interval (years) | | | | | | | | | |
| | 1 | 2 | 5 | 10 | 25 | 50 | 100 | 200 | 500 | 1000 |
| 5-min | 1.19 (0.996-1.37) | 1.49 (1.24-1.73) | 1.99 (1.68-2.35) | 2.47 (2.09-2.95) | 3.30 (2.71-3.98) | 4.08 (3.25-4.99) | 5.00 (3.89-6.23) | 6.14 (4.60-7.82) | 8.00 (5.66-10.6) | 9.73 (6.60-13.2) |
| 10-min | 0.906 (0.756-1.04) | 1.13 (0.942-1.32) | 1.51 (1.28-1.79) | 1.88 (1.58-2.24) | 2.51 (2.06-3.04) | 3.10 (2.48-3.80) | 3.81 (2.96-4.74) | 4.67 (3.49-5.96) | 6.10 (4.31-8.03) | 7.40 (5.02-10.0) |
| 15-min | 0.748 (0.628-0.864) | 0.932 (0.780-1.09) | 1.25 (1.06-1.48) | 1.56 (1.31-1.85) | 2.08 (1.71-2.51) | 2.56 (2.05-3.14) | 3.15 (2.44-3.92) | 3.86 (2.89-4.92) | 5.04 (3.56-6.64) | 6.12 (4.15-8.27) |
| 30-min | 0.504 (0.422-0.582) | 0.628 (0.524-0.732) | 0.842 (0.710-0.996) | 1.05 (0.882-1.25) | 1.40 (1.15-1.69) | 1.73 (1.38-2.11) | 2.12 (1.65-2.64) | 2.60 (1.94-3.31) | 3.39 (2.40-4.47) | 4.12 (2.80-5.57) |
| 60-min | 0.312 (0.261-0.360) | 0.388 (0.325-0.454) | 0.521 (0.439-0.616) | 0.649 (0.546-0.772) | 0.865 (0.711-1.05) | 1.07 (0.854-1.31) | 1.31 (1.02-1.63) | 1.61 (1.20-2.05) | 2.10 (1.49-2.77) | 2.55 (1.73-3.45) |
| 2-hr | 0.206 (0.182-0.238) | 0.256 (0.226-0.297) | 0.330 (0.288-0.383) | 0.395 (0.340-0.458) | 0.496 (0.416-0.578) | 0.586 (0.482-0.692) | 0.694 (0.556-0.830) | 0.837 (0.649-1.04) | 1.09 (0.808-1.40) | 1.33 (0.952-1.74) |
| 3-hr | 0.165 (0.147-0.188) | 0.205 (0.184-0.235) | 0.258 (0.229-0.294) | 0.301 (0.265-0.345) | 0.363 (0.315-0.417) | 0.418 (0.356-0.485) | 0.484 (0.405-0.570) | 0.578 (0.473-0.693) | 0.743 (0.589-0.940) | 0.897 (0.693-1.17) |
| 6-hr | 0.118 (0.105-0.133) | 0.147 (0.131-0.167) | 0.182 (0.162-0.207) | 0.209 (0.185-0.238) | 0.245 (0.214-0.280) | 0.272 (0.235-0.312) | 0.299 (0.255-0.347) | 0.334 (0.280-0.393) | 0.404 (0.332-0.482) | 0.473 (0.383-0.593) |
| 12-hr | 0.078 (0.070-0.088) | 0.098 (0.088-0.110) | 0.124 (0.110-0.139) | 0.144 (0.127-0.162) | 0.170 (0.149-0.193) | 0.191 (0.165-0.218) | 0.211 (0.181-0.245) | 0.232 (0.195-0.272) | 0.260 (0.213-0.311) | 0.285 (0.229-0.346) |
| 24-hr | 0.049 (0.044-0.056) | 0.062 (0.056-0.070) | 0.080 (0.071-0.090) | 0.095 (0.084-0.107) | 0.115 (0.101-0.130) | 0.131 (0.114-0.149) | 0.148 (0.128-0.169) | 0.166 (0.142-0.191) | 0.191 (0.160-0.222) | 0.211 (0.174-0.248) |
| 2-day | 0.030 (0.026-0.034) | 0.038 (0.033-0.043) | 0.049 (0.043-0.056) | 0.059 (0.051-0.067) | 0.072 (0.062-0.082) | 0.083 (0.071-0.095) | 0.094 (0.080-0.109) | 0.106 (0.089-0.124) | 0.124 (0.101-0.147) | 0.138 (0.110-0.166) |
| 3-day | 0.022 (0.019-0.025) | 0.028 (0.024-0.031) | 0.036 (0.032-0.042) | 0.044 (0.038-0.050) | 0.054 (0.047-0.062) | 0.063 (0.054-0.072) | 0.072 (0.061-0.083) | 0.082 (0.068-0.096) | 0.096 (0.078-0.114) | 0.107 (0.085-0.129) |
| 4-day | 0.018 (0.016-0.020) | 0.022 (0.020-0.026) | 0.030 (0.026-0.034) | 0.036 (0.032-0.041) | 0.045 (0.039-0.052) | 0.053 (0.045-0.061) | 0.061 (0.051-0.071) | 0.069 (0.057-0.081) | 0.082 (0.066-0.097) | 0.092 (0.073-0.111) |
| 7-day | 0.012 (0.010-0.014) | 0.015 (0.013-0.018) | 0.020 (0.018-0.024) | 0.025 (0.021-0.029) | 0.031 (0.027-0.036) | 0.036 (0.030-0.042) | 0.042 (0.035-0.049) | 0.048 (0.039-0.057) | 0.056 (0.045-0.068) | 0.063 (0.050-0.078) |
| 10-day | 0.009 (0.008-0.011) | 0.012 (0.011-0.014) | 0.016 (0.014-0.019) | 0.020 (0.017-0.023) | 0.024 (0.021-0.028) | 0.028 (0.024-0.033) | 0.032 (0.027-0.038) | 0.037 (0.030-0.044) | 0.043 (0.034-0.052) | 0.048 (0.038-0.059) |
| 20-day | 0.006 (0.005-0.007) | 0.008 (0.007-0.009) | 0.010 (0.009-0.012) | 0.012 (0.011-0.014) | 0.015 (0.013-0.017) | 0.017 (0.014-0.020) | 0.019 (0.016-0.022) | 0.021 (0.018-0.025) | 0.025 (0.020-0.030) | 0.027 (0.022-0.033) |
| 30-day | 0.005 (0.004-0.005) | 0.006 (0.005-0.007) | 0.008 (0.007-0.009) | 0.010 (0.008-0.011) | 0.012 (0.010-0.013) | 0.013 (0.011-0.015) | 0.015 (0.013-0.017) | 0.016 (0.014-0.019) | 0.019 (0.016-0.023) | 0.021 (0.017-0.025) |
| 45-day | 0.004 (0.003-0.004) | 0.005 (0.004-0.005) | 0.006 (0.006-0.007) | 0.008 (0.007-0.009) | 0.009 (0.008-0.010) | 0.010 (0.009-0.012) | 0.011 (0.010-0.013) | 0.013 (0.011-0.015) | 0.015 (0.012-0.017) | 0.016 (0.013-0.019) |
| 60-day | 0.003 (0.003-0.004) | 0.004 (0.004-0.005) | 0.005 (0.005-0.006) | 0.006 (0.006-0.007) | 0.008 (0.007-0.009) | 0.009 (0.007-0.010) | 0.009 (0.008-0.011) | 0.010 (0.009-0.012) | 0.012 (0.010-0.014) | 0.013 (0.010-0.015) |

¹ Precipitation frequency (PF) estimates in this table are based on frequency analysis of partial duration series (PDS). Numbers in parenthesis are PF estimates at lower and upper bounds of the 90% confidence interval. The probability that precipitation frequency estimates (for a given duration and average recurrence interval) will be greater than the upper bound (or less than the lower bound) is 5%. Estimates at upper bounds are not checked against probable maximum precipitation (PMP) estimates and may be higher than currently valid PMP values. Please refer to NOAA Atlas 14 document for more information.

[Back to Top](#)

PF graphical

PDS-based intensity-duration-frequency (IDF) curves
Latitude: 39.6749°, Longitude: -119.7073°

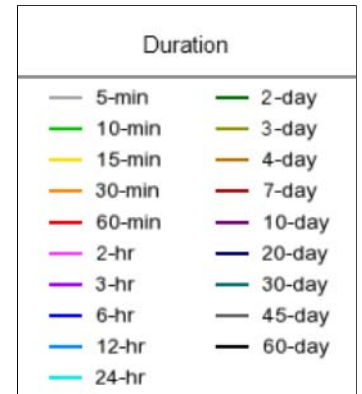
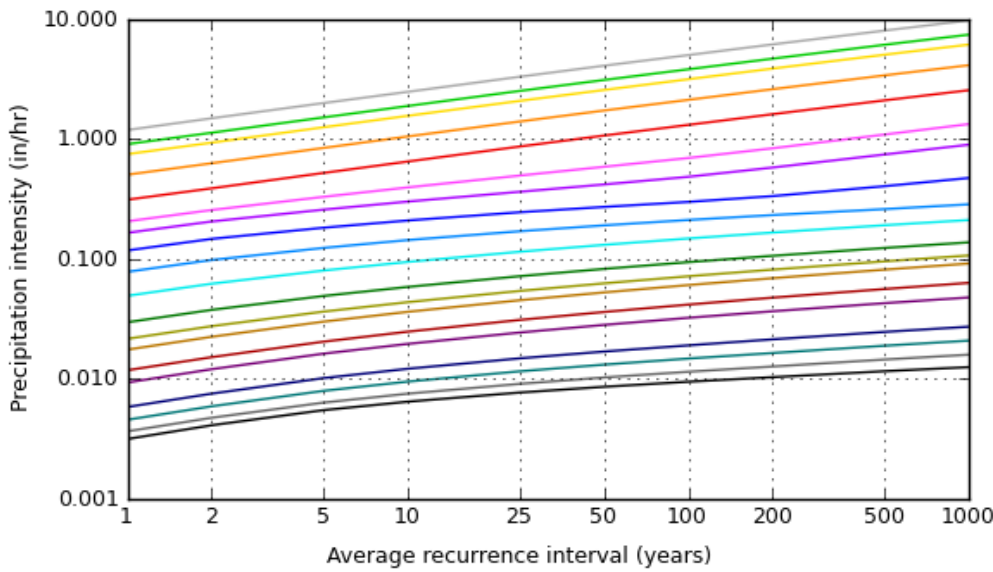
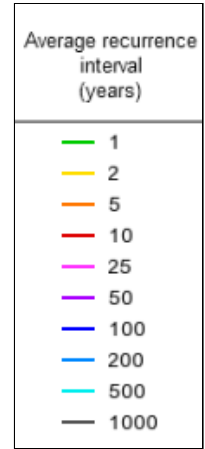
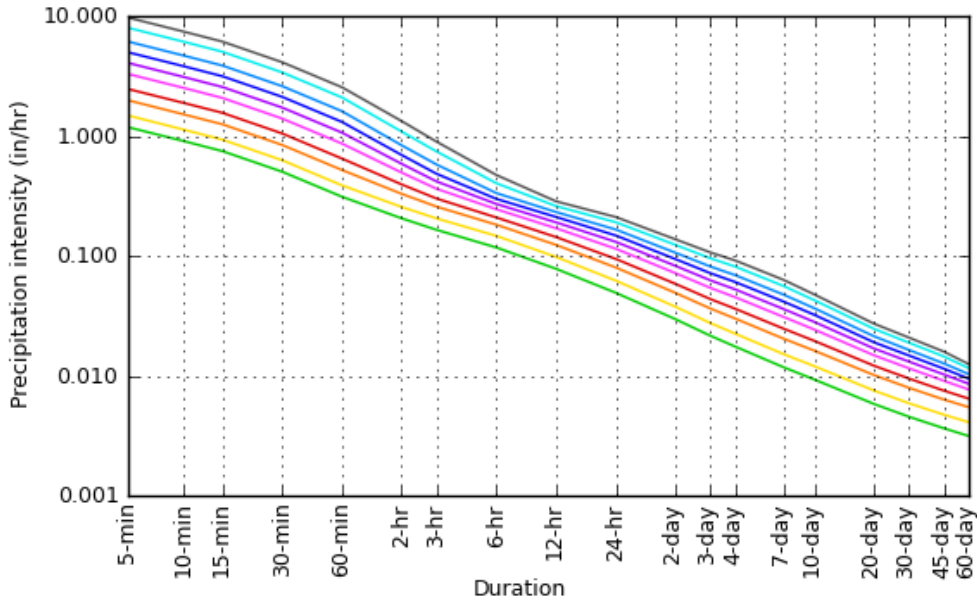

[Back to Top](#)

Maps & aerials

Small scale terrain

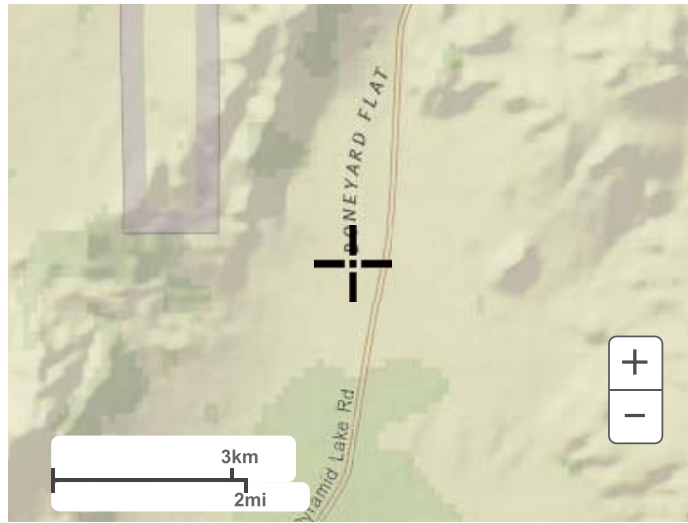

Large scale terrain

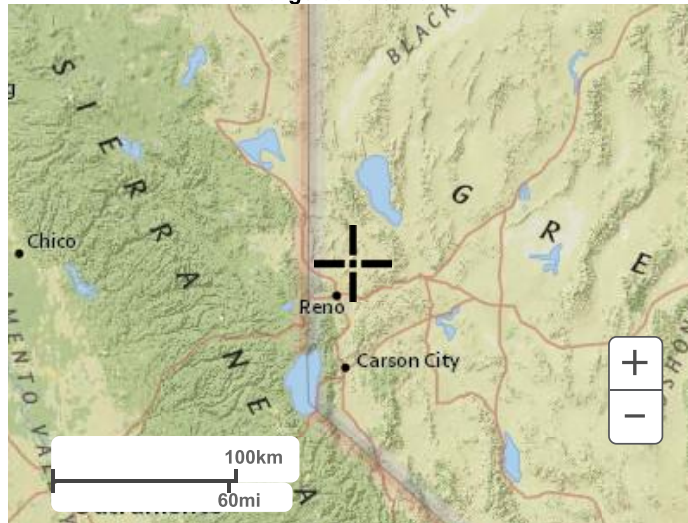

Large scale map

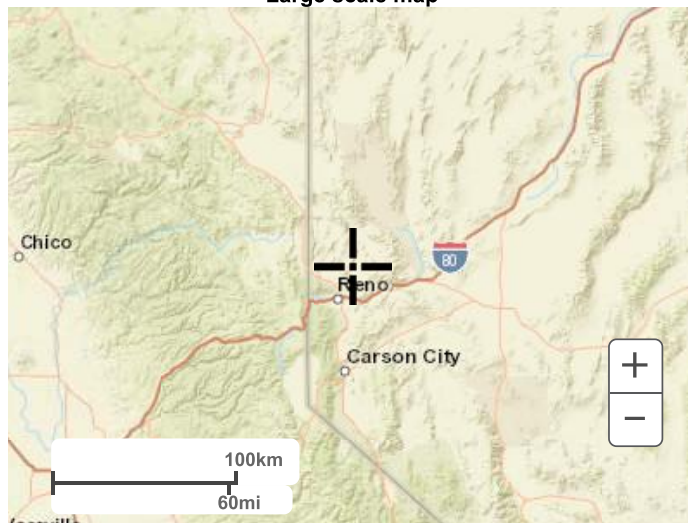

Large scale aerial

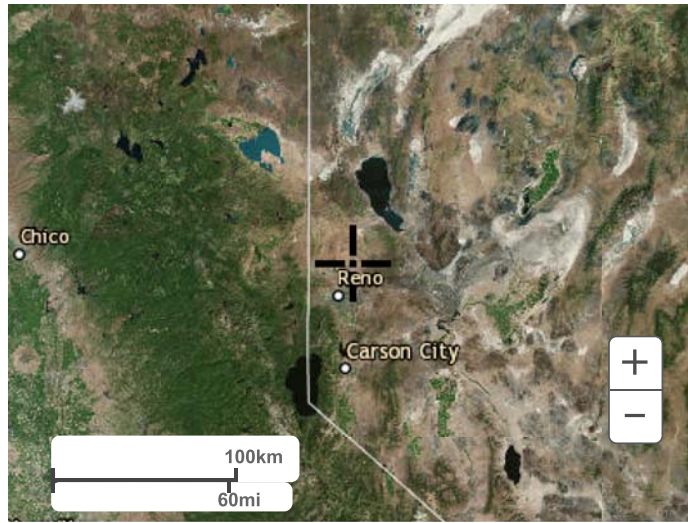

[Back to Top](#)

[US Department of Commerce](#)
[National Oceanic and Atmospheric Administration](#)
[National Weather Service](#)
[National Water Center](#)
1325 East West Highway
Silver Spring, MD 20910
Questions?: HDSC.Questions@noaa.gov

[Disclaimer](#)

**RATIONAL FORMULA METHOD
RUNOFF COEFFICIENTS**

| Land Use or Surface Characteristics | Aver. % Impervious Area | Runoff Coefficients 5-Year (C ₅) | 100-Year (C ₁₀₀) |
|--|----------------------------|--|---------------------------------|
| <u>Business/Commercial:</u> | | | |
| Downtown Areas | 85 | .82 | .85 |
| Neighborhood Areas | 70 | .65 | .80 |
| <u>Residential:</u> (Average Lot Size) | | | |
| 1/8 Acre or Less (Multi-Unit) | 65 | .60 | .78 |
| 1/4 Acre | 38 | .50 | .65 |
| 1/8 Acre | 30 | .45 | .60 |
| 1/2 Acre | 25 | .40 | .55 |
| 1 Acre | 20 | .35 | .50 |
| <u>Industrial:</u> | | | |
| | 72 | .68 | .82 |
| <u>Open Space:</u> (Lawns, Parks, Golf Courses) | | | |
| | 5 | .05 | .30 |
| <u>Undeveloped Areas:</u> | | | |
| Range | 0 | .20 | .50 |
| Forest | 0 | .05 | .30 |
| <u>Streets/Roads:</u> | | | |
| Paved | 100 | .88 | .93 |
| Gravel | 20 | .25 | .50 |
| <u>Drives/Walks:</u> | | | |
| | 95 | .87 | .90 |
| <u>Roof:</u> | | | |
| | 90 | .85 | .87 |

Notes:

- Composite runoff coefficients shown for Residential, Industrial, and Business/Commercial Areas assume irrigated grass landscaping for all pervious areas. For development with landscaping other than irrigated grass, the designer must develop project specific composite runoff coefficients from the surface characteristics presented in this table.

VERSION: April 30, 2009

REFERENCE:

USDCM, DROCOG, 1969
(with modifications)

TABLE
701

WRC ENGINEERING, INC.

RUNOFF CURVE NUMBERS FOR URBAN AREAS¹

Runoff Curve Numbers

| Cover Type and Hydrologic Condition | Aver. % Impervious Area ² | Soil Comp A | Soil Comp B | Soil Comp C | Soil Comp D |
|--|--------------------------------------|-------------|-------------|-------------|-------------|
| <i>Fully developed urban area (vegetation established)</i> | | | | | |
| Open space (lawns, parks, golf courses, cemeteries, etc.) ³ | | | | | |
| Poor condition (grass cover < 50%) | | 68 | 79 | 86 | 89 |
| Fair condition (grass cover 50 to 75%) | | 49 | 69 | 79 | 84 |
| Good condition (grass cover > 75%) | | 39 | 61 | 74 | 80 |
| Impervious areas: | | | | | |
| Paved parking lots, roofs, driveways, etc. (excluding right-of-way) | | 98 | 98 | 98 | 98 |
| Streets and roads: | | | | | |
| Paved; curbs and storm sewers (excluding right-of-way) | | 98 | 98 | 98 | 98 |
| Paved; open ditches (including right-of-way) | | 83 | 89 | 92 | 93 |
| Gravel (including right-of-way) | | 76 | 85 | 89 | 91 |
| Dirt (including right-of-way) | | 72 | 82 | 87 | 89 |
| Western desert urban areas: | | | | | |
| Natural desert landscaping (pervious areas only) ⁴ | | 63 | 77 | 85 | 88 |
| Artificial desert landscaping (impervious weed barrier, desert shrub with 1- to 2-inch sand or gravel mulch and basin borders) | | 96 | 96 | 96 | 96 |
| Urban districts: | | | | | |
| Commercial and business | 85 | 89 | 92 | 94 | 95 |
| Industrial | 72 | 81 | 88 | 91 | 93 |
| Residential districts by average lot size: | | | | | |
| 1/8 acre or less (town houses) | 65 | 77 | 85 | 90 | 92 |
| 1/4 acre | 38 | 61 | 75 | 83 | 87 |
| 1/3 acre | 30 | 57 | 72 | 81 | 86 |
| 1/2 acre | 25 | 54 | 70 | 80 | 85 |
| 1 acre | 20 | 51 | 68 | 79 | 84 |
| 2 acres | 12 | 46 | 65 | 77 | 82 |
| <i>Developing urban areas</i> | | | | | |
| Newly graded areas (pervious only, no vegetation) ⁵ | | 77 | 86 | 91 | 94 |
| Idle lands (CNs are determined using cover types similar to those Table 702 - 3 of 4) | | | | | |

¹Average runoff condition, and $I_a = 0.2S$

²The average percent impervious area shown was used to develop the composite CNs. Other assumptions are as follows: impervious areas are directly connected to the drainage system, impervious areas have a CN of 98, and pervious areas are considered equivalent to open space in good hydrologic condition. CNs for other combinations of conditions may be computed using figure 2-3 or 2-4 in TR-55 (SCS, 1986).

³CNs shown are equivalent to those of pasture. Composite CNs may be computed for other combinations of open space cover type.

⁴Composite CNs for natural desert landscaping should be computed using figure 2-3 or 2-4 in TR-55 (SCS, 1986) based on the impervious area percentage (CN = 98) and the pervious area CN. The pervious area CNs are assumed equivalent to desert shrub in poor hydrologic condition.

⁵Composite CNs to use for the design of temporary measures during grading and construction should be computed using figure 2-3 or 2-4 in TR-55 (SCS, 1986) based on the degree of development (impervious area percentage) and the CNs for the newly graded pervious areas.

VERSION: April 30, 2009

REFERENCE:

210-VI-TR-55, Second Edition, June 1986

TABLE

702

1 of 4

WRC ENGINEERING, INC.

RUNOFF CURVE NUMBERS FOR CULTIVATED AGRICULTURAL LANDS¹

Runoff Curve Numbers

| Cover type | Treatment ² | Hydrologic condition ³ | Soil Comp A | Soil Comp B | Soil Comp C | Soil Comp D |
|--|--------------------------------------|-----------------------------------|-------------|-------------|-------------|-------------|
| Fallow | Bare soil Crop residue cover (CR) | - | 77 | 86 | 91 | 94 |
| | | Poor | 76 | 85 | 90 | 93 |
| | | Good | 74 | 83 | 88 | 90 |
| Row crops | Straight row (SR) | Poor | 72 | 81 | 88 | 91 |
| | | Good | 67 | 78 | 85 | 89 |
| | SR + CR | Poor | 71 | 80 | 87 | 90 |
| | | Good | 64 | 75 | 82 | 85 |
| | Contoured (C) | Poor | 70 | 79 | 84 | 88 |
| | | Good | 65 | 75 | 82 | 86 |
| | C + CR | Poor | 69 | 78 | 83 | 87 |
| | | Good | 64 | 74 | 81 | 85 |
| | Contoured & terraced (C&T) | Poor | 66 | 74 | 80 | 82 |
| | | Good | 62 | 71 | 78 | 81 |
| C&T + CR | Poor | 65 | 73 | 79 | 81 | |
| | Good | 61 | 70 | 77 | 80 | |
| Small grain | SR | Poor | 65 | 76 | 84 | 88 |
| | | Good | 63 | 75 | 83 | 87 |
| | SR + CR | Poor | 64 | 75 | 83 | 86 |
| | | Good | 60 | 72 | 80 | 84 |
| | C | Poor | 63 | 74 | 82 | 85 |
| | | Good | 61 | 73 | 81 | 84 |
| | C + CR | Poor | 62 | 73 | 81 | 84 |
| | | Good | 60 | 72 | 80 | 83 |
| | C&T | Poor | 61 | 72 | 79 | 82 |
| | | Good | 59 | 70 | 78 | 81 |
| C&T + CR | Poor | 60 | 71 | 78 | 81 | |
| | Good | 58 | 69 | 77 | 80 | |
| Close-seeded or broadcast legumes or rotation meadow | SR | Poor | 66 | 77 | 85 | 89 |
| | | Good | 58 | 72 | 81 | 85 |
| | C | Poor | 64 | 75 | 83 | 85 |
| | | Good | 55 | 69 | 78 | 83 |
| | C&T | Poor | 63 | 73 | 80 | 83 |
| | | Good | 51 | 67 | 76 | 80 |

¹Average runoff condition, and $I_a = 0.2S$

²Crop residue cover applies only if residue is on at least 5% of the surface throughout the year.

³Hydrologic condition is based on combination of factors that affect infiltration and runoff, including: (a) density and canopy of vegetative areas, (b) amount of year-round cover, (c) amount of grass or close-seeded legumes in rotations, (d) percent of residue cover on the land surface (good $\geq 20\%$), and (e) degree of surface roughness.

Poor: Factors impair infiltration and tend to increase runoff.

Good: Factors encourage average and better than average infiltration and tend to decrease runoff.

RUNOFF CURVE NUMBERS FOR OTHER AGRICULTURAL LANDS¹

Runoff Curve Numbers

| Cover Type | Hydrologic Condition | Soil Comp A | Soil Comp B | Soil Comp C | Soil Comp D |
|---|----------------------|-----------------|-------------|-------------|-------------|
| Pasture, grassland, or range – continuous forage for grazing ² | Poor | 68 | 79 | 86 | 89 |
| | Fair | 49 | 69 | 79 | 84 |
| | Good | 39 | 61 | 74 | 80 |
| Meadow – continuous grass, protected from grazing and generally mowed for hay | - | 30 | 58 | 71 | 78 |
| Brush – brush-weed-grass mixture with brush the major element ³ | Poor | 48 | 67 | 77 | 83 |
| | Fair | 35 | 56 | 70 | 77 |
| | Good | 30 ⁴ | 48 | 65 | 73 |
| Woods – grass combination (orchard or tree farm) ⁵ | Poor | 57 | 73 | 82 | 86 |
| | Fair | 43 | 65 | 76 | 82 |
| | Good | 32 | 58 | 72 | 79 |
| Woods ⁶ | Poor | 45 | 66 | 77 | 83 |
| | Fair | 36 | 60 | 73 | 79 |
| | Good | 30 ⁴ | 55 | 70 | 77 |
| Farmsteads – buildings, lanes, driveways, and surrounding lots | - | 59 | 74 | 82 | 86 |

¹Average runoff condition, and $I_a = 0.2S$

²*Poor:* < 50% ground cover or heavily grazed with no mulch
Fair: 50 to 75% ground cover and not heavily grazed
Good: > 75% ground cover and lightly or only occasionally grazed

³*Poor:* < 50% ground cover
Fair: 50 to 75% ground cover
Good: >75% ground cover

⁴Actual curve number is less than 30; use CN = 30 for runoff computations.

⁵CNs shown were computed for areas with 50% woods and 50% grass (pasture) cover. Other combinations of conditions may be computed from the CNs for woods and pasture.

⁶*Poor:* Forest litter, small trees, and brush are destroyed by heavy grazing or regular burning.
Fair: Woods are grazed but not burned, and some forest litter covers the soil.
Good: Woods are protected from grazing, and litter and brush adequately cover the soil.

VERSION: April 30, 2009

WRC ENGINEERING, INC.

REFERENCE:

210-VI-TR-55, Second Edition, June 1986

TABLE

702
3 of 4

RUNOFF CURVE NUMBERS FOR ARID AND SEMIARID RANGELANDS¹

Runoff Curve Numbers

| Cover Description | Hydrologic Condition ² | Soil Comp A ³ | Soil Comp B | Soil Comp C | Soil Comp D |
|--|-----------------------------------|--------------------------|-------------|-------------|-------------|
| Herbaceous – mixture of grass, weeds, and low-growing brush, with brush the minor element. | Poor | | 80 | 87 | 93 |
| | Fair | | 71 | 81 | 89 |
| | Good | | 62 | 74 | 85 |
| Oak-aspen – mountain brush mixture of oak brush, aspen, mountain mahogany, bitter brush, maple, and other brush | Poor | | 66 | 74 | 79 |
| | Fair | | 48 | 57 | 63 |
| | Good | | 30 | 41 | 48 |
| Pinyon-juniper – pinyon, juniper, or both; grass understory | Poor | | 75 | 85 | 89 |
| | Fair | | 58 | 73 | 80 |
| | Good | | 41 | 61 | 71 |
| Sagebrush with grass understory | Poor | | 67 | 80 | 85 |
| | Fair | | 51 | 63 | 70 |
| | Good | | 35 | 47 | 55 |
| Desert shrub – major plants include saltbrush, greasewood, creosotebush, blackbrush, bursage, palo verde, mesquite, and cactus | Poor | 63 | 77 | 85 | 88 |
| | Fair | 55 | 72 | 81 | 86 |
| | Good | 49 | 68 | 79 | 84 |

¹Average runoff condition, and $I_a = 0.2S$. For range in humid regions, use Table 702 - 3 of 4.

²*Poor*: < 30% ground cover (litter, grass, and brush overstory)

Fair: 30 to 70% ground cover

Good: > 70% ground cover

³Curve numbers for group A have been developed only for desert shrub.

APPENDIX B

**DRAINAGE BASIN
CALCULATIONS**

APPENDIX C

**BASIN OUTLET
CALCULATIONS**

LUXELOCKER
 EXISTING
 BASIN 1

* * * * * SUMMARY OF RATIONAL METHOD PEAK DISCHARGES * * * * *

$$Q = \text{adj} * C * I * A$$

Where: Q=cfs, C=Weighted Runoff Coefficient, I=in/hour, A=acres
 adj = 'C' adjustment factor for each return frequency

RETURN FREQUENCY = 5 years
 'C' adjustment, k = 1
 Adj. 'C' = Wtd.'C' x 1

| Subarea Descr. | Runoff 'C' | Area acres | Tc (min) | Wtd. 'C' | Adj. 'C' | I in/hr | Total acres | Peak Q (cfs) |
|-------------------|---------------|---------------|-------------|-------------|-------------|------------|----------------|-----------------|
| PERVIOUS | 0.500 | 3.66 | | | | | | |
| | | | 10.00 | 0.500 | 0.500 | 1.510 | 3.66 | 2.76 |

LUXELOCKER
 EXISTING
 BASIN 1

* * * * * SUMMARY OF RATIONAL METHOD PEAK DISCHARGES * * * * *

$$Q = \text{adj} * C * I * A$$

Where: Q=cfs, C=Weighted Runoff Coefficient, I=in/hour, A=acres
 adj = 'C' adjustment factor for each return frequency

RETURN FREQUENCY = 10 years
 'C' adjustment, k = 1
 Adj. 'C' = Wtd.'C' x 1

| Subarea Descr. | Runoff 'C' | Area acres | Tc (min) | Wtd. 'C' | Adj. 'C' | I in/hr | Total acres | Peak Q (cfs) |
|-------------------|---------------|---------------|-------------|-------------|-------------|------------|----------------|-----------------|
| PERVIOUS | 0.500 | 3.66 | | | | | | |
| | | | 10.00 | 0.500 | 0.500 | 1.880 | 3.66 | 3.44 |

LUXELOCKER
EXISTING
BASIN 1

* * * * * SUMMARY OF RATIONAL METHOD PEAK DISCHARGES * * * * *

$$Q = \text{adj} * C * I * A$$

Where: Q=cfs, C=Weighted Runoff Coefficient, I=in/hour, A=acres
adj = 'C' adjustment factor for each return frequency

RETURN FREQUENCY = 25 years
'C' adjustment, k = 1
Adj. 'C' = Wtd.'C' x 1

| Subarea Descr. | Runoff 'C' | Area acres | Tc (min) | Wtd. 'C' | Adj. 'C' | I in/hr | Total acres | Peak Q (cfs) |
|-------------------|---------------|---------------|-------------|-------------|-------------|------------|----------------|-----------------|
| PERVIOUS | 0.500 | 3.66 | | | | | | |
| | | | 10.00 | 0.500 | 0.500 | 2.510 | 3.66 | 4.59 |

LUXELOCKER
EXISTING
BASIN 1

* * * * * SUMMARY OF RATIONAL METHOD PEAK DISCHARGES * * * * *

$$Q = \text{adj} * C * I * A$$

Where: Q=cfs, C=Weighted Runoff Coefficient, I=in/hour, A=acres
adj = 'C' adjustment factor for each return frequency

RETURN FREQUENCY = 50 years
'C' adjustment, k = 1
Adj. 'C' = Wtd.'C' x 1

| Subarea Descr. | Runoff 'C' | Area acres | Tc (min) | Wtd. 'C' | Adj. 'C' | I in/hr | Total acres | Peak Q (cfs) |
|-------------------|---------------|---------------|-------------|-------------|-------------|------------|----------------|-----------------|
| PERVIOUS | 0.500 | 3.66 | | | | | | |
| | | | 10.00 | 0.500 | 0.500 | 3.100 | 3.66 | 5.67 |

LUXELOCKER
 EXISTING
 BASIN 1

* * * * * SUMMARY OF RATIONAL METHOD PEAK DISCHARGES * * * * *

$$Q = \text{adj} * C * I * A$$

Where: Q=cfs, C=Weighted Runoff Coefficient, I=in/hour, A=acres
 adj = 'C' adjustment factor for each return frequency

RETURN FREQUENCY = 100 years
 'C' adjustment, k = 1
 Adj. 'C' = Wtd.'C' x 1

| Subarea Descr. | Runoff 'C' | Area acres | Tc (min) | Wtd. 'C' | Adj. 'C' | I in/hr | Total acres | Peak Q (cfs) |
|-------------------|---------------|---------------|-------------|-------------|-------------|------------|----------------|-----------------|
| PERVIOUS | 0.500 | 3.66 | | | | | | |
| | | | 10.00 | 0.500 | 0.500 | 3.810 | 3.66 | 6.96 |

LUXELOCKER
EXISTING
BASIN 1

* * * * * SUMMARY OF RATIONAL METHOD PEAK DISCHARGES * * * * *

$$Q = \text{adj} * C * I * A$$

Where: Q=cfs, C=Weighted Runoff Coefficient, I=in/hour, A=acres
adj = 'C' adjustment factor for each return frequency

RETURN FREQUENCY = 5 years
'C' adjustment, k = 1
Adj. 'C' = Wtd.'C' x 1

| Subarea Descr. | Runoff 'C' | Area acres | Tc (min) | Wtd. 'C' | Adj. 'C' | I in/hr | Total acres | Peak Q (cfs) |
|-------------------|---------------|---------------|-------------|-------------|-------------|------------|----------------|-----------------|
| PERVIOUS | 0.500 | 3.66 | | | | | | |
| | | | 10.00 | 0.500 | 0.500 | 1.510 | 3.66 | 2.76 |

* * * * * SUMMARY OF RATIONAL METHOD PEAK DISCHARGES * * * * *

$$Q = \text{adj} * C * I * A$$

Where: Q=cfs, C=Weighted Runoff Coefficient, I=in/hour, A=acres
adj = 'C' adjustment factor for each return frequency

RETURN FREQUENCY = 10 years
'C' adjustment, k = 1
Adj. 'C' = Wtd.'C' x 1

| Subarea Descr. | Runoff 'C' | Area acres | Tc (min) | Wtd. 'C' | Adj. 'C' | I in/hr | Total acres | Peak Q (cfs) |
|-------------------|---------------|---------------|-------------|-------------|-------------|------------|----------------|-----------------|
| PERVIOUS | 0.500 | 3.66 | | | | | | |
| | | | 10.00 | 0.500 | 0.500 | 1.880 | 3.66 | 3.44 |

* * * * * SUMMARY OF RATIONAL METHOD PEAK DISCHARGES * * * * *

$$Q = \text{adj} * C * I * A$$

Where: Q=cfs, C=Weighted Runoff Coefficient, I=in/hour, A=acres
adj = 'C' adjustment factor for each return frequency

RETURN FREQUENCY = 25 years
'C' adjustment, k = 1
Adj. 'C' = Wtd.'C' x 1

| Subarea Descr. | Runoff 'C' | Area acres | Tc (min) | Wtd. 'C' | Adj. 'C' | I in/hr | Total acres | Peak Q (cfs) |
|-------------------|---------------|---------------|-------------|-------------|-------------|------------|----------------|-----------------|
| PERVIOUS | 0.500 | 3.66 | | | | | | |
| | | | 10.00 | 0.500 | 0.500 | 2.510 | 3.66 | 4.59 |

* * * * * SUMMARY OF RATIONAL METHOD PEAK DISCHARGES * * * * *

$$Q = \text{adj} * C * I * A$$

Where: Q=cfs, C=Weighted Runoff Coefficient, I=in/hour, A=acres
 adj = 'C' adjustment factor for each return frequency

RETURN FREQUENCY = 50 years
 'C' adjustment, k = 1
 Adj. 'C' = Wtd.'C' x 1

| Subarea Descr. | Runoff 'C' | Area acres | Tc (min) | Wtd. 'C' | Adj. 'C' | I in/hr | Total acres | Peak Q (cfs) |
|-------------------|---------------|---------------|-------------|-------------|-------------|------------|----------------|-----------------|
| PERVIOUS | 0.500 | 3.66 | | | | | | |
| | | | 10.00 | 0.500 | 0.500 | 3.100 | 3.66 | 5.67 |

* * * * * SUMMARY OF RATIONAL METHOD PEAK DISCHARGES * * * * *

$$Q = \text{adj} * C * I * A$$

Where: Q=cfs, C=Weighted Runoff Coefficient, I=in/hour, A=acres
 adj = 'C' adjustment factor for each return frequency

RETURN FREQUENCY = 100 years
 'C' adjustment, k = 1
 Adj. 'C' = Wtd.'C' x 1

| Subarea Descr. | Runoff 'C' | Area acres | Tc (min) | Wtd. 'C' | Adj. 'C' | I in/hr | Total acres | Peak Q (cfs) |
|-------------------|---------------|---------------|-------------|-------------|-------------|------------|----------------|-----------------|
| PERVIOUS | 0.500 | 3.66 | | | | | | |
| | | | 10.00 | 0.500 | 0.500 | 3.810 | 3.66 | 6.96 |

MODIFIED RATIONAL METHOD
 ---- Graphical Summary for Maximum Required Storage ----

First peak outflow point assumed to occur at Tc hydrograph recession leg.

LUXELOCKER
 PROPOSED
 BASIN 1

```

*****
* RETURN FREQUENCY: 5 yr      | Allowable Outflow: 2.76 cfs *
* 'C' Adjustment: 1.000     | Required Storage: 1,239 cu.ft. *
*-----*
* Peak Inflow: 4.53 cfs      | Inflow .HYD stored: NONE STORED *
*****
  
```

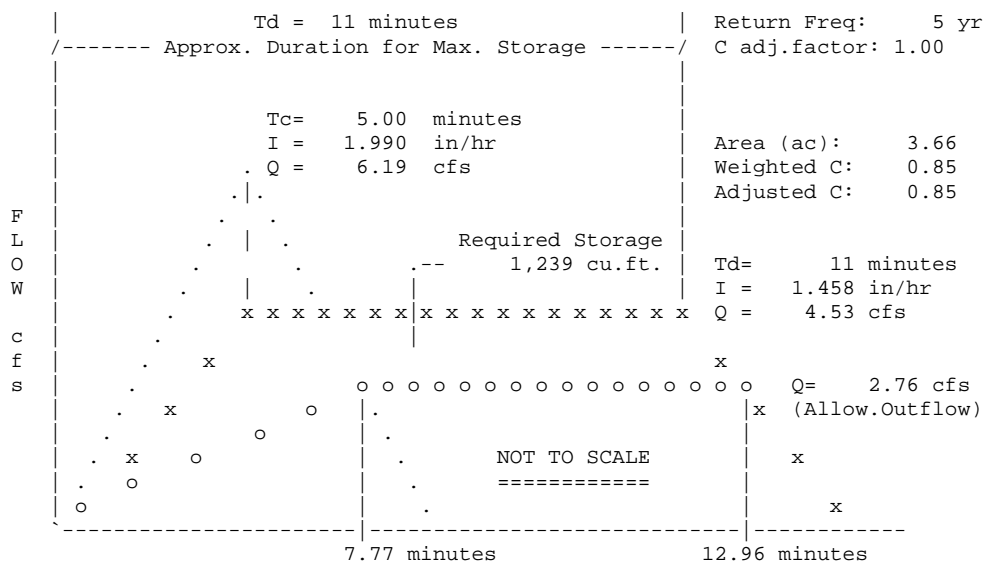

MODIFIED RATIONAL METHOD
 ---- Graphical Summary for Maximum Required Storage ----

First peak outflow point assumed to occur at Tc hydrograph recession leg.

LUXELOCKER
 PROPOSED
 BASIN 1

```

*****
* RETURN FREQUENCY: 10 yr   | Allowable Outflow: 3.44 cfs *
* 'C' Adjustment: 1.000   | Required Storage: 1,541 cu.ft. *
*-----*
* Peak Inflow: 5.45 cfs    | Inflow .HYD stored: NONE STORED *
*****
  
```

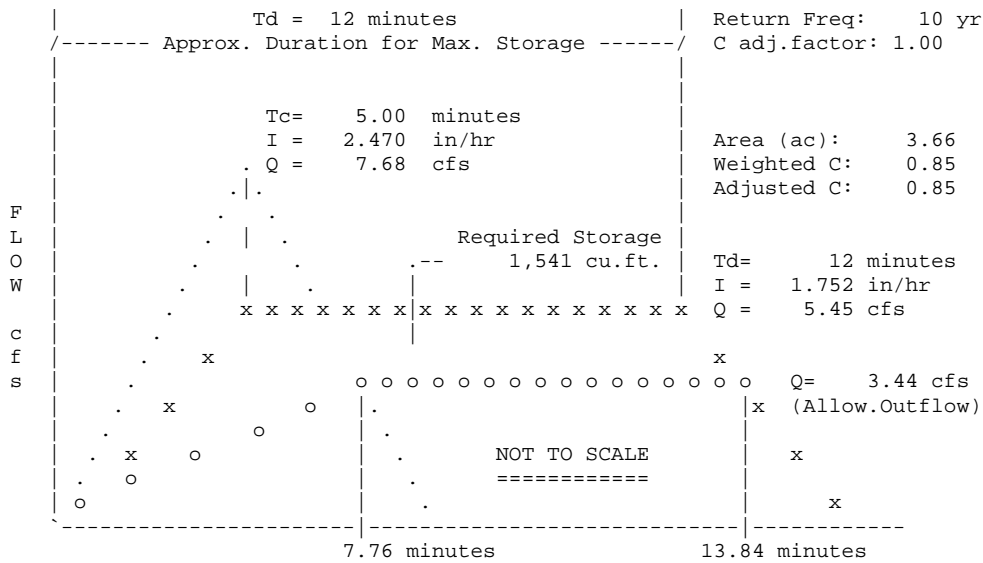

MODIFIED RATIONAL METHOD
 ---- Graphical Summary for Maximum Required Storage ----

First peak outflow point assumed to occur at Tc hydrograph recession leg.

LUXELOCKER
 PROPOSED
 BASIN 1

```
*****
* RETURN FREQUENCY: 50 yr   | Allowable Outflow: 5.67 cfs *
* 'C' Adjustment: 1.000   | Required Storage: 2,538 cu.ft. *
*-----*
* Peak Inflow: 9.31 cfs    | Inflow .HYD stored: NONE STORED *
*****
```

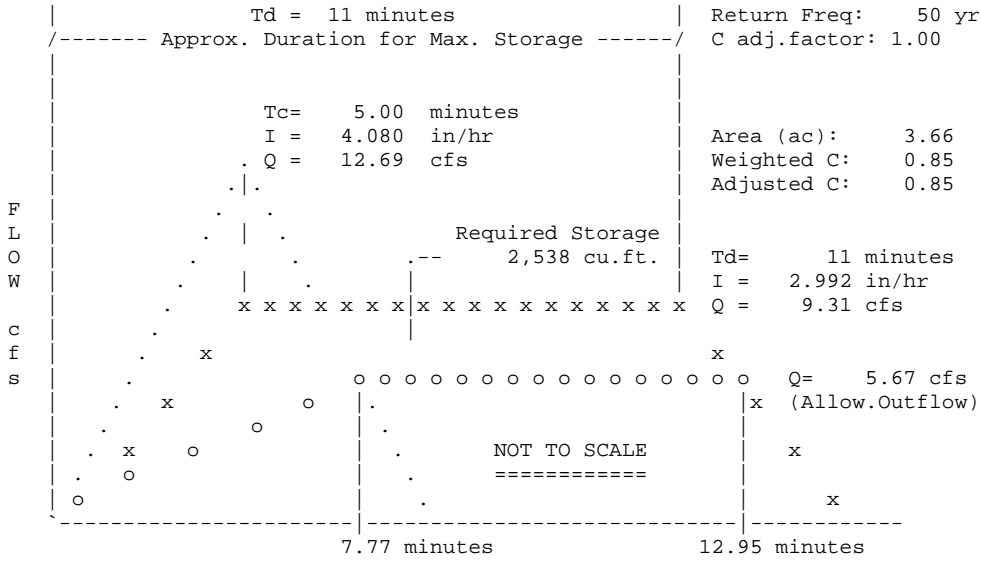

LUXELOCKER
 PROPOSED
 BASIN 1

**** Modified Rational Hydrograph ****
 Weighted C = 0.851 Area= 3.655 acres Tc = 5.00 minutes
 Adjusted C = 0.851 Td= 11.00 min. I= 1.46 in/hr Qp= 4.53 cfs
 RETURN FREQUENCY: 5 year storm Adj.factor = 1.00
 Output file: NONE STORED

HYDROGRAPH FOR MAXIMUM STORAGE
 For the 5 Year Storm

| Time Minutes | Time increment = 1.00 Minutes | | | | | | |
|-----------------|---|------|------|------|------|------|------|
| | Time on left represents time for first Q in each row. | | | | | | |
| 0.00 | 0.00 | 0.91 | 1.81 | 2.72 | 3.63 | 4.53 | 4.53 |
| 7.00 | 4.53 | 4.53 | 4.53 | 4.53 | 4.53 | 3.63 | 2.72 |
| 14.00 | 1.81 | 0.91 | 0.00 | | | | |

LUXELOCKER
 PROPOSED
 BASIN 1

**** Modified Rational Hydrograph ****
 Weighted C = 0.851 Area= 3.655 acres Tc = 5.00 minutes
 Adjusted C = 0.851 Td= 12.00 min. I= 1.75 in/hr Qp= 5.45 cfs
 RETURN FREQUENCY: 10 year storm Adj.factor = 1.00
 Output file: NONE STORED

HYDROGRAPH FOR MAXIMUM STORAGE
 For the 10 Year Storm

| Time Minutes | Time increment = 1.00 Minutes | | | | | | |
|-----------------|---|------|------|------|------|------|------|
| | Time on left represents time for first Q in each row. | | | | | | |
| 0.00 | 0.00 | 1.09 | 2.18 | 3.27 | 4.36 | 5.45 | 5.45 |
| 7.00 | 5.45 | 5.45 | 5.45 | 5.45 | 5.45 | 5.45 | 4.36 |
| 14.00 | 3.27 | 2.18 | 1.09 | 0.00 | | | |

LUXELOCKER
 PROPOSED
 BASIN 1

**** Modified Rational Hydrograph ****
 Weighted C = 0.851 Area= 3.655 acres Tc = 5.00 minutes
 Adjusted C = 0.851 Td= 11.00 min. I= 2.42 in/hr Qp= 7.54 cfs
 RETURN FREQUENCY: 25 year storm Adj.factor = 1.00
 Output file: NONE STORED

HYDROGRAPH FOR MAXIMUM STORAGE
 For the 25 Year Storm

| Time Minutes | Time increment = 1.00 Minutes | | | | | | |
|-----------------|---|------|------|------|------|------|------|
| | Time on left represents time for first Q in each row. | | | | | | |
| 0.00 | 0.00 | 1.51 | 3.02 | 4.52 | 6.03 | 7.54 | 7.54 |
| 7.00 | 7.54 | 7.54 | 7.54 | 7.54 | 7.54 | 6.03 | 4.52 |
| 14.00 | 3.02 | 1.51 | 0.00 | | | | |

LUXELOCKER
 PROPOSED
 BASIN 1

**** Modified Rational Hydrograph ****

Weighted C = 0.851 Area= 3.655 acres Tc = 5.00 minutes
 Adjusted C = 0.851 Td= 11.00 min. I= 2.99 in/hr Qp= 9.31 cfs
 RETURN FREQUENCY: 50 year storm Adj.factor = 1.00
 Output file: NONE STORED

HYDROGRAPH FOR MAXIMUM STORAGE
 For the 50 Year Storm

| Time Minutes | Time increment = 1.00 Minutes | | | | | | |
|-----------------|---|------|------|------|------|------|------|
| | Time on left represents time for first Q in each row. | | | | | | |
| 0.00 | 0.00 | 1.86 | 3.72 | 5.58 | 7.44 | 9.31 | 9.31 |
| 7.00 | 9.31 | 9.31 | 9.31 | 9.31 | 9.31 | 7.44 | 5.58 |
| 14.00 | 3.72 | 1.86 | 0.00 | | | | |

LUXELOCKER
 PROPOSED
 BASIN 1

**** Modified Rational Hydrograph ****

Weighted C = 0.851 Area= 3.655 acres Tc = 5.00 minutes
 Adjusted C = 0.851 Td= 11.00 min. I= 3.68 in/hr Qp= 11.44 cfs
 RETURN FREQUENCY: 100 year storm Adj.factor = 1.00
 Output file: NONE STORED

HYDROGRAPH FOR MAXIMUM STORAGE
 For the 100 Year Storm

| Time Minutes | Time increment = 1.00 Minutes | | | | | | |
|-----------------|---|-------|-------|-------|-------|-------|-------|
| | Time on left represents time for first Q in each row. | | | | | | |
| 0.00 | 0.00 | 2.29 | 4.58 | 6.86 | 9.15 | 11.44 | 11.44 |
| 7.00 | 11.44 | 11.44 | 11.44 | 11.44 | 11.44 | 9.15 | 6.86 |
| 14.00 | 4.58 | 2.29 | 0.00 | | | | |

LUXELOCKER
 PROPOSED
 BASIN 1

* * * * * SUMMARY OF RATIONAL METHOD PEAK DISCHARGES * * * * *

$$Q = \text{adj} * C * I * A$$

Where: Q=cfs, C=Weighted Runoff Coefficient, I=in/hour, A=acres
 adj = 'C' adjustment factor for each return frequency

RETURN FREQUENCY = 5 years
 'C' adjustment, k = 1
 Adj. 'C' = Wtd.'C' x 1

| Subarea Descr. | Runoff 'C' | Area acres | Tc (min) | Wtd. 'C' | Adj. 'C' | I in/hr | Total acres | Peak Q (cfs) |
|-------------------|---------------|---------------|-------------|-------------|-------------|------------|----------------|-----------------|
| PERVIOUS | 0.500 | 0.67 | | | | | | |
| BULLING | 0.930 | 1.43 | | | | | | |
| IMPERVIOUS | 0.930 | 1.55 | | | | | | |
| ----- | | | 5.00 | 0.851 | 0.851 | 1.990 | 3.66 | 6.19 |

LUXELOCKER
 PROPOSED
 BASIN 1

* * * * * SUMMARY OF RATIONAL METHOD PEAK DISCHARGES * * * * *

$$Q = \text{adj} * C * I * A$$

Where: Q=cfs, C=Weighted Runoff Coefficient, I=in/hour, A=acres
 adj = 'C' adjustment factor for each return frequency

RETURN FREQUENCY = 10 years
 'C' adjustment, k = 1
 Adj. 'C' = Wtd.'C' x 1

| Subarea Descr. | Runoff 'C' | Area acres | Tc (min) | Wtd. 'C' | Adj. 'C' | I in/hr | Total acres | Peak Q (cfs) |
|-------------------|---------------|---------------|-------------|-------------|-------------|------------|----------------|-----------------|
| PERVIOUS | 0.500 | 0.67 | | | | | | |
| BULLING | 0.930 | 1.43 | | | | | | |
| IMPERVIOUS | 0.930 | 1.55 | | | | | | |
| ----- | | | 5.00 | 0.851 | 0.851 | 2.470 | 3.66 | 7.68 |

LUXELOCKER
 PROPOSED
 BASIN 1

* * * * * SUMMARY OF RATIONAL METHOD PEAK DISCHARGES * * * * *

$$Q = \text{adj} * C * I * A$$

Where: Q=cfs, C=Weighted Runoff Coefficient, I=in/hour, A=acres
 adj = 'C' adjustment factor for each return frequency

RETURN FREQUENCY = 25 years
 'C' adjustment, k = 1
 Adj. 'C' = Wtd.'C' x 1

| Subarea Descr. | Runoff 'C' | Area acres | Tc (min) | Wtd. 'C' | Adj. 'C' | I in/hr | Total acres | Peak Q (cfs) | |
|-------------------|---------------|---------------|-------------|-------------|-------------|------------|----------------|-----------------|-------|
| PERVIOUS | 0.500 | 0.67 | | | | | | | |
| BULLING | 0.930 | 1.43 | | | | | | | |
| IMPERVIOUS | 0.930 | 1.55 | | | | | | | |
| | | | | 5.00 | 0.851 | 0.851 | 3.300 | 3.66 | 10.26 |

LUXELOCKER
 PROPOSED
 BASIN 1

* * * * * SUMMARY OF RATIONAL METHOD PEAK DISCHARGES * * * * *

$$Q = \text{adj} * C * I * A$$

Where: Q=cfs, C=Weighted Runoff Coefficient, I=in/hour, A=acres
 adj = 'C' adjustment factor for each return frequency

RETURN FREQUENCY = 50 years
 'C' adjustment, k = 1
 Adj. 'C' = Wtd.'C' x 1

| Subarea Descr. | Runoff 'C' | Area acres | Tc (min) | Wtd. 'C' | Adj. 'C' | I in/hr | Total acres | Peak Q (cfs) | |
|-------------------|---------------|---------------|-------------|-------------|-------------|------------|----------------|-----------------|-------|
| PERVIOUS | 0.500 | 0.67 | | | | | | | |
| BULLING | 0.930 | 1.43 | | | | | | | |
| IMPERVIOUS | 0.930 | 1.55 | | | | | | | |
| | | | | 5.00 | 0.851 | 0.851 | 4.080 | 3.66 | 12.69 |

LUXELOCKER
 PROPOSED
 BASIN 1

* * * * * SUMMARY OF RATIONAL METHOD PEAK DISCHARGES * * * * *

$$Q = \text{adj} * C * I * A$$

Where: Q=cfs, C=Weighted Runoff Coefficient, I=in/hour, A=acres
 adj = 'C' adjustment factor for each return frequency

RETURN FREQUENCY = 100 years
 'C' adjustment, k = 1
 Adj. 'C' = Wtd.'C' x 1

| Subarea Descr. | Runoff 'C' | Area acres | Tc (min) | Wtd. 'C' | Adj. 'C' | I in/hr | Total acres | Peak Q (cfs) |
|-------------------|---------------|---------------|-------------|-------------|-------------|------------|----------------|-----------------|
| PERVIOUS | 0.500 | 0.67 | | | | | | |
| BUILING | 0.930 | 1.43 | | | | | | |
| IMPERVIOUS | 0.930 | 1.55 | | | | | | |
| | | | 5.00 | 0.851 | 0.851 | 5.000 | 3.66 | 15.55 |

MODIFIED RATIONAL METHOD
 ---- Summary for Single Storm Frequency ----

First peak outflow point assumed to occur at Tc hydrograph recession leg.

LUXELOCKER
 PROPOSED
 BASIN 1

RETURN FREQUENCY: 25 yr 'C' Adjustment = 1.000 Allowable Q = 4.59 cfs

Hydrograph file: NONE STORED Tc = 5.00 minutes
 ::

| VOLUMES | | | | | | | |
|-----------------------|-----------------|---------------------|------------------|----------------|--------------|--------------------|---------------------|
| Weighted 'C' | Adjusted 'C' | Duration minutes | Intens. in/hr | Areas acres | Qpeak cfs | Inflow (cu.ft.) | Storage (cu.ft.) |
| 0.851 | 0.851 | 5 | 3.300 | 3.66 | 10.26 | 3,079 | 1,702 |
| 0.851 | 0.851 | 10 | 2.510 | 3.66 | 7.81 | 4,684 | 2,027 |
| ***** Storage Maximum | | | | | | | |
| 0.851 | 0.851 | 11 | 2.424 | 3.66 | 7.54 | 4,976 | 2,058 |
| ***** | | | | | | | |
| 0.851 | 0.851 | 15 | 2.080 | 3.66 | 6.47 | 5,822 | 1,872 |
| 0.851 | 0.851 | 20 | 1.853 | 3.66 | 5.76 | 6,917 | 1,649 |
| 0.851 | 0.851 | 30 | 1.400 | 3.66 | 4.35 | Qpeak < Qallow | |

MODIFIED RATIONAL METHOD
 ---- Summary for Single Storm Frequency ----

First peak outflow point assumed to occur at Tc hydrograph recession leg.

LUXELOCKER
 PROPOSED
 BASIN 1

RETURN FREQUENCY: 50 yr 'C' Adjustment = 1.000 Allowable Q = 5.67 cfs

Hydrograph file: NONE STORED Tc = 5.00 minutes
 ::

| VOLUMES | | | | | | | |
|-----------------------|-----------------|---------------------|------------------|----------------|--------------|--------------------|---------------------|
| Weighted 'C' | Adjusted 'C' | Duration minutes | Intens. in/hr | Areas acres | Qpeak cfs | Inflow (cu.ft.) | Storage (cu.ft.) |
| 0.851 | 0.851 | 5 | 4.080 | 3.66 | 12.69 | 3,807 | 2,106 |
| 0.851 | 0.851 | 10 | 3.100 | 3.66 | 9.64 | 5,785 | 2,503 |
| ***** Storage Maximum | | | | | | | |
| 0.851 | 0.851 | 11 | 2.992 | 3.66 | 9.31 | 6,142 | 2,538 |
| ***** | | | | | | | |
| 0.851 | 0.851 | 15 | 2.560 | 3.66 | 7.96 | 7,166 | 2,288 |
| 0.851 | 0.851 | 20 | 2.283 | 3.66 | 7.10 | 8,522 | 2,017 |
| 0.851 | 0.851 | 30 | 1.730 | 3.66 | 5.38 | Qpeak < Qallow | |



**GEOTECHNICAL INVESTIGATION REPORT
LUXE LOCKER – SPANISH SPRINGS
SEC INGENUITY AVE. AND DIGITAL CT.
SPARKS, WASHOE COUNTY, NEVADA**

**PROJECT NO.: RG-19-036
APRIL 19, 2019**

Prepared for:

Tectonics Design Group

Prepared by:

**NOVA GEOTECHNICAL & INSPECTION SERVICES
695 EDISON WAY
RENO, NEVADA 89502
Phone: (775) 856-5566
Fax: (775) 856-6042**

TABLE OF CONTENTS

| | Page No. |
|--|----------|
| 1.0 INTRODUCTION..... | 1 |
| 2.0 PROJECT INFORMATION | 1 |
| 3.0 SITE EXPLORATION | 2 |
| 4.0 SITE CONDITIONS..... | 2 |
| 4.1 Surface | 2 |
| 4.2 Subsurface | 3 |
| 5.0 GEOLOGIC INFORMATION..... | 4 |
| 5.1 Regional Geology | 4 |
| 5.2 Site Geology | 4 |
| 5.3 Faulting and Seismicity..... | 5 |
| 5.4 Tsunami or Seiche..... | 5 |
| 5.5 Slope Stability..... | 5 |
| 5.6 Seismically-Induced Liquefaction..... | 6 |
| 5.7 Flooding | 6 |
| 5.8 Radon..... | 6 |
| 6.0 RECOMMENDATIONS..... | 6 |
| 6.1 General | 6 |
| 6.2 Foundations..... | 7 |
| 6.3 Site Class and Seismic Design Parameters..... | 7 |
| 6.3.1 Site Class..... | 7 |
| 6.3.2 Seismic Design Parameters | 7 |
| 6.4 Lateral Earth Pressures and Retaining Walls..... | 8 |
| 6.4.1 Static Pressures..... | 8 |
| 6.4.2 Seismic Pressures | 9 |
| 6.5 Permanent Slopes | 10 |
| 6.6 Earthwork | 10 |
| 6.6.1 General | 10 |
| 6.6.2 Site Clearing | 10 |
| 6.6.3 Excavation | 11 |
| 6.6.4 Overexcavation | 12 |

| | |
|--|-----------|
| 6.6.5 Fill Materials..... | 12 |
| 6.6.6 Fill Placement and Compaction..... | 13 |
| 6.6.7 Trench Backfill | 14 |
| 6.7 Pavement | 15 |
| 6.8 Drainage and Moisture Protection | 16 |
| 6.9 Concrete Slab on Grade | 17 |
| 6.9.1 Interior Concrete Slabs | 17 |
| 6.9.2 Exterior Concrete Slabs | 17 |
| 6.10 Corrosivity..... | 18 |
| 7.0 OTHER SERVICES | 18 |
| 8.0 CLOSURE | 19 |

APPENDIX

Plate No.

| | |
|--|--------------|
| Site Location Plan | 1 |
| Boring Location Plan..... | 2 |
| Geologic Map..... | 3 |
| Flood Map..... | 4 |
| Boring Logs..... | 5 through 10 |
| Generalized Soil Profile | 11 |
| Explanation of Material Classifications..... | 12 |
| Key to Symbols | 13 |
| Sieve Analysis Test Results..... | 14 and 15 |
| Liquid and Plastic Limits Test Report..... | 16 |
| Consolidation Test Data..... | 17 |
| R-Value Test Report | 18 |
| Direct Shear Test Data | 19 |
| Corrosion Test Data..... | 20 |

**GEOTECHNICAL INVESTIGATION REPORT
LUXE LOCKER – SPANISH SPRINGS
SEC INGENUITY AVE. AND DIGITAL CT.
SPARKS, WASHOE COUNTY, NEVADA**

1.0 INTRODUCTION

This report presents the results of our geotechnical exploration for the proposed storage facility to be located in the Spanish Springs area of Washoe County, Nevada. The site is located at the southeast corner of Ingenuity Avenue and Digital Court. The general location of the site is shown on Figure No. 1, Vicinity Map.

The purpose of our services was to provide information and preliminary geotechnical engineering recommendations relative to:

- Subsurface soil conditions
- General geology and seismicity of the area
- Geologic and seismic hazards
- Site classification and seismic design parameters
- Foundation design and construction
- Drainage and moisture protection
- Retaining wall design and construction
- Concrete slab on grade design and construction
- Earthwork
- Utility trench backfill
- Pavement design and construction
- Corrosion considerations

This report is for the purpose of providing geotechnical engineering and/or testing information and requirements. The scope of our services for this project did not include any environmental assessment or investigation for the presence or absence of hazardous or toxic material in structures, soil, surface water, groundwater or air, below or around this site.

2.0 PROJECT INFORMATION

Our project information is based on a set of preliminary site plans prepared by Consolidated Construction Company, Inc. dated 01/14/2019, and discussions with the design team. The site comprises approximately 3.66 acres and will be used for the construction of five separate self-storage structures. We understand the structures will be one story in height and of prefabricated metal panel construction. We anticipate the structures will be supported by concrete slabs-on-grade

with turned-down (thickened) edges, which will serve as footings. The remainder of the site will be paved with asphalt-concrete (A/C), with appurtenant landscaping.

Maximum dead- plus live-loads for columns and wall loading were not available at the time of writing; however, we anticipate the loading will be normal for this type of construction. We further assume that final grades will generally be at or near existing site grades (plus or minus 4 feet).

3.0 SITE EXPLORATION

The scope of our services for this project included a subsurface exploration program. The subsurface exploration program consisted of drilling six (6) borings to depths ranging from approximately 15.5 to 35.5 feet below existing site grades (BEG). The borings were logged during drilling by our geologist and samples were obtained to aid in material classification and for possible laboratory testing. The approximate locations of the borings are shown on Figure No. 2, *Boring Location Plan*. The locations of the borings were determined in the field by approximating distances from existing features or improvements. Locations were recorded using a hand-held Global Positioning System (GPS) receiver. The location of the borings should be accurate only to the degree implied by the method used. Results of the borings are presented in the Appendix.

4.0 SITE CONDITIONS

4.1 Surface

Site visits were performed on 03/22 and 03/28/2019. The following observations were made during our site visit:

- The project site is located at the southeast corner of Ingenuity Avenue and Digital Court.
- The site comprises Washoe County Assessor's Parcel Numbers (APN's) 530-491-08, -09, and -10.
- According to the Public Land Survey System (PLSS), the project site is located in the NW $\frac{1}{4}$ of the NE $\frac{1}{4}$ of Section 23, Township 21N, Range 20E.
- Based on the USGS Griffith Canyon 7.5-minute topographic map, the site is relatively flat at an elevation of approximately 4,536 feet above mean sea level, based on the NGVD29 vertical datum.
- The project site generally drains to the northwest.
- The project site is currently vacant and unimproved.
- Vegetation at the site consists of sagebrush and cheatgrass.
- The project site is bounded by Digital Court to the west, Ingenuity Avenue to the north, and undeveloped parcels to the east and south.

4.2 Subsurface

No fill was encountered in any of our borings.

In Borings B-1 through B-4, native site soils generally consisted of a surficial layer of sandy silty clay (CL-ML) to depths ranging from 2.5 to 4.5 feet BEG. In Borings B-5 and B-6, we encountered a surficial layer of native clayey sand (SC) to depths of about 3 feet BEG. The CL-ML was dark yellowish brown, medium stiff to stiff, and in a moist condition. The SC was dark yellowish brown, medium dense, and in a moist condition.

Sandy lean clay (CL) was encountered in all borings at depths ranging from approximately 2.8 to 5.3 feet BEG. The layer thickness ranged from about 1 to 4 feet. The clay was dark yellowish brown, medium stiff to hard, dry to moist, and of low plasticity with a plasticity index of about 5 to 8.

Beneath the clay, native soils consisted of alternating layers of clayey sand (SC), and silty sand (SM). The clayey sand was dark yellowish brown, loose to very dense; and in a dry to moist condition. The silty sand was dark yellowish brown, medium dense to very dense, and in a dry condition.

Boulders and cobbles were not encountered in any of our borings and were visible on the surface.

According to mapping by the US Department of Agriculture, Natural Resources Conservation Service (*Soil Survey of Washoe County, Nevada, South Part*), 99.9 percent of the onsite soils consist of Aladshi sandy loam, 2 to 4 percent slopes (Map Unit 971). According to the survey, this unit consists of silty sand (SM) from 0 to 7 inches, sandy lean clay (CL) and/or clayey sand (SC) from 7 to 34 inches, and silty sand from 34 to 60 inches. Percent passing the #200 sieve ranges from 25 to 35 from 0 to 7 inches, 45 to 60 from 7 to 34 inches, and 15 to 30 from 34 to 60 inches. Liquid limits range from 20 to 25 from 0 to 7 inches, 25 to 35 from 7 to 34 inches, and 20 to 25 from 34 to 60 inches. Plasticity indexes range from non-plastic (NP) from 0 to 7 inches, 10 to 20 from 7 to 34 inches, and NP to 5 from 34 to 60 inches.

This soil is generally classified as hydrologic Group C. These are soils having a slow infiltration rate when thoroughly wet. These consist chiefly of soils having a layer that impedes the downward movement of water or soils of moderately fine texture or fine texture. These soils have a slow rate of water transmission

Consolidation tests indicate some on-site clayey sand soils become considerably weaker and more compressible upon wetting.

R-Value testing indicates the upper soil has an R-value of 13. This indicates that the subgrade soils do not have good support characteristics.

Corrosion test results indicate that the soils are considered minimally corrosive to buried conduit and not deleterious to normally formulated concrete.

Groundwater was not encountered within the depths explored.

For more detailed information, please refer to the boring logs, ReMi results, and laboratory test results presented in the Appendix.

5.0 GEOLOGIC INFORMATION

5.1 Regional Geology

The site is located in the central portion of Spanish Springs Valley, a fault-bounded graben. An unnamed ridge composed primarily of granitic rock bounds the valley to the west. To the east the valley is bordered by the Pah Rah Range, which is composed of granite and gabbro intrusions, ash flow tuffs, and andesitic and basaltic flows. The entire valley and accompanying ridges drain to the south. The southern 1/3 of the valley is poorly-drained and numerous small ponds have formed resulting, in part, from the termination of the Orr Ditch. The North Truckee Drain (exiting the valley to the southeast) partially drains the area.

5.2 Site Geology

Based on mapping completed by Larry J. Garside and Fred L. Nials (*Preliminary Geologic Map of the Griffith Canyon Quadrangle, Nevada*, Nevada Bureau of Mines and Geology, dated 1998), the materials underlying the site consist of Quaternary-age alluvium (**Qa**) underlain by older Quaternary-age playa deposits (**Qp**). The alluvium consists of “Holocene alluvium, restricted to valley bottoms and localized portions of some fan surfaces. Unconsolidated, predominantly arkosic, sand and gravelly sand deposited as sheetwash and wash alluvium in Holocene to modern channels or as broad, low-gradient alluvial plains. Locally contains abundant medium sand reworked from older aeolian deposits (e.g., at the mouth of unnamed canyon in NW $\frac{1}{4}$, NW $\frac{1}{4}$ Sec. 3, T21N, R20E). No soil development except on very localized Holocene terraces (not mapped), where weak 10-15 cm gray-brown A horizon is present in some places. Includes undifferentiated alluvial fan and colluvial deposits in upland areas.”

The playa deposits consist of “light-brown, moderately well-sorted, sandy silt and clay. Present only in limited area of Boneyard Flat in Spanish Springs Valley. Mostly obscured by modern wash deposits associated with gravel quarrying activities in the area.”

5.3 Faulting and Seismicity

Faulting

The United States Geological Survey (USGS) publishes a Quaternary fault and fold database for use with Google Earth. This database allows the user to view possible faults at or near a location. The database and the referenced geologic map show the undifferentiated Quaternary Spanish Springs Valley fault located approximately 6,200 feet west of the site. This fault trends in a roughly north-northeast to south-southwest direction and does not traverse the project site. Another fault associated with an “unnamed fault zone east of Reno” terminates approximately 3,400 feet south southeast of the project site. This fault trends in an NNW-SSE direction. Due to their orientation and distance from the site, it is our opinion that these faults need no further investigation.

Seismicity

No known fault traces are mapped as crossing the site. Active faults capable of generating large magnitude earthquakes have been identified within the region. The project site is located in the Basin and Range Physiographic Province which is structurally characterized by high-angle extensional normal faults. Strong ground shaking associated with earthquakes should be expected to occur during the life of the project.

Literature prepared by A. Ryall and B. M. Douglas (NBMG, *Regional Seismicity*, Reno Folio, 1976) indicates that earthquake recurrence curves predict a return period of 70 to 80 years for an earthquake of Magnitude 7.0 or greater within 62 miles of the Reno area. They also calculate that, on average, an earthquake of Magnitude 5.3 to 5.4 would be expected to occur within 20 miles of Reno approximately once in 30 years, would have a maximum bedrock acceleration of 0.12 to 0.19g, and would involve about 6 seconds of strong shaking. The expected return period of rock accelerations greater than 0.5g at an average site in western Nevada associated with an earthquake of magnitude greater than 7.0 is on the order of 2000 years.

5.4 Tsunami or Seiche

A tsunami, or a seiche, is a great wave produced by an earthquake or by volcanic activity. A seiche is an oscillating tsunami that develops in enclosed bodies of water, like lakes or bays. The oscillation is typically triggered by variations in atmospheric pressure, wind, tidal currents, earthquakes, or a combination of these factors. Depending on the geometry of the basin, the oscillation continues for some time after the triggering event has ended. There are no large bodies of water near the project site; therefore, the potential for tsunamis or seiches to impact the site is considered nonexistent.

5.5 Slope Stability

No slopes are anticipated to be constructed as part of site development. Moreover, due to the relatively level nature of the site and the compact density state of the underlying materials, we do not believe that slumping and/or ground disturbances will impact the site during construction

activities. However, the stability of on-site materials should be evaluated prior to any excavation or trenching. Shoring may be required.

5.6 Seismically-Induced Liquefaction

Liquefaction is defined as the condition when saturated, loose, finer-grained sand-type soils lose their support capabilities because of excessive pore water pressure which develops during a seismic event. Due to the dense, firm, cohesive nature of the subsurface soils and depth to groundwater, liquefaction is not likely to occur at the site during a design seismic event..

5.7 Flooding

Based on studies completed by the Federal Emergency Management Agency (FEMA), community panel number 32031C2865G, effective 03-16-2009, the site is within flood hazard zone X (unshaded). These are areas of minimal flood hazard. A copy of the flood hazard map is included in plate 4, *Flood Map*.

5.8 Radon

Radon, a colorless, odorless, radioactive gas derived from the natural decay of uranium. It is found in nearly all rocks and soils. The Environmental Protection Agency (EPA) suggests that remedial action be taken to reduce radon in any structure with average indoor radon level of 4.0 pCi/L or more. Based on studies completed by the Nevada Bureau of Mines and Geology in cooperation with the Nevada Division of Health and the U.S. Environmental Protection Agency (Radon in Nevada, Nevada Bureau of Mines and Geology, Bulletin 108, 1994), the project site is considered to be in an area where average indoor radon concentrations could exceed 4.0 pCi/L. We recommend testing the site for radon. Our office can be of assistance if radon testing is desired.

6.0 RECOMMENDATIONS

6.1 General

Our recommendations are based on the assumption that the soil conditions are similar to those disclosed by the explorations. If variations are noted during construction or if changes are made in site plan, structural loading, foundation type or floor level, we should be notified so we can supplement our recommendations, as applicable.

The owner must recognize that this site has inherent risks to development due to the loose nature of the upper native site soils, and the clayey and possibly expansive nature of the on-site soils. The clays have the potential to undergo relatively large movements due to increases in moisture content. Foundation designs presented in this report will reflect the potential for mildly expansive clays. For

these recommendations to be effective the recommendations presented in the Drainage and Moisture Protection section of the report must be strictly adhered to. **In addition, the clays should not be used as fill in structure areas.**

6.2 Foundations

If the grading recommendations presented in the Earthwork section of this report are complied with the proposed structures and any block walls or retaining walls may be supported by conventional shallow foundations. Foundations should be established on properly compacted fill.

Foundations should be at least 12 inches wide and the bottom of the foundations should be established at least 24 inches below the lowest adjacent final compacted subgrade (generally pad grade). Foundations established as recommended, may be designed to impose a net dead- plus live-load pressure of 2,000 pounds per square foot (psf). A one-third increase may be used for wind or seismic loads.

Settlement of the proposed structures, supported as recommended, should be within acceptable limits (less than 1 inch). Differential settlement should be less than ½-inch. However, it should be understood that if expansive soils beneath foundations experience an increase in moisture, expansion/heave and/or settlement could occur and cause additional movement of a structure. Therefore, it is important that recommendations presented in the Drainage and Moisture Protection section of this report be adhered to.

6.3 Site Class and Seismic Design Parameters

6.3.1 Site Class

The 2012 International Building Code (IBC) requires assuming a default Site Class of D for seismic design when soil conditions for the top 100 feet are not known in sufficient detail for determination in accordance with Table 20.3-1 of ASCE Standard 7.

The Site Class for the subject project site was estimated using geophysical exploration (ReMi) data and generalized soil characteristics given in Table 20.3-1 of ASCE Standard 7. Based on the results of our geophysical exploration, a Site Class ___ may be used for determining seismic design criteria. Results of the ReMi survey and analysis are presented in the Appendix.

6.3.2 Seismic Design Parameters

We obtained the site seismic design parameters using the ATC Hazards by Location website. This application is a third-party graphical user interface (GUI) utilizing the USGS seismic design maps, and is used for determining seismic design values according to ASCE/SEI 7-10 and the

2012/2015 International Building Code. Design parameters are presented in the following Table 1:

| TABLE 1 | |
|--|-----------------|
| 2012/2015 IBC SEISMIC DESIGN PARAMETERS | |
| Description | Value |
| Latitude | 39.676845 deg |
| Longitude | -119.702624 deg |
| Site Class | D |
| Risk Category | II |
| Short-Period (0.2 sec) Spectral Response, S_S | 1.405 g |
| Long-Period (1.0 sec) Spectral Response, S_1 | 0.475 g |
| Short-Period (0.2 sec) Site Coefficient, F_A | 1.000 |
| Long-Period (1.0 sec) Site Coefficient, F_V | 1.525 |
| Short (0.2 sec) MCE Spectral Response, S_{MS} | 1.405 g |
| Long (1.0 sec) MCE Spectral Response, S_{M1} | 0.724 g |
| Short (0.2 sec) Design Spectral Response, S_{DS} | 0.936 g |
| Long (1.0 sec) Design Spectral Response, S_{D1} | 0.483 g |
| PGA | 0.532 g |
| Seismic Design Category | D |

6.4 Lateral Earth Pressures and Retaining Walls

6.4.1 Static Pressures

For soils above any free water surface, with level backfill and no surcharge loads, we recommend the following equivalent fluid pressures and coefficient of friction:

- Active30 pcf
- At-Rest.....50 pcf
- Passive300 pcf
- Coefficient of Friction0.45
- Unit Weight of Backfill.....130 pcf

Notes:

1. Active pressure assumes unrestrained (cantilever) wall and assumes no loading from heavy compaction equipment.
2. Passive pressure should not exceed a maximum of 4000 psf. A one-third increase may be used for wind or seismic loads.
3. The passive pressure and the frictional resistance of the soils may be combined without reduction in determining the total lateral resistance.

6.4.2 Seismic Pressures

If required by the 2018 IBC, the lateral seismic pressure acting on an unrestrained wall can be estimated by the following equation, where the dynamic (seismic) lateral thrust, ΔP_{AE} , per linear foot of wall may be determined as follows:

$$\Delta P_{AE} = \frac{3}{8}(k_h)H^2\gamma$$

- k_h is equal to $S_{DS}/2.5$
- H is the height of the wall in feet
- γ is equal to the unit weight of the backfill material, in pcf

The resultant dynamic force acts at a distance of $0.6H$ above the base of the wall. This equation applies to level backfill and walls that retain no more than 15 feet.

Where the design includes unrestrained walls, above any free water, with level backfill and no surcharge loads, we recommend the wall be designed to resist an earth pressure with the distribution shown below:

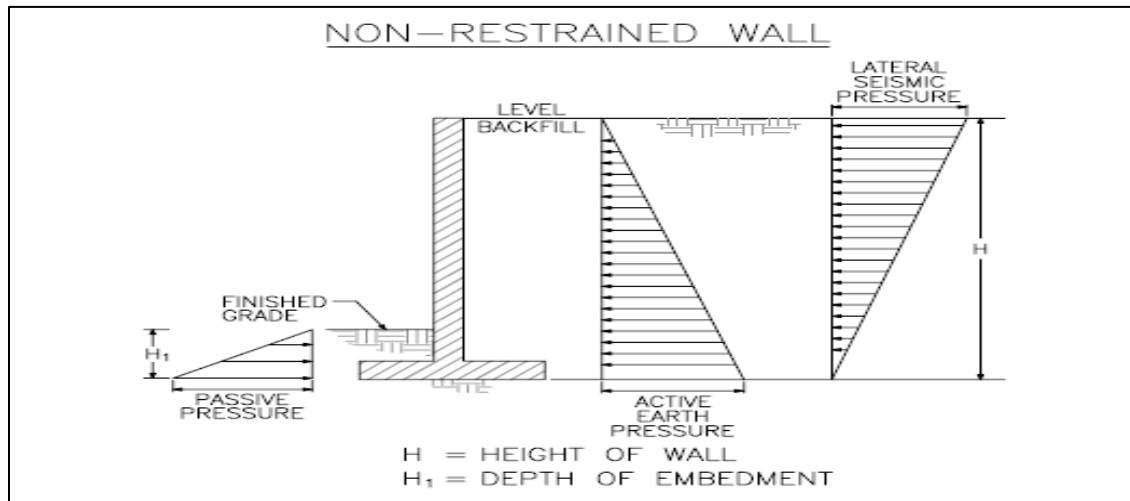

Any surcharge from adjacent loadings should be added to the retaining wall pressures using a factor of 0.30. As indicated, the aforementioned pressures assume that there will be no build-up of hydrostatic pressure. Therefore, if walls will be subject to saturated conditions, we recommend weep holes (if practical) and a wall drainage system. The wall drainage may consist of a minimum of 2 cubic feet of drain rock per foot of length of retaining wall wrapped in filter fabric, Mirafi 140N or equivalent, placed at the base of the wall and discharge to an appropriate outlet. Drain rock should consist of $\frac{3}{4}$ -inch Drain Backfill as per Section 704.03.02 of the USS. The structural fill immediately behind retaining walls (6 to 12 inches) should be granular and free draining. The upper 2 feet of

backfill should consist of compacted native soils. As an option, a prefabricated drain may be used behind walls. The wall drainage system is an integral part of the retaining wall design. The retaining wall designer is ultimately responsible for the retaining wall design and shall ensure that the above recommended drainage system is compatible with the design of the wall or select a different drainage system at their discretion. All walls below grade should be waterproofed or at least dampproofed.

Fill against foundations, grade beams and retaining walls should be properly placed and compacted. Backfill should be mechanically compacted in layers (6 to 8 inches maximum thickness); flooding should not be permitted. Backfill within 2 feet of the back of retaining walls should be compacted to at least 90 percent of the maximum dry density obtainable by the ASTM D1557 method. Backfill outside the 2-foot zone should be compacted as outlined in the Fill Placement and Compaction section of this report. Care should be taken when placing backfill so as not to damage the walls. Compaction of each lift adjacent to walls should be accomplished with hand-operated tampers or other lightweight compactors. Overcompaction may cause excessive lateral earth pressures which could result in wall movements. Retaining walls should not be backfilled until the concrete or masonry has reached an adequate strength as specified by the wall designer.

6.5 Permanent Slopes

Based on information provided by the client, no permanent slopes are planned.

6.6 Earthwork

6.6.1 General

- All earthwork should be performed in accordance with the guidelines presented in Chapter 18 of the 2012 IBC and the Southern Nevada Amendments to the 2012 IBC, except where specific recommendations are presented in this report. It is recommended that contractors perform their own reconnaissance of the site. If the contractors have any questions regarding site conditions, site preparation or recommendations in this report, they should contact a representative of NOVA Geotechnical & Inspection Services.

6.6.2 Site Clearing

- Strip and remove existing vegetation, debris, and other deleterious materials from proposed building areas, adjacent walks and slabs, and in areas to be paved. Excavations should extend at least 5 feet beyond the areas to be improved in plan view. Uncontrolled fill is defined as any existing fill that was not properly placed, observed and tested.
- All exposed surfaces should be free of mounds and depressions which could prevent uniform compaction.

- If unexpected fills or abandoned structures/improvements are encountered during site clearing, such features should be removed and the excavation thoroughly cleaned and backfilled. All excavations should be observed by the geotechnical engineer prior to backfill placement.
- Demolition of existing structures/improvements should include removal of any foundation system and utilities. Any excavations as a result of demolition and removal should be properly filled.
- All materials derived from the demolition of existing structures/improvements should be removed from the site, and not be allowed for use in any fills. In some cases, existing pavements, if properly broken up, can be used in required fills. The geotechnical engineer should determine the suitability for use based on conditions in the field.

6.6.3 Excavation

- It is anticipated that excavation of the on-site native soils for the proposed project can be accomplished with conventional earthmoving equipment.
- Contractors, especially those excavating for utilities, should satisfy themselves as to the hardness of materials and equipment required.
- Depending on the depth of excavation, the on-site exposed clayey soils may contain high water contents and pump, become unstable or unworkable. Workability may be improved by scarifying and drying. Overexcavation and/or stabilization may be necessary. Stabilization can be accomplished by working in oversize material (usually 3 to 6 inches in size and angular or subangular in shape) until a stable base is achieved. Use of geogrids could also be considered as a stabilization technique. Lightweight excavation equipment may be required to reduce subgrade pumping.
- Depending upon the depth of excavation and seasonal conditions, groundwater may be encountered in excavations on the site. Pumping from sumps may be utilized to control small amounts of water within excavations. Well points may be required for significant groundwater flow, or where excavations penetrate groundwater to a significant depth. Any dewatering is the responsibility of the contractor. In addition, the exposed on-site clayey soils may contain high water contents and pump, become unstable or unworkable. Workability may be improved by scarifying and drying. Overexcavation and/or stabilization may be necessary. Stabilization can be accomplished by working in oversize material (usually 3 to 6 inches in size and angular or subangular in shape) until a stable base is achieved. Use of geogrids could also be considered as a stabilization technique. Lightweight excavation equipment may be required to reduce subgrade pumping.

- Temporary un-surcharged construction excavations should be sloped or shored. Slopes should not be steeper than 3:1. Slopes may need to be flattened depending on conditions exposed during construction. Exposed slopes should be kept moist (but not saturated) during construction. If there is not enough space for sloped excavations, shoring should be used. Traffic and surcharge loads should be kept back at least 10 feet from the top of the excavation.
- Excavation, trenching and shoring should be conducted in accordance with the U.S. Department of Labor Occupational Safety and Health Administration's (OSHA) Excavation and Trenching Standard, Title 29 of the Code of Federal Regulation (CFR), Part 1926.650. Safety of construction personnel is the responsibility of the contractor.

6.6.4 Overexcavation

- Based upon the results of our exploration, the upper 3 or 4 feet of natural soil was generally loose and/or clayey in consistency. As previously mentioned, these soils would not be suitable for support of foundations, floor slabs or paving in their present state. We recommend overexcavating and recompacting 1 foot below bottom-of-footings and below final grades.
- Within the entire building areas and 5 feet beyond and 2 feet beyond block and retaining walls, overexcavate and recompact the upper 1 foot of natural soils or natural soils within 1 foot below the bottom of foundations, whichever is lower. In areas to be paved (including adjoining sidewalks, patios and other concrete slabs) and at least 2 feet beyond in plan view, it will only be necessary to overexcavate and recompact 1 foot of natural soils below existing grade or final subgrade, whichever is lower.
- It is important that the lower portion (at least 6 inches in structure areas and six inches in paved areas) of the fill material placed in the overexcavated area consist of the on-site fine-grained soils that are excavated. This layer will act as a relatively impermeable blanket and help keep moisture from reaching any porous materials below. If porous soils below the compacted fill blanket experience an increase in moisture, additional settlement may occur.
- It is important that the fill material placed in the overexcavated area consist of material having an expansion potential of less than 4 percent and have at least 20 percent of the material passing the No. 200 sieve.

6.6.5 Fill Materials

- On-site soils, meeting the following criteria, may be used in required fills:
 - the majority of the material (85 to 90 percent) is 6 inches or less in maximum dimension.
 - the minus 6-inch material is comprised of at least 40 percent by weight of material finer than $\frac{3}{4}$ -inch in size.
 - the material is free of almost all debris and organic matter.

- In general, material greater than 12 inches in diameter should not be used in fills within 5 feet below the bottom of the footing within building pad areas.
- Fill containing material greater than 6 inches in diameter should not be used in any utility trenches, behind retaining walls or against foundations or grade beams.
- Imported material should be compatible with on-site soils in addition to being suitable for its intended use. All imported materials should be approved, by the geotechnical firm providing testing during construction, prior to importing. In general, imported soils should be granular and should conform to the following:

| <u>Gradation (ASTM C136):</u> | <u>Percent Finer by Dry Weight:</u> |
|-------------------------------|-------------------------------------|
| 6-inch..... | 100 |
| ¾-inch..... | 70-100 |
| No. 4 Sieve..... | 50-100 |
| No. 200 Sieve..... | 15-40 |
| | |
| • Liquid Limit | 40 maximum |
| • Plasticity Index..... | 15 maximum |
| • Expansion Index..... | 36 maximum |
| • Sulfate Content (%)..... | 0.1 maximum |

- Select free draining granular materials should be used as backfill immediately behind retaining walls (6 to 12 inches). As an option, a prefabricated drain may be used and should be installed in accordance with the manufacturer’s recommendations.

6.6.6 Fill Placement and Compaction

- After performing required excavations, the exposed soils should be carefully observed to verify removal of all unsuitable deposits. Exposed soils should then be scarified to a depth of 6 inches, watered as necessary, and compacted as recommended.
- Fill materials should be placed on a horizontal plane unless otherwise accepted by the geotechnical engineer.
- Where the slope ratio of the original ground is steeper than 5 horizontal to 1 vertical, the slope should be benched to create near-level areas for the placement of fill. The maximum allowable height of the bench is 3 feet. Bench excavation should be continued to the top of the existing slope in structural fill areas or the daylight (cut/fill) contact.
- All required fill should be placed in loose lifts generally not over 8 to 12 inches in thickness.

- All required fill should be placed in loose lifts. The lift thickness will depend on the size of the material present. Based on the size of the material encountered, lifts will range from 8 to 18 inches in thickness.
- Oversize material greater than 12 inches in size should not be allowed within 5 feet of final grade or 5 feet below foundations in building pad areas. In areas outside of the building pad, the owner should determine how much removal is practical and acceptable.
- Materials should be compacted to a minimum 90 percent relative compaction as determined by ASTM D1557. Aggregate base should be compacted to a minimum 95 percent relative compaction.
- Clayey soils should not be allowed to dry out such that cracking occurs during or after grading. Sufficient moisture contents should be maintained, to prevent cracking, at least until foundations, floor slabs, flatwork and pavements are constructed. Any significantly dried or cracked soils could be wetted until they reach acceptable moisture contents or they could be excavated and replaced with acceptable properly compacted fill.
- Structural fill should be observed and tested as necessary to determine compliance with the compaction requirements presented in this report. In general, one compaction test should be performed for approximately every 500 cubic yards of fill, one for one foot of fill placed, or change in material.

6.6.7 Trench Backfill

The Earthwork Contractor must comply with the "Safety and Health Regulations for Construction" as directed by the Occupational Safety and Health Act (OSHA Standards, Volume III, Part 1926, Subpart P) while excavating and backfilling. The Earthwork Contractor is also responsible for providing a competent person, as defined by OSHA standards, to ensure excavation safety.

Pipe bedding and trench backfill materials should be moisture conditioned to slightly over optimum and compacted to 90 percent relative compaction, or local requirements, based on the maximum dry density determined by ASTM D1557. The upper 12 inches of trench backfill within asphalt or concrete paved areas should be compacted to a minimum 95 percent relative compaction as determined by ASTM D1557. The thickness of all lifts will be restricted to a maximum of 8 inches (loose) and individually tested unless the Earthwork Contractor can demonstrate their ability to uniformly achieve the required compaction for the entire layer of material placed.

Surface stormwater runoff should be prevented from infiltrating into utility trenches. As such, lean concrete should be used for manhole collars to minimize infiltration at these points.

For corrosion protection, where steel and/or metal pipes are proposed, we recommend that the Contractor follow the pipe manufacturer’s recommendation regarding corrosion protection.

6.7 Pavement

The pavement area subgrade should be properly prepared as outlined in the Earthwork section of this report before placing any asphalt or base materials. Due to the low R-Value of 13 and fine-grained nature of the upper site soils, in pavement areas a layer of geofabric should be placed on top of the prepared subgrade, and beneath the aggregate base (A/B). This will help prevent fines from contaminating the A/B. Proper drainage of the paved areas should be provided to increase the pavement life. In addition, pavements must be maintained for durability and integrity during their life. Therefore, periodic seal coating, crack sealing, and/or patching may be required.

Based on the soil classifications and assumed traffic volumes, we recommend the following minimum pavement sections for on-site paved areas:

| ASPHALT CONCRETE PAVEMENT SECTIONS | | |
|--|-------------------------|---|
| TRAFFIC AREA | A/C (Inches) | TYPE II BASE COURSE (Inches) |
| Automobile Parking | 4 | 8 |
| Main Corridors and Truck Access | 4 | 8 |

| PORTLAND CEMENT CONCRETE PAVEMENT SECTIONS | | |
|---|------------------------------|------------------------------------|
| TRAFFIC AREA | Concrete (Inches) | Aggregate Base (Inches) |
| Dumpster Approach | 6 | 6 |
| Dock Ramps | 6 | 6 |

The Earthwork Contractor shall ensure that field density tests have been performed to document the relative compaction of at least the upper 6 inches of structural fill. Preparation of the native soils shall be documented prior to placement of structural fill or aggregate base. All subgrade shall be compacted to a smooth non-yielding surface before placement of aggregate base. Aggregate base sections shall be compacted to a smooth non-yielding surface before placement of pavement sections.

The performance of the pavement can be enhanced by minimizing excess moisture which can reach the subgrade soils. The following recommendations should be followed, where possible:

- Site grading at a minimum 2% grade away from the pavements.
- Compaction of any utility trenches for landscaped areas to the same criteria as the pavement subgrade.
- Landscaped areas should have cutoff walls/moisture barriers adjacent to pavement areas to minimize or prevent moisture migration to subgrade soils.
- Consideration should be given to using "desert" landscaping and/or minimizing watering to help prevent surface runoff.
- Placing compacted backfill against the exterior side of curb and gutter.

6.8 Drainage and Moisture Protection

Foundation soils should generally not be allowed to become saturated during or after construction, except when necessary to increase moisture contents prior to construction. Infiltration of water into foundation or utility excavations should be prevented during construction. Utility lines should be properly installed and the backfill properly compacted to avoid possible sources for subsurface saturation.

Positive drainage away from the structures should be provided during construction and maintained throughout the life of the structures. Any downspouts, roof drains or scuppers should discharge into splash blocks or extensions and away from the structures. Backfill against footings, exterior walls and in utility trenches should be properly compacted and free of all construction debris to reduce the possibility of moisture infiltration.

Performance of the foundation system recommended in this report is dependent on the ability to keep moisture from penetrating the soils below foundations and slabs. Therefore, we recommend the following:

- Positive drainage should be maintained away from the structures, adjoining concrete slabs and block walls. Positive drainage of 2% minimum shall be maintained for areas adjacent to structures or block walls that are not covered by concrete or asphalt. The 2% should be maintained for a distance of 10 feet. Where concrete or asphalt abut structures or block walls, the surface of these materials should be sloped a minimum of 2% away from structures or block walls. If physical obstructions or lot lines prohibit 10 feet of horizontal distance, the slope should be provided to an approved alternate method of drainage.
- Structures should have roof drains/gutters with downspouts that discharge into splash blocks or extensions with the discharge directed away from structures.
- Landscaping adjacent to structural areas should be limited and consist of native vegetation utilizing drip-type irrigation. Sealed planters should be considered for these areas.

- Watering should be kept to a minimum.

It should be understood, if the above recommendations are not followed there would be an increased risk/potential for increasing moisture below foundations and slabs which could result in additional movement and distress to structures and slabs.

6.9 Concrete Slab on Grade

6.9.1 Interior Concrete Slabs

If grading recommendations are complied with, concrete floor slabs may be supported on a 12-inch layer of Type II or other select granular material. If the potential for a damp floor slab is a concern, moisture protection should be provided by a relatively impervious vapor barrier/retarder placed beneath interior slabs. The vapor barrier/retarder should be a Class A vapor barrier with a minimum thickness of 10 mils meeting the requirements of ASTM E1745, and should conform to and be placed in accordance with the requirements of the project structural engineer or architect. If the concrete is to be placed directly on Type II, select granular material, or sand, the Type II, select material, or sand should be moistened (but not saturated) prior to placement of concrete.

Recommendations presented by the American Concrete Institute (ACI 302-1R-96) for slabs-on-grade should be complied with for all concrete placement and curing operations. Improper curing techniques and/or excessive slump (water-cement ratio) could cause excessive drying/shrinkage resulting in random cracking and/or slab curling. Concrete slabs should be allowed to cure adequately before placing vinyl or other moisture sensitive floor coverings.

6.9.2 Exterior Concrete Slabs

Recommendations presented by the American Concrete Institute (ACI 302-1R-06) for slabs-on-grade should be complied with for all concrete placement and curing operations. Improper curing techniques and/or excessive slump (water-cement ratio) could cause excessive drying/shrinkage resulting in random cracking and/or slab curling. We recommend considering the following to help protect and/or reduce the potential for expansion/heave:

- Support exterior slabs on 12 inches of structural fill material meeting the requirements presented in the Earthwork section of this report.
- Maintain positive drainage away from the exterior slabs, where practical.
- Minimize landscaping adjacent to the exterior slabs.
- Placement of effective control joints on relatively close centers and isolation joints between slabs and other structural elements.

6.10 Corrosivity

Results of conductivity testing performed on a fill sample taken from Boring B-1 at a depth of 2-4 foot BEG indicate that the material is minimally corrosive to buried metal conduit. Based on a soluble sulfate concentration of 6.3 mg/Kg (ppm), this soil is considered *not* detrimental to normally formulated concrete.

Results of corrosion testing are provided in the attached Plate 20.

It should be understood that NOVA Geotechnical & Inspection Services personnel are not experts regarding corrosion and/or corrosion protection. We recommend consulting a “Corrosion Engineer” for recommendations regarding the necessity and/or method of cathodic protection.

7.0 OTHER SERVICES

NOVA Geotechnical & Inspection Services should be retained to provide a general review of final design plans and specifications in order that grading and foundation recommendations may be interpreted and implemented. In the event that any changes of the proposed project are planned, the conclusions and recommendations contained in this report should be reviewed and the report modified or supplemented as necessary.

NOVA Geotechnical & Inspection Services should also be retained to provide services during excavation, grading, foundation and construction phases of work. Observation of foundation excavations should be performed prior to placement of reinforcing and concrete to confirm that satisfactory bearing materials are present. Field and laboratory testing of concrete and soils should be performed to determine whether applicable requirements have been met.

The analyses and recommendations in this report are based in part upon data obtained from the field exploration. The nature and extent of variations beyond the locations of the explorations may not become evident until construction. If variations then appear evident, it may be necessary to re-evaluate the recommendations of this report.

8.0 CLOSURE

Our professional services were performed using the degree of care and skill ordinarily exercised, under similar circumstances, by reputable geotechnical engineers practicing in this or similar localities. No warranties, either express or implied, are intended or made. We prepared this report as an aid in design of the proposed project. This report is not a bidding document. Any contractor reviewing this report must draw his own conclusions regarding site conditions and specific construction techniques to be used on this project.

NOVA GEOTECHNICAL & INSPECTION SERVICES

Prepared by:

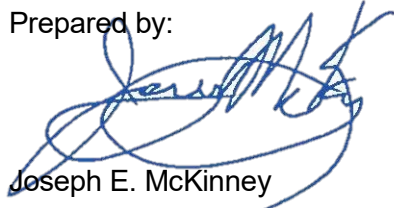

Joseph E. McKinney
Senior Geophysicist/Geologist

Reviewed by:



Dean R. Stanphill
Principal



04/19/19

APPENDIX

Site Exploration

The subsurface conditions of the site were as described in section 3.0: Site Exploration of this report.

Laboratory Testing

Laboratory testing was performed on selected samples of on-site soils. Tests were performed in general accordance with applicable ASTM or other applicable standards.

Field moisture content and dry density determinations were performed on undisturbed samples. Results of these tests are presented on the boring logs.

Sieve analyses and Atterberg Limits were performed to determine the grain-size distribution and soil classification of representative materials. The results are presented on Plates 14 through 16.

A consolidation test was performed on a representative sample to illustrate the compressibility of on-site soils. Water was added during testing to illustrate the influence of moisture on compressibility. The test result is presented on Plate 17.

An R-Value test was performed on a representative sample to measure the response of the soil to a vertically applied pressure. Test results are presented on Plate 18.

A direct shear test was performed on a sample from Boring B-1 at a depth of 2.5 feet. Normal stresses used for the test were 2000, 4000, and 8000 psf, and the sample was inundated. Following are the results of this test:

Cohesion, C (psf): 312
Phi angle, Φ (deg): 31.8
Tan(Φ): 0.62

Corrosion tests were performed on a selected sample of the on-site soils to determine corrosion to buried metal conduit and possible affects on concrete. Test results are attached on Plate 20.

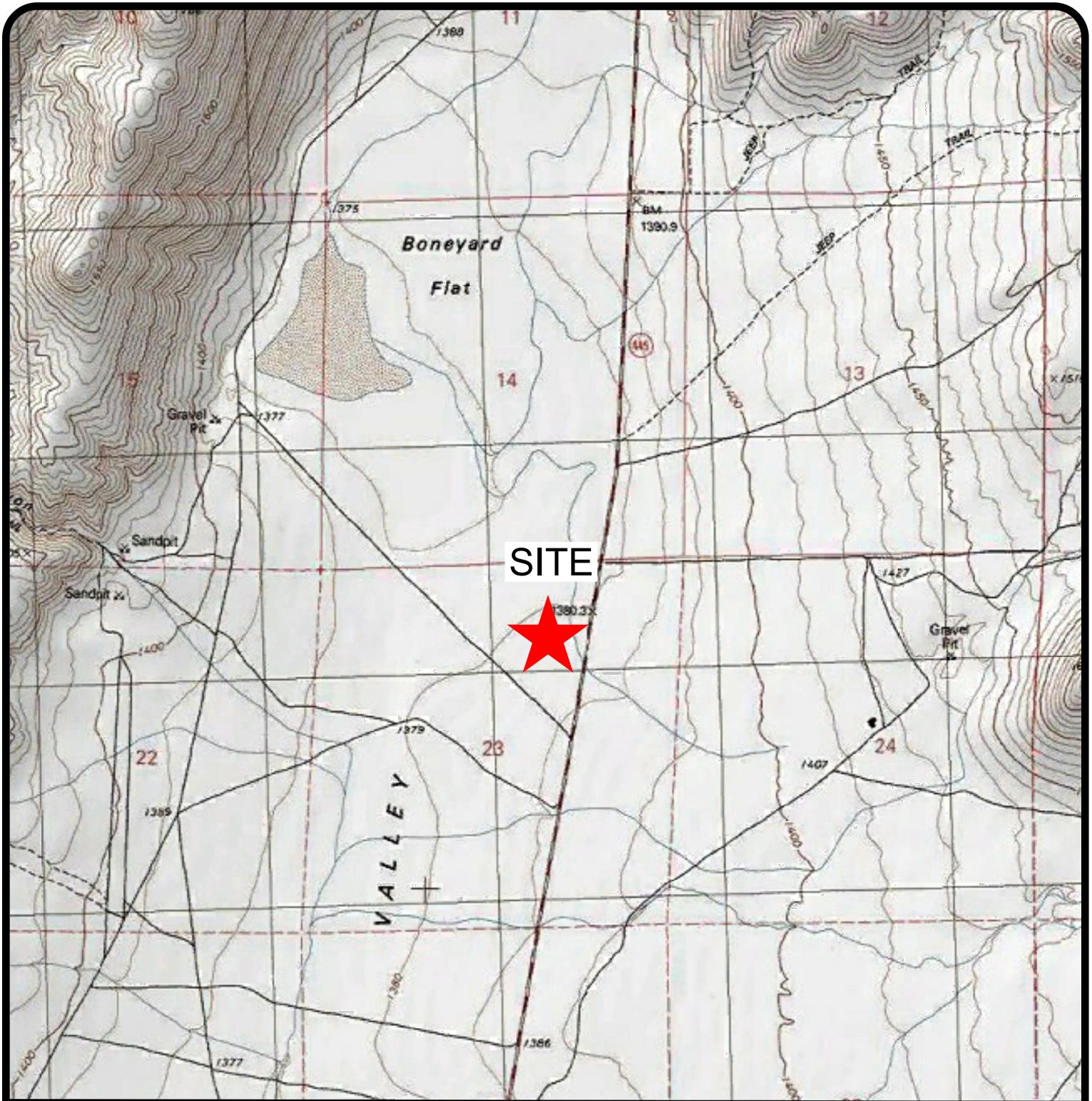

Base Map:
 USGS Topographic map,
 Reno 7.5- Minute Quadrangle



Job No. RG-19-036

Site Location Plan

04-19-2019



Luxe Locker - Spanish Springs
 SEC Ingenuity Ave. and Digital Ct.
 Sparks, Washoe County, Nevada

Plate No. 1

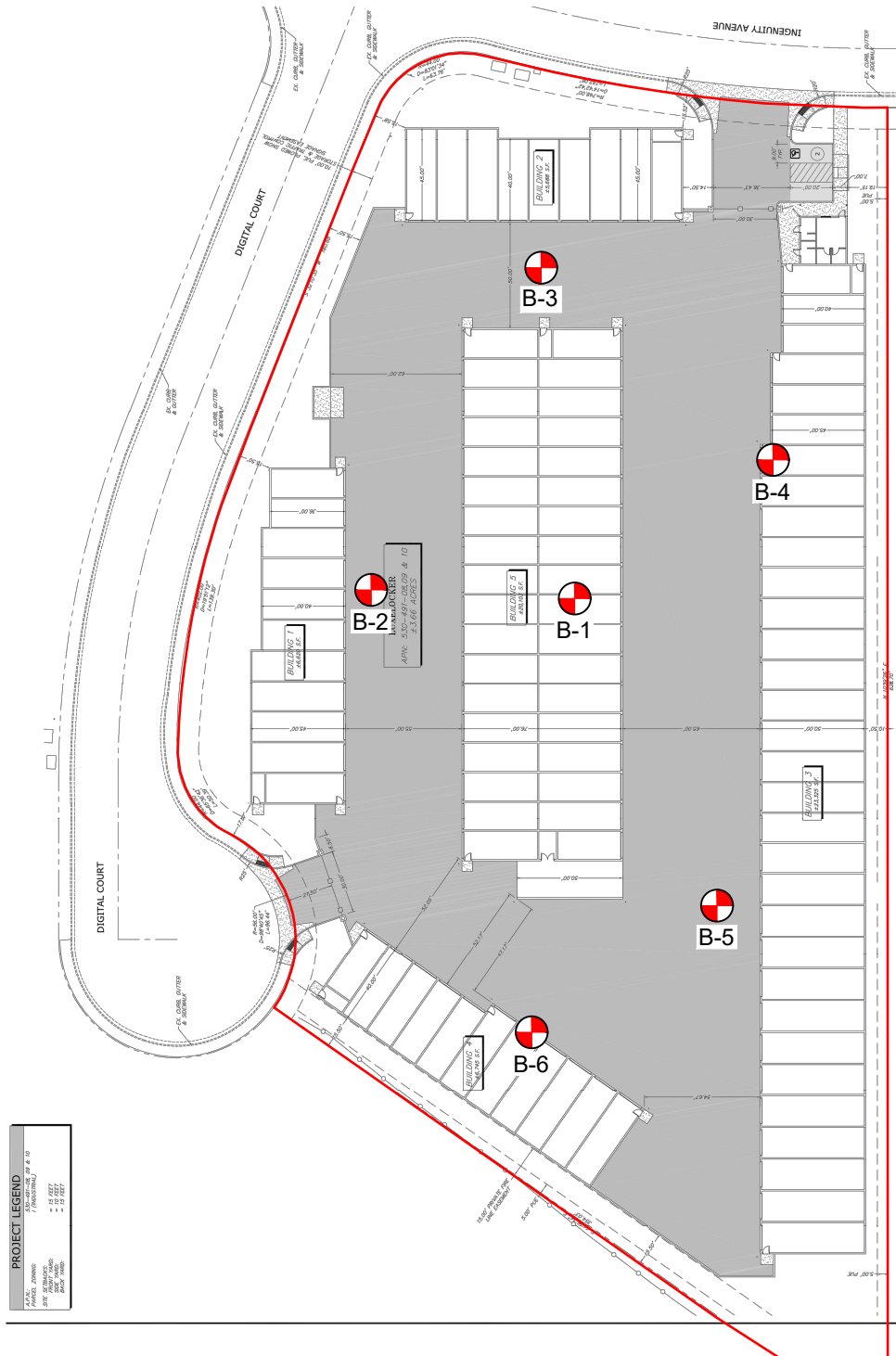

Image Source:
Google Earth



Key:
Boring Location B-1
Site Boundary

Job No. RG-19-036

Boring Location Plan

04-19-2019



Luxe Locker - Spanish Springs
SEC Ingenuity Ave. and Digital Ct.
Sparks, Washoe County, Nevada

Plate No. 2

National Flood Hazard Layer FIRMette



39°40'50.49"N



Legend

- SEE FIS REPORT FOR DETAILED LEGEND AND INDEX MAP FOR FIRM PANEL LAYOUT
- SPECIAL FLOOD HAZARD AREAS**
 - Without Base Flood Elevation (BFE) Zone A, V, A99
 - With BFE or Depth Zone AE, AO, AH, VE, AR
 - Regulatory Floodway
 - OTHER AREAS OF FLOOD HAZARD**
 - 0.2% Annual Chance Flood Hazard, Area of 1% annual chance flood with average depth less than one foot or with drainage areas of less than one square mile Zone X
 - Future Conditions 1% Annual Chance Flood Hazard Zone X
 - Area with Reduced Flood Risk due to Levee. See Notes. Zone X
 - Area with Flood Risk due to Levee Zone X
 - OTHER AREAS**
 - NO SCREEN Area of Minimal Flood Hazard Zone X
 - Effective LOMRs
 - Area of Undetermined Flood Hazard Zone X
 - GENERAL STRUCTURES**
 - Channel, Culvert, or Storm Sewer
 - Levee, Dike, or Floodwall
 - OTHER FEATURES**
 - 20.2 Water Surface Elevation
 - 17.5 Coastal Transect
 - Base Flood Elevation Line (BFE)
 - Limit of Study
 - Jurisdiction Boundary
 - Coastal Transect Baseline
 - Profile Baseline
 - Hydrographic Feature
 - MAP PANELS**
 - Digital Data Available
 - No Digital Data Available
 - Unmapped

The pin displayed on the map is an approximate point selected by the user and does not represent an authoritative property location.

This map complies with FEMA's standards for the use of digital flood maps if it is not void as described below. The basemap shown complies with FEMA's basemap accuracy standards.

The flood hazard information is derived directly from the authoritative NFHL web services provided by FEMA. This map was exported on 4/19/2019 at 12:02:02 PM and does not reflect changes or amendments subsequent to this date and time. The NFHL and effective information may change or become superseded by new data over time.

This map image is void if the one or more of the following map elements do not appear: basemap imagery, flood zone labels, legend, scale bar, map creation date, community identifiers, FIRM panel number, and FIRM effective date. Map images for unmapped and unmodernized areas cannot be used for regulatory purposes.

Source:
FEMA



Job No. RG-19-036

Flood Map

04-19-2019



Luxe Locker - Spanish Springs
SEC Ingenuity Ave. and Digital Ct.
Sparks, Washoe County, Nevada

Plate No. 4



LOG OF BORING

No. B-1

PROJECT: Luxe Locker - Spanish Springs **PROJECT NO.:** RG-19-036
CLIENT: Tectonics Design Group
PROJECT LOCATION: 11435, 11445, 11455 Digital Ct., Spanish Springs, NV
BORING LOCATION: 39° 40.611'N, 119° 42.157'W **ELEVATION:** 4536' NAVD88
DRILLER: Terra **LOGGED BY:** DAL
DRILLING METHOD: CME-75, 8" HSA **DATE:** 03/28/2019
DEPTH TO WATER, INITIAL: ∇ N/E **AFTER 24 HOURS:** ∇ **CAVING:** C

This information pertains only to this boring and should not be interpreted as being indicative of the site.

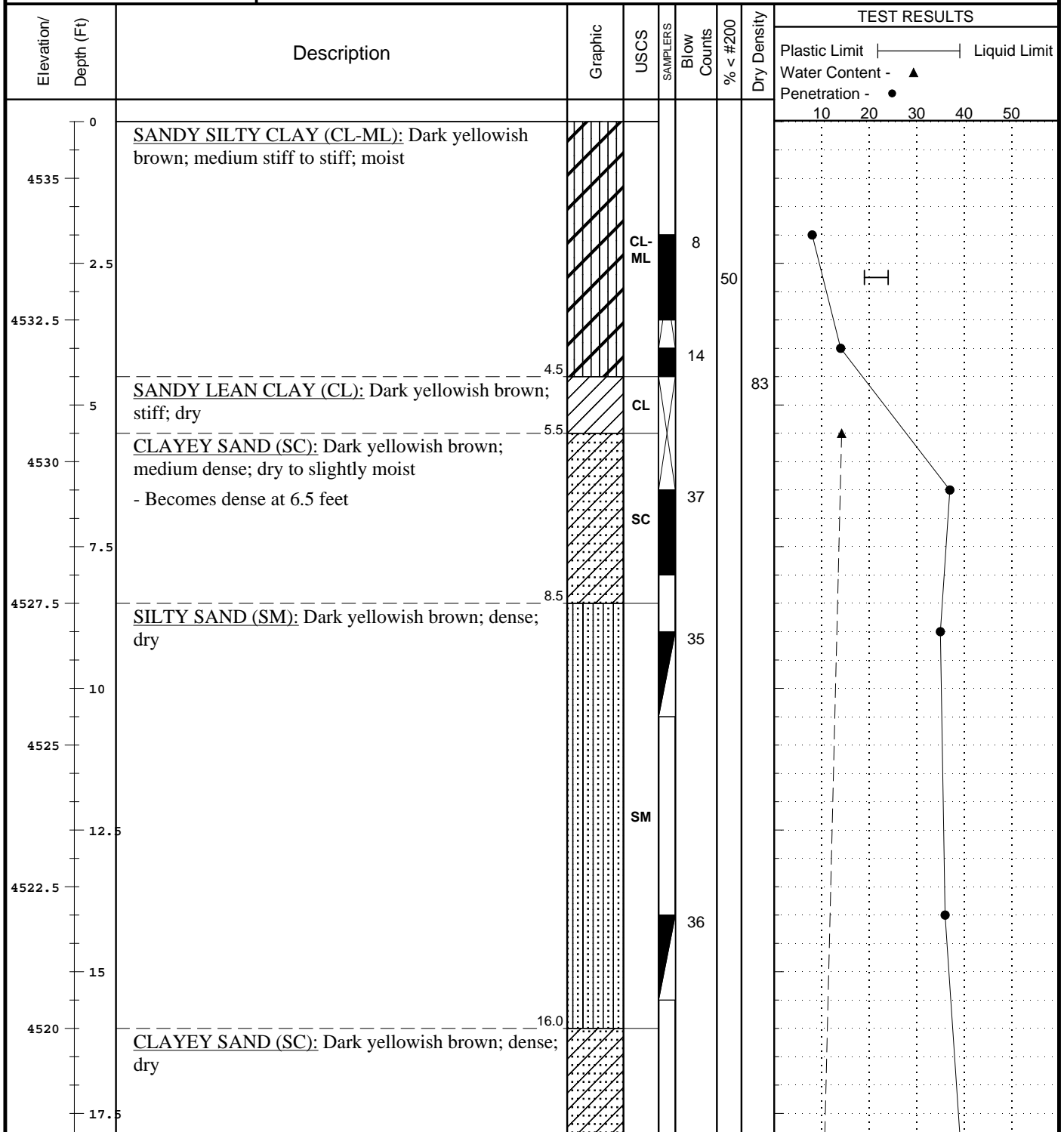



LOG OF BORING

No. B-1

PROJECT: Luxe Locker - Spanish Springs **PROJECT NO.:** RG-19-036
CLIENT: Tectonics Design Group
PROJECT LOCATION: 11435, 11445, 11455 Digital Ct., Spanish Springs, NV
BORING LOCATION: 39° 40.611'N, 119° 42.157'W **ELEVATION:** 4536' NAVD88
DRILLER: Terra **LOGGED BY:** DAL
DRILLING METHOD: CME-75, 8" HSA **DATE:** 03/28/2019
DEPTH TO WATER, INITIAL: ∇ N/E **AFTER 24 HOURS:** ∇ **CAVING:** C

This information pertains only to this boring and should not be interpreted as being indicative of the site.

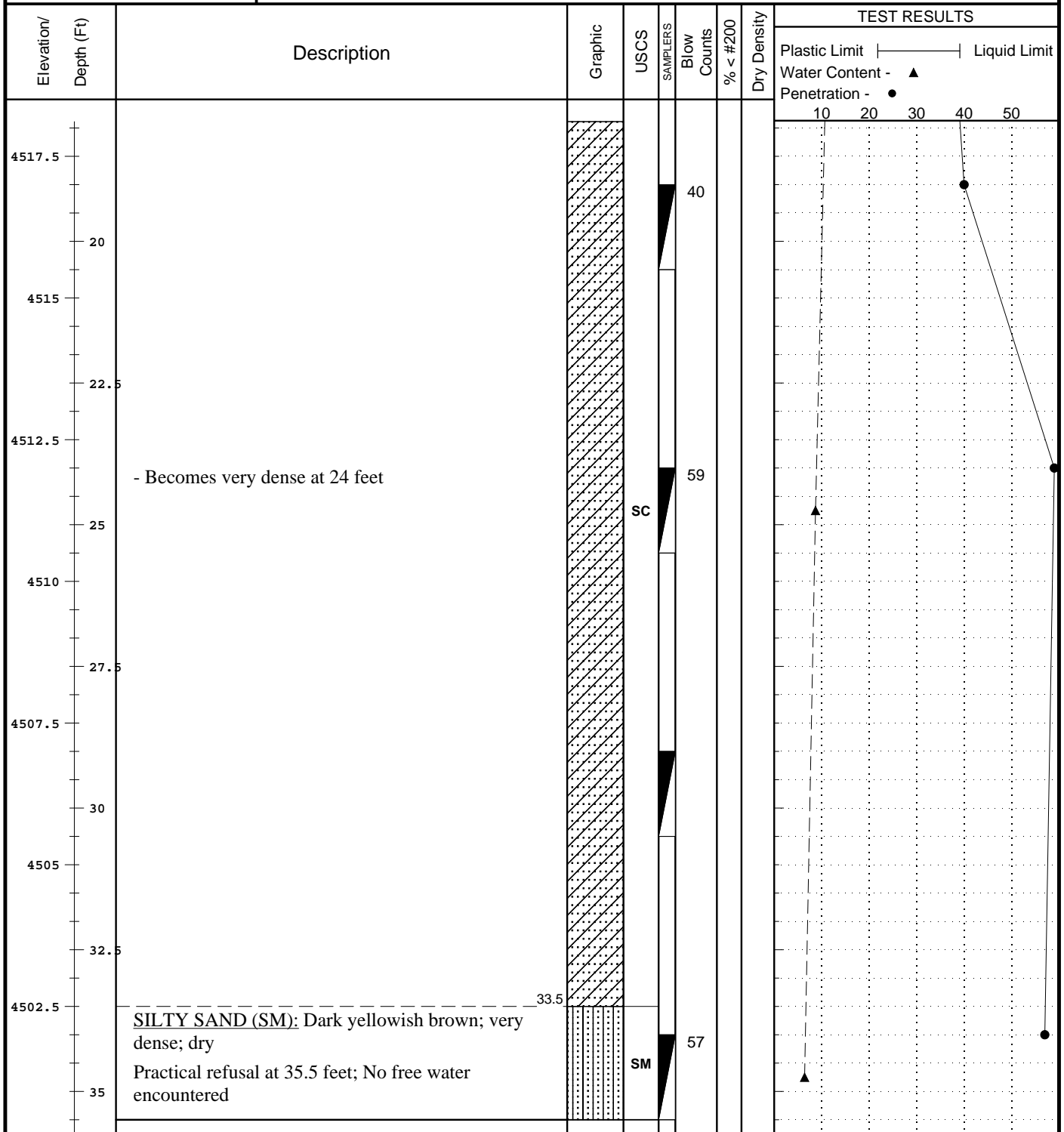



LOG OF BORING No. B-2

PROJECT: Luxe Locker - Spanish Springs **PROJECT NO.:** RG-19-036
CLIENT: Tectonics Design Group
PROJECT LOCATION: 11435, 11445, 11455 Digital Ct., Spanish Springs, NV
BORING LOCATION: 39° 40.614'N, 119° 42.178'W **ELEVATION:** 4536' NAVD88
DRILLER: Terra **LOGGED BY:** DAL
DRILLING METHOD: CME-75, 8" HSA **DATE:** 03/28/2019
DEPTH TO WATER, INITIAL: ∅ N/E **AFTER 24 HOURS:** ∅ **CAVING:** C

This information pertains only to this boring and should not be interpreted as being indicative of the site.

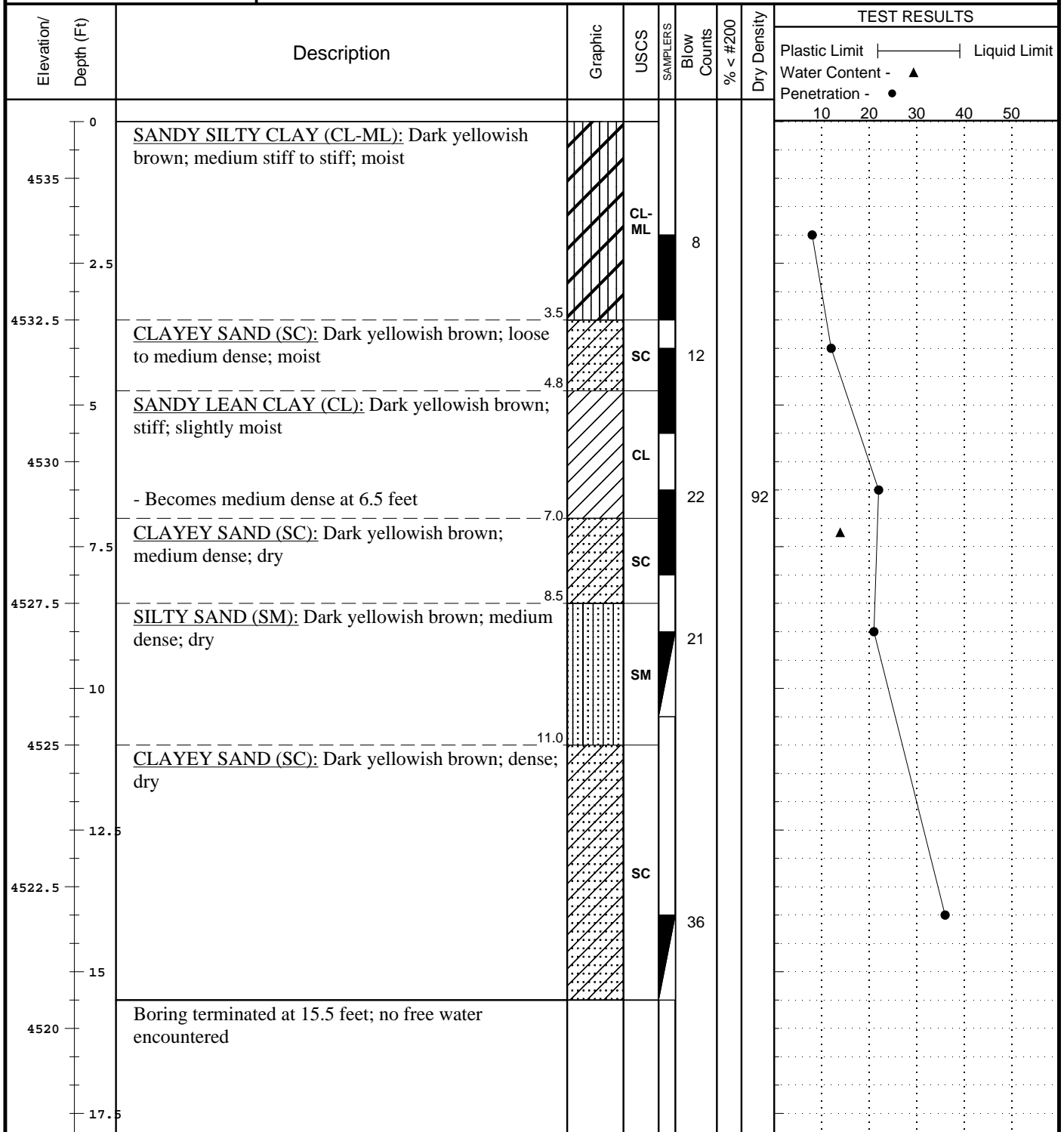



LOG OF BORING No. B-3

PROJECT: Luxe Locker - Spanish Springs **PROJECT NO.:** RG-19-036
CLIENT: Tectonics Design Group
PROJECT LOCATION: 11435, 11445, 11455 Digital Ct., Spanish Springs, NV
BORING LOCATION: 39° 40.636'N, 119° 42.155'W **ELEVATION:** 4536' NAVD88
DRILLER: Terra **LOGGED BY:** DAL
DRILLING METHOD: CME-75, 8" HSA **DATE:** 03/28/2019
DEPTH TO WATER, INITIAL: ∅ N/E **AFTER 24 HOURS:** ∅ **CAVING:** C

This information pertains only to this boring and should not be interpreted as being indicative of the site.

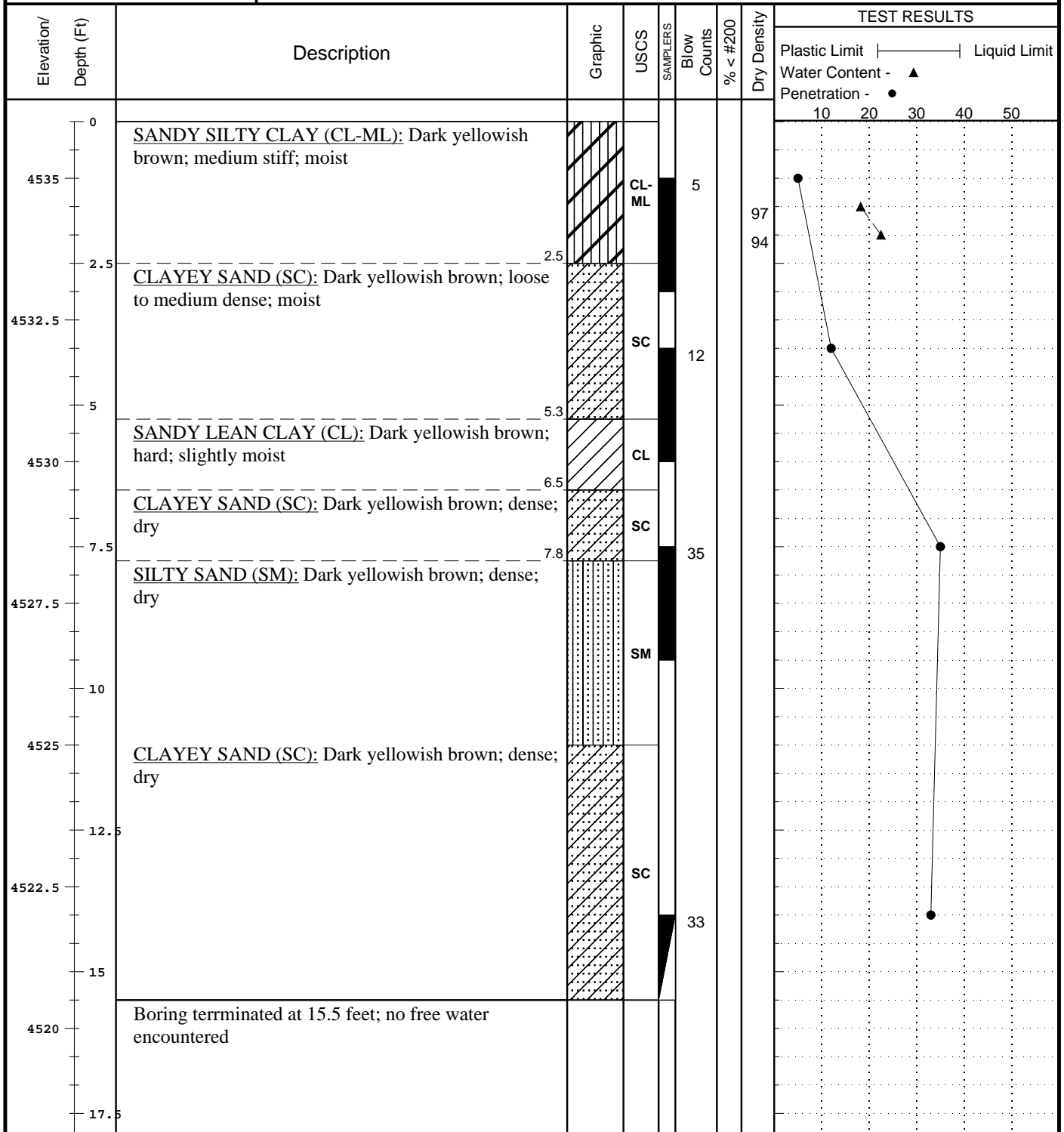



LOG OF BORING

No. B-4

PROJECT: Luxe Locker - Spanish Springs **PROJECT NO.:** RG-19-036
CLIENT: Tectonics Design Group
PROJECT LOCATION: 11435, 11445, 11455 Digital Ct., Spanish Springs, NV
BORING LOCATION: 39° 40.619'N, 119° 42.135'W **ELEVATION:** 4536' NAVD88
DRILLER: Terra **LOGGED BY:** DAL
DRILLING METHOD: CME-75, 8" HSA **DATE:** 03/26,28/2019
DEPTH TO WATER, INITIAL: ∇ N/E **AFTER 24 HOURS:** ∇ **CAVING:** C

This information pertains only to this boring and should not be interpreted as being indicative of the site.

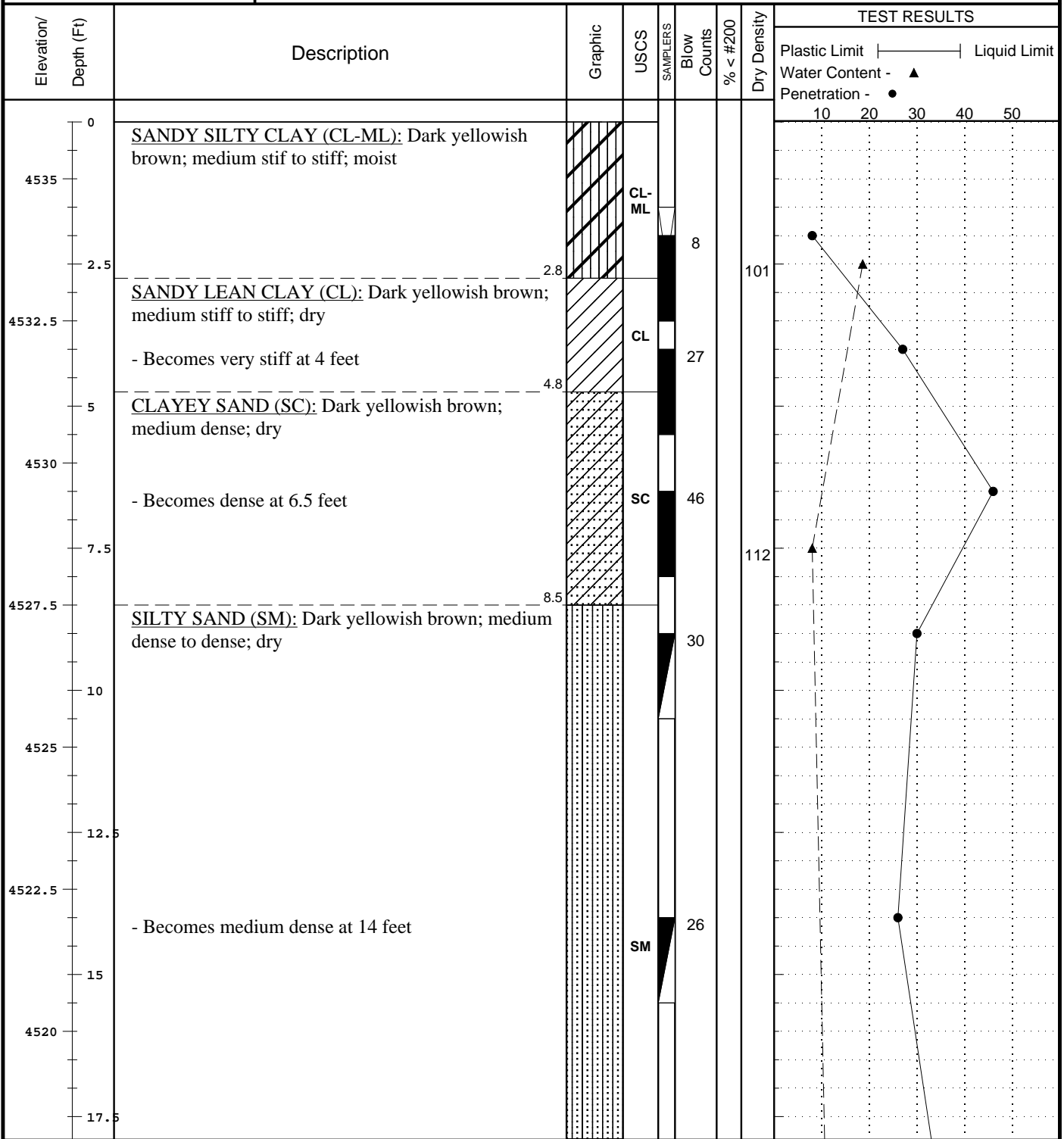



LOG OF BORING

No. B-4

PROJECT: Luxe Locker - Spanish Springs **PROJECT NO.:** RG-19-036
CLIENT: Tectonics Design Group
PROJECT LOCATION: 11435, 11445, 11455 Digital Ct., Spanish Springs, NV
BORING LOCATION: 39° 40.619'N, 119° 42.135'W **ELEVATION:** 4536' NAVD88
DRILLER: Terra **LOGGED BY:** DAL
DRILLING METHOD: CME-75, 8" HSA **DATE:** 03/26,28/2019
DEPTH TO WATER, INITIAL: ∅ N/E **AFTER 24 HOURS:** ∅ **CAVING>** C

This information pertains only to this boring and should not be interpreted as being indicative of the site.

| Elevation/ Depth (Ft) | Description | Graphic | USCS | SAMPLERS | Blow Counts | % < #200 | Dry Density | TEST RESULTS | |
|--------------------------|---|---------|------|----------|----------------|----------|-------------|---------------|--------------|
| | | | | | | | | Plastic Limit | Liquid Limit |
| 4517.5 | | | | | 35 | | | | |
| 20 | | | | | | | | | |
| 4515 | Boring terminated at 20.5 feet; no free water encountered | | | | | | | | |
| 22.5 | | | | | | | | | |
| 4512.5 | | | | | | | | | |
| 25 | | | | | | | | | |
| 4510 | | | | | | | | | |
| 27.5 | | | | | | | | | |
| 4507.5 | | | | | | | | | |
| 30 | | | | | | | | | |
| 4505 | | | | | | | | | |
| 32.5 | | | | | | | | | |
| 4502.5 | | | | | | | | | |
| 35 | | | | | | | | | |



LOG OF BORING

No. B-5

PROJECT: Luxe Locker - Spanish Springs **PROJECT NO.:** RG-19-036
CLIENT: Tectonics Design Group
PROJECT LOCATION: 11435, 11445, 11455 Digital Ct., Spanish Springs, NV
BORING LOCATION: 39° 40.585'N, 119° 42.147'W **ELEVATION:** 4536' NAVD88
DRILLER: Terra **LOGGED BY:** DAL
DRILLING METHOD: CME-75, 8" HSA **DATE:** 03/22/2019
DEPTH TO WATER, INITIAL: ∅ N/E **AFTER 24 HOURS:** ∅ **CAVING:** C

This information pertains only to this boring and should not be interpreted as being indicative of the site.

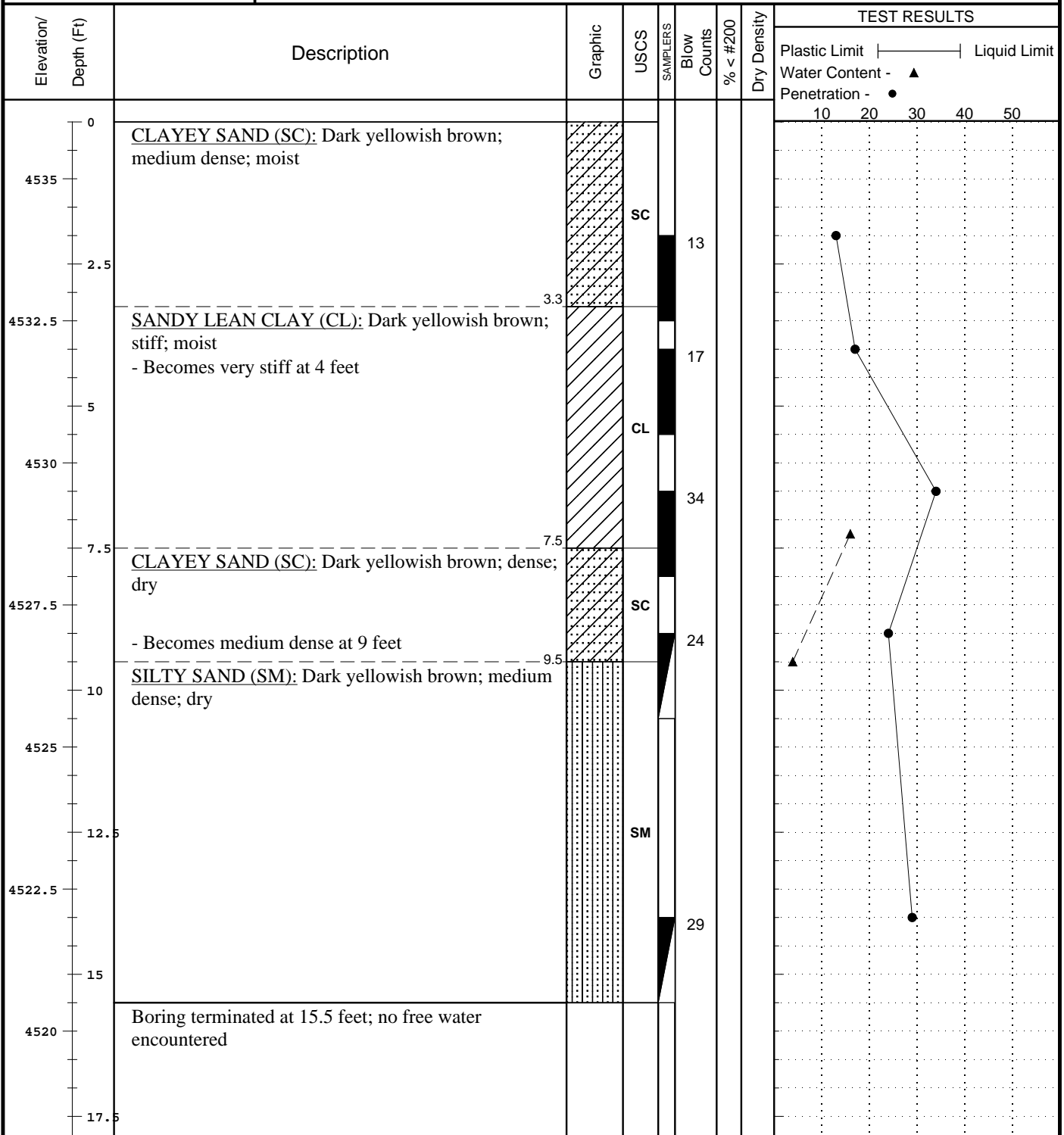



PROJECT: Luxe Locker - Spanish Springs **PROJECT NO.:** RG-19-036
CLIENT: Tectonics Design Group
PROJECT LOCATION: 11435, 11445, 11455 Digital Ct., Spanish Springs, NV
BORING LOCATION: 39° 40.578'N, 119° 42.169'W **ELEVATION:** 4536' NAVD88
DRILLER: Terra **LOGGED BY:** DAL
DRILLING METHOD: CME-75, 8" HSA **DATE:** 03/22/2019
DEPTH TO WATER, INITIAL: ∅ N/E **AFTER 24 HOURS:** ∅ **CAVING:** C

LOG OF BORING

No. B-6

This information pertains only to this boring and should not be interpreted as being indicative of the site.

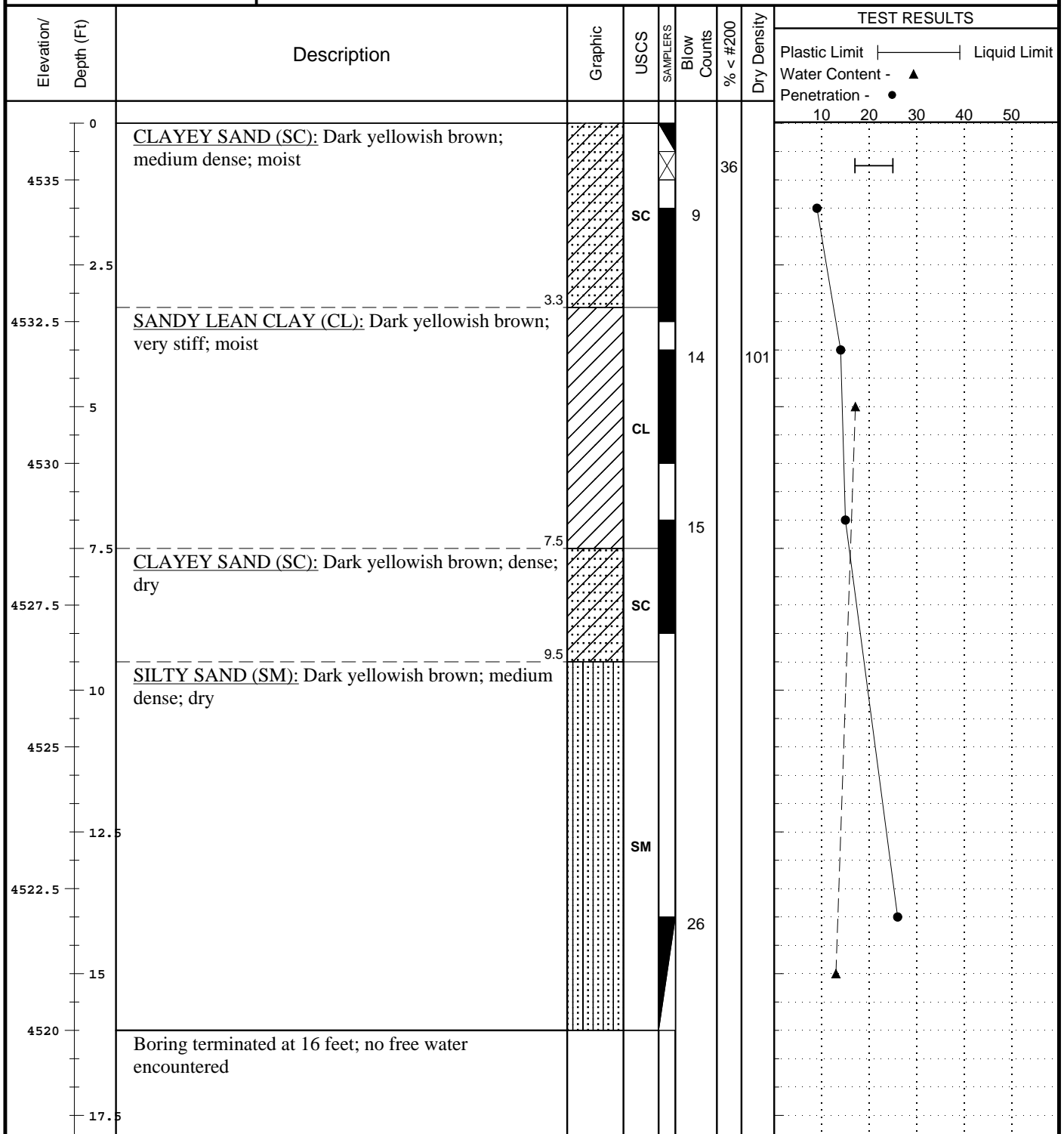

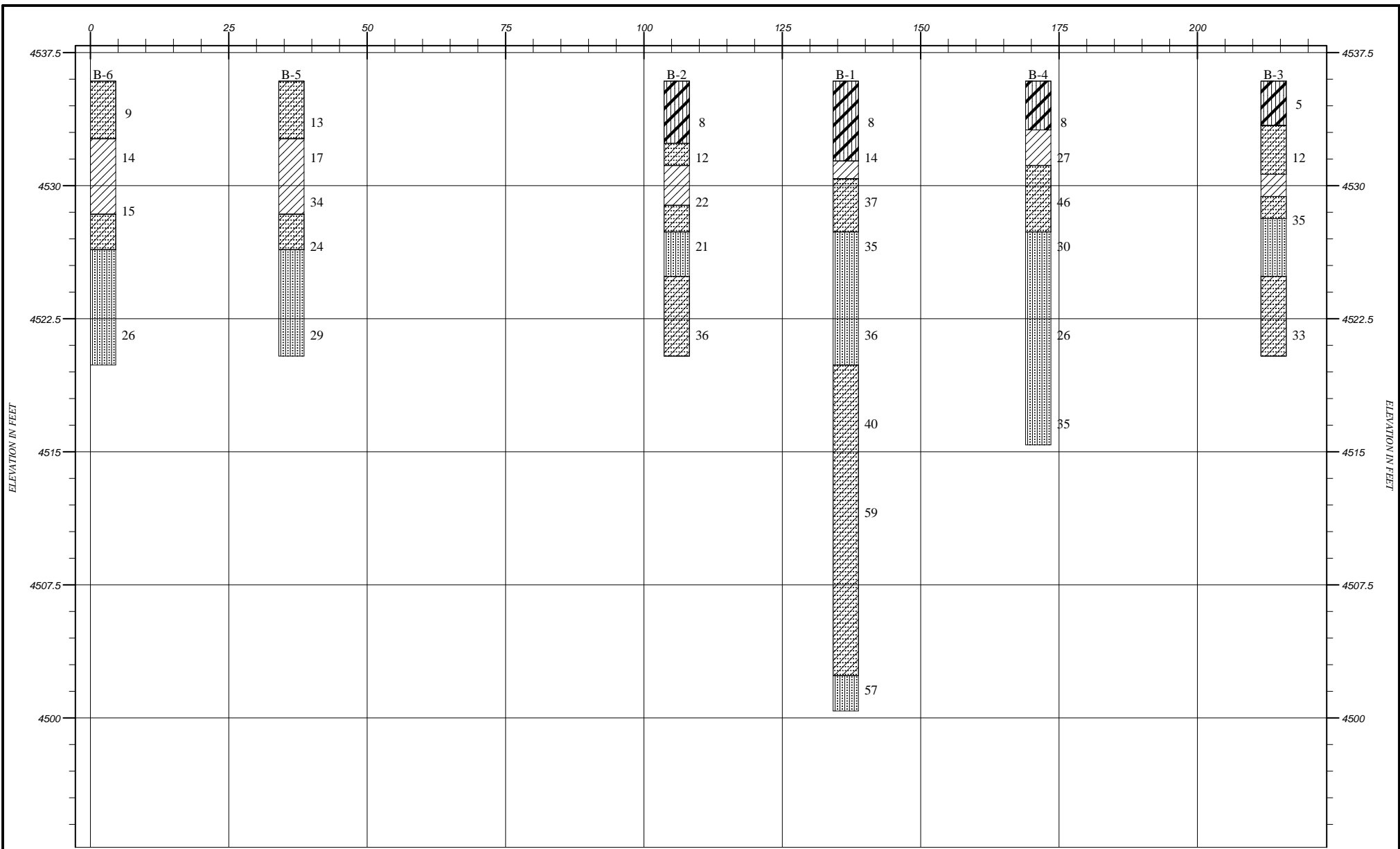



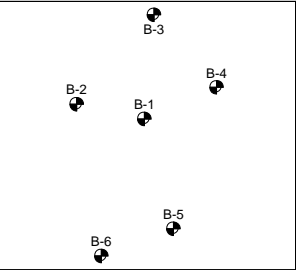

Plan View



Strata symbols

-  Clayey sand
-  Low plasticity clay
-  Silty sand
-  Silty low plasticity clay

| | | |
|--|----------------------|------------------------|
| Nova Geotechnical and Inspection Services | | |
| GENERALIZED SOIL PROFILE | | |
| HORIZONTAL SCALE: 1"=(proportional) | DRAWN BY/APPROVED BY | DATE DRAWN |
| VERTICAL SCALE: 1"=7.5' | JEM | 18-Apr-19 |
| Luxe Locker - Spanish Springs | | |
| PROJECT NO. RG-19-036 | | PLATE NUMBER 11 |

| MAJOR DIVISIONS | | | SYMBOLS | | TYPICAL DESCRIPTIONS | |
|--|---|---|---------------------------|---|---|--|
| | | | GRAPH | LETTER | | |
| COARSE GRAINED SOILS | GRAVEL AND GRAVELLY SOILS | CLEAN GRAVELS (LITTLE OR NO FINES) | | GW | WELL-GRADED GRAVELS, GRAVEL - SAND MIXTURES, LITTLE OR NO FINES | |
| | | GRAVELS WITH FINES (APPRECIABLE AMOUNT OF FINES) | | GP | POORLY-GRADED GRAVELS, GRAVEL - SAND MIXTURES, LITTLE OR NO FINES | |
| | | GRAVELS WITH FINES (APPRECIABLE AMOUNT OF FINES) | | GM | SILTY GRAVELS, GRAVEL - SAND - SILT MIXTURES | |
| | SAND AND SANDY SOILS | CLEAN SANDS (LITTLE OR NO FINES) | | SW | WELL-GRADED SANDS, GRAVELLY SANDS, LITTLE OR NO FINES | |
| | | CLEAN SANDS (LITTLE OR NO FINES) | | SP | POORLY-GRADED SANDS, GRAVELLY SAND, LITTLE OR NO FINES | |
| | | SANDS WITH FINES (APPRECIABLE AMOUNT OF FINES) | | SM | SILTY SANDS, SAND - SILT MIXTURES | |
| FINE GRAINED SOILS | SANDS WITH FINES (APPRECIABLE AMOUNT OF FINES) | SANDS WITH FINES (APPRECIABLE AMOUNT OF FINES) | | SC | CLAYEY SANDS, SAND - CLAY MIXTURES | |
| | | SILTS AND CLAYS | LIQUID LIMIT LESS THAN 40 | | ML | INORGANIC SILTS AND VERY FINE SANDS, ROCK FLOUR, SILTY OR CLAYEY FINE SANDS OR CLAYEY SILTS WITH SLIGHT PLASTICITY |
| | | | LIQUID LIMIT LESS THAN 40 | | CL | INORGANIC CLAYS OF LOW TO MEDIUM PLASTICITY, GRAVELLY CLAYS, SANDY CLAYS, SILTY CLAYS, LEAN CLAYS |
| | LIQUID LIMIT LESS THAN 40 | | | OL | ORGANIC SILTS AND ORGANIC SILTY CLAYS OF LOW PLASTICITY | |
| | SILTS AND CLAYS | LIQUID LIMIT GREATER THAN 50 | | MH | INORGANIC SILTS, MICACEOUS OR DIATOMACEOUS FINE SAND OR SILTY SOILS | |
| | | LIQUID LIMIT GREATER THAN 50 | | CH | INORGANIC CLAYS OF HIGH PLASTICITY | |
| LIQUID LIMIT GREATER THAN 50 | | | OH | ORGANIC CLAYS OF MEDIUM TO HIGH PLASTICITY, ORGANIC SILTS | | |
| HIGHLY ORGANIC SOILS | | | | PT | PEAT, HUMUS, SWAMP SOILS WITH HIGH ORGANIC CONTENTS | |
| NOVA GEOTECHNICAL & INSPECTION SERVICES | CLIENT: | | | | Materials Classification | |
| | PROJECT: | | | | | PROJECT NO.: |

KEY TO SYMBOLS

Symbol Description

Strata symbols



Silty low plasticity
clay



Low plasticity
clay



Clayey sand/
Low plasticity clay



Silty sand

Misc. Symbols



Water content

Soil Samplers



Bulk sample taken
from 6 in. auger



California sampler



Standard penetration test



Bulk/Grab sample

Notes:

1. Exploratory borings drilled March 22 and 28, 2019 using 8-inch outside diameter continuous flight power augers.
2. Free water was not encountered in any of the borings.
3. Boring locations were recorded using a hand-held GPS receiver. Elevations taken from the Reno 7.5-minute quadrangle topographic map
4. These logs are subject to the limitations, conclusions, and recommendations in the geotechnical investigation report.
5. Results of tests conducted on select samples are reported on the logs.

Particle Size Distribution Report



| % +3" | % Gravel | | % Sand | | | % Fines | |
|-------|----------|------|--------|--------|------|---------|------|
| | Coarse | Fine | Coarse | Medium | Fine | Silt | Clay |
| 0 | 0 | 0 | 1 | 10 | 39 | 50 | |

| SIEVE SIZE | PERCENT FINER | SPEC.* PERCENT | PASS? (X=NO) |
|------------|---------------|----------------|--------------|
| .375" | 100 | | |
| #4 | 100 | | |
| #10 | 99 | | |
| #20 | 95 | | |
| #40 | 89 | | |
| #60 | 83 | | |
| #100 | 69 | | |
| #200 | 50 | | |

Soil Description
Sandy silty clay

Atterberg Limits
 PL= 19 LL= 24 PI= 5

Coefficients
 D₉₀= 0.4674 D₈₅= 0.2791 D₆₀= 0.1102
 D₅₀= D₃₀= D₁₅=
 D₁₀= C_u= C_c=

Classification
 USCS= CL-ML AASHTO= A-4(0)

Remarks

* (no specification provided)

Source of Sample: B-1 Depth: 2.0
 Sample Number: 19-069

Date: 4-11-19

**Nova Geotechnical
 and Inspection Services
 Reno, Nevada**

Client: Tectonics Design Group
 Project: Luxe Locker - Spanish Springs

Project No: RG-19-036

Plate 14

Particle Size Distribution Report

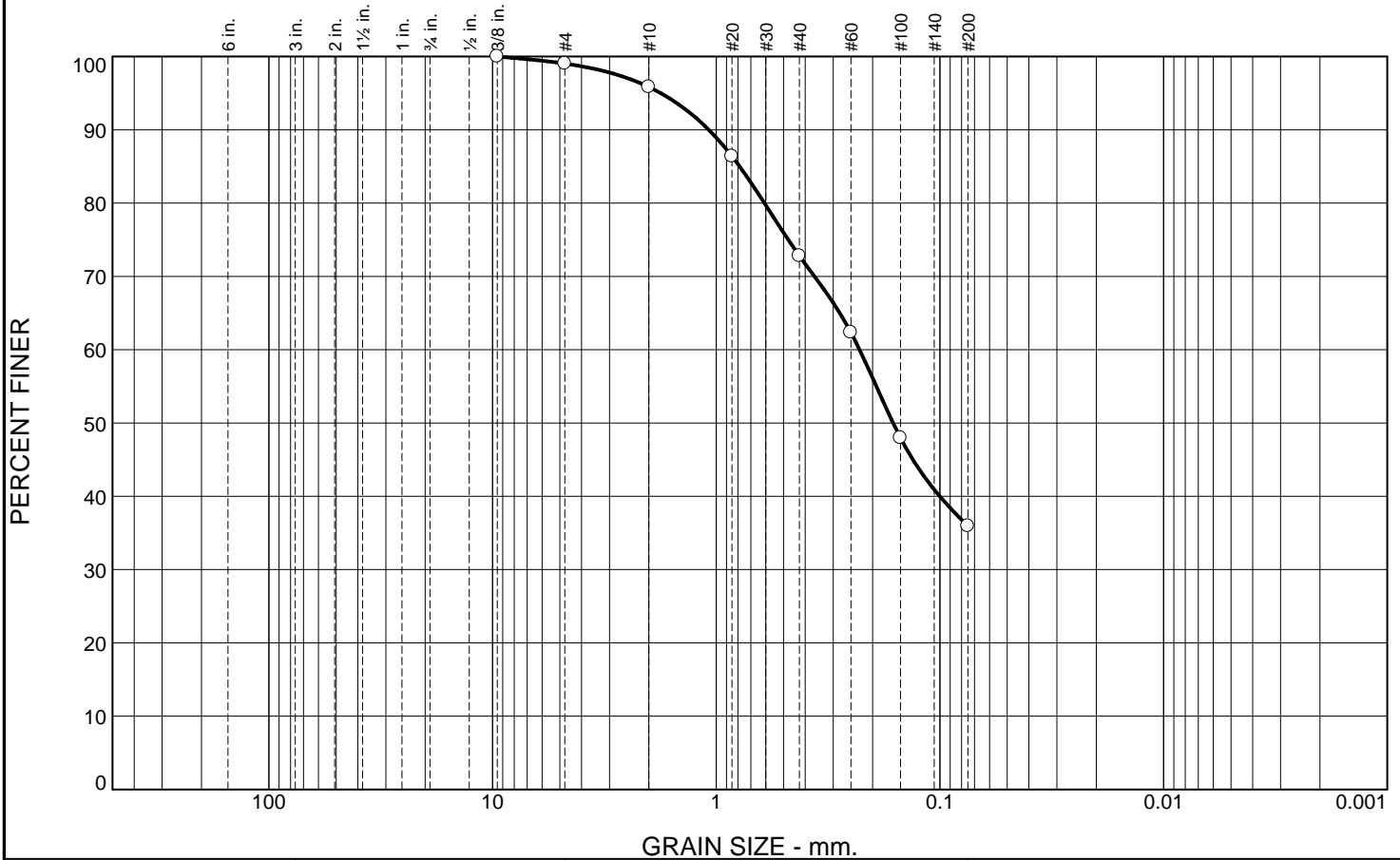

| % +3" | % Gravel | | % Sand | | | % Fines | |
|-------|----------|------|--------|--------|------|---------|------|
| | Coarse | Fine | Coarse | Medium | Fine | Silt | Clay |
| 0 | 0 | 1 | 3 | 23 | 37 | 36 | |

| SIEVE SIZE | PERCENT FINER | SPEC.* PERCENT | PASS? (X=NO) |
|------------|---------------|----------------|--------------|
| .375" | 100 | | |
| #4 | 99 | | |
| #10 | 96 | | |
| #20 | 86 | | |
| #40 | 73 | | |
| #60 | 62 | | |
| #100 | 48 | | |
| #200 | 36 | | |

Soil Description
Clayey sand

Atterberg Limits
PL= 17 LL= 25 PI= 8

Coefficients
 D₉₀= 1.0791 D₈₅= 0.7859 D₆₀= 0.2286
 D₅₀= 0.1620 D₃₀= D₁₅=
 D₁₀= C_u= C_c=

Classification
USCS= SC AASHTO= A-4(0)

Remarks

* (no specification provided)

Source of Sample: B-6
Sample Number: 19-058

Depth: 0.5

Date: 4-11-19

**Nova Geotechnical
and Inspection Services
Reno, Nevada**

Client: Tectonics Design Group
Project: Luxe Locker - Spanish Springs

Project No: RG-19-036

Plate 15

LIQUID AND PLASTIC LIMITS TEST REPORT

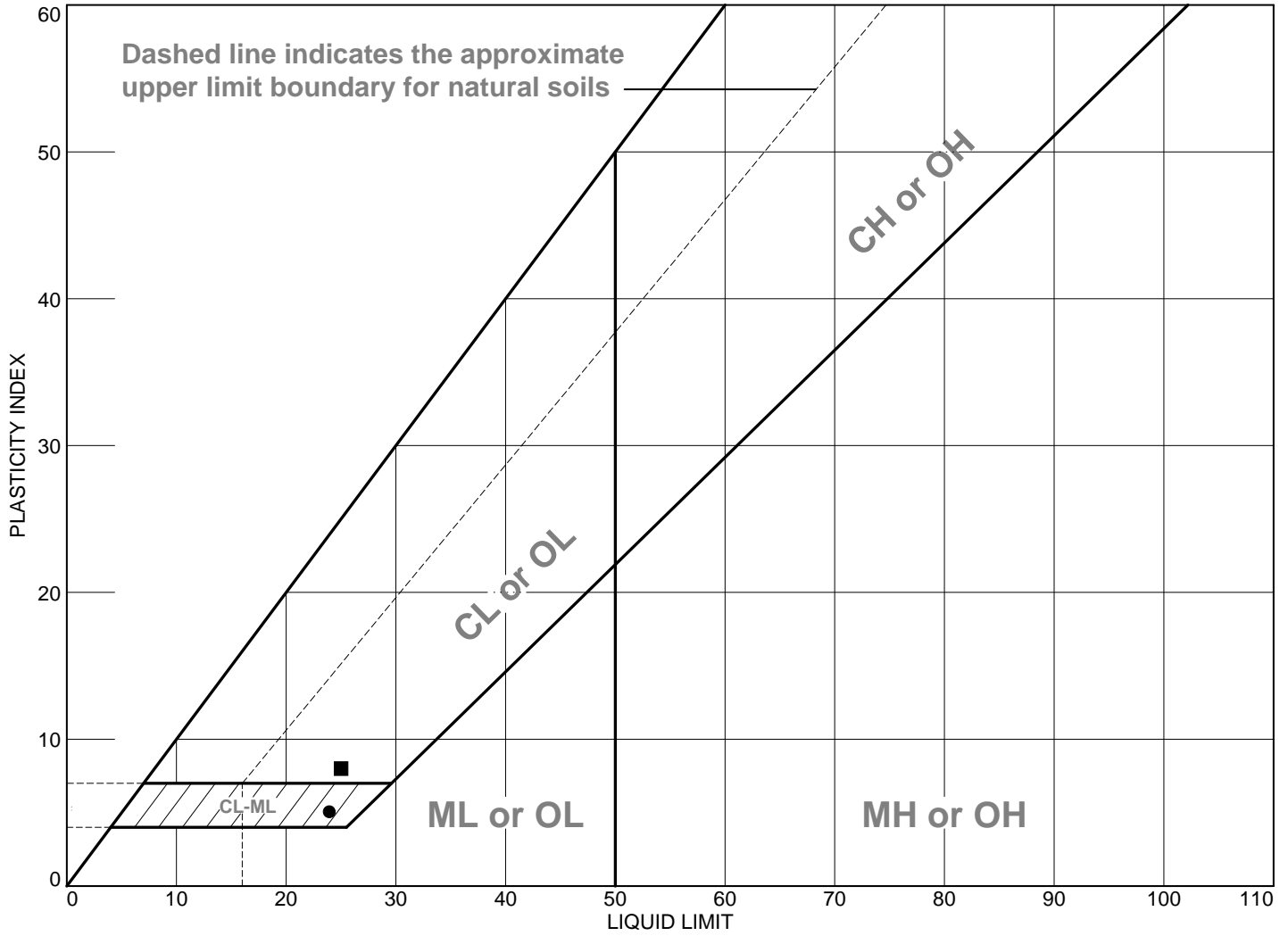

| | MATERIAL DESCRIPTION | LL | PL | PI | %<#40 | %<#200 | USCS |
|---|----------------------|----|----|----|-------|--------|-------|
| ● | Sandy silty clay | 24 | 19 | 5 | 89 | 50 | CL-ML |
| ■ | Clayey sand | 25 | 17 | 8 | 73 | 36 | SC |
| | | | | | | | |
| | | | | | | | |

Project No. RG-19-036 **Client:** Tectonics Design Group

Project: Luxe Locker - Spanish Springs

● **Source of Sample:** B-1 **Depth:** 2.0 **Sample Number:** 19-069

■ **Source of Sample:** B-6 **Depth:** 0.5 **Sample Number:** 19-058

**Nova Geotechnical
and Inspection Services
Reno, Nevada**

Remarks:

Plate 16

CONSOLIDATION TEST REPORT

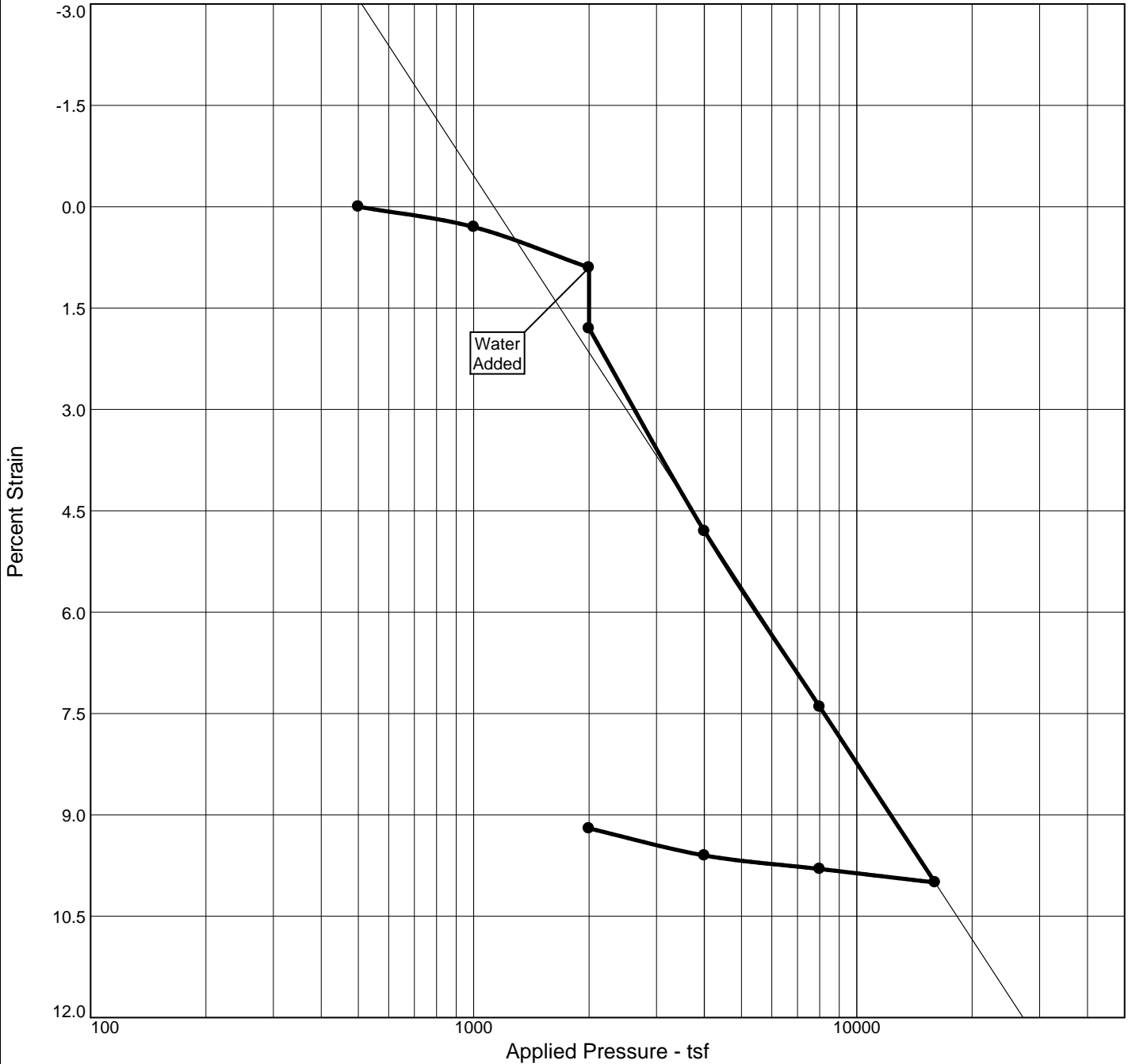

| Natural | | Dry Dens. (pcf) | LL | PI | Sp. Gr. | Overburden (tsf) | P _C (tsf) | C _C | C _S | Swell Press. (tsf) | Clpse. % | e ₀ |
|---------|--------|-----------------|----|----|---------|------------------|----------------------|----------------|----------------|--------------------|----------|----------------|
| Sat. | Moist. | | | | | | | | | | | |
| 45.7 % | 10.8 % | 101.9 | | | 2.65 | | 4062.2 | 0.14 | 0.01 | | 0.9 | 0.623 |

| MATERIAL DESCRIPTION | USCS | AASHTO |
|----------------------|------|--------|
| Clayey Sand | SC | |

| | |
|---|------------------------|
| <p>Project No. RG-19-036 Client: Tectonics Design Group</p> <p>Project: Luxe Locker - Spanish Springs</p> <p>Source of Sample: B-2 Depth: 2.5</p> <p style="text-align: center;">Nova Geotechnical and Inspection Services Reno, Nevada</p> | <p>Remarks:</p> |
|---|------------------------|

R-VALUE TEST REPORT

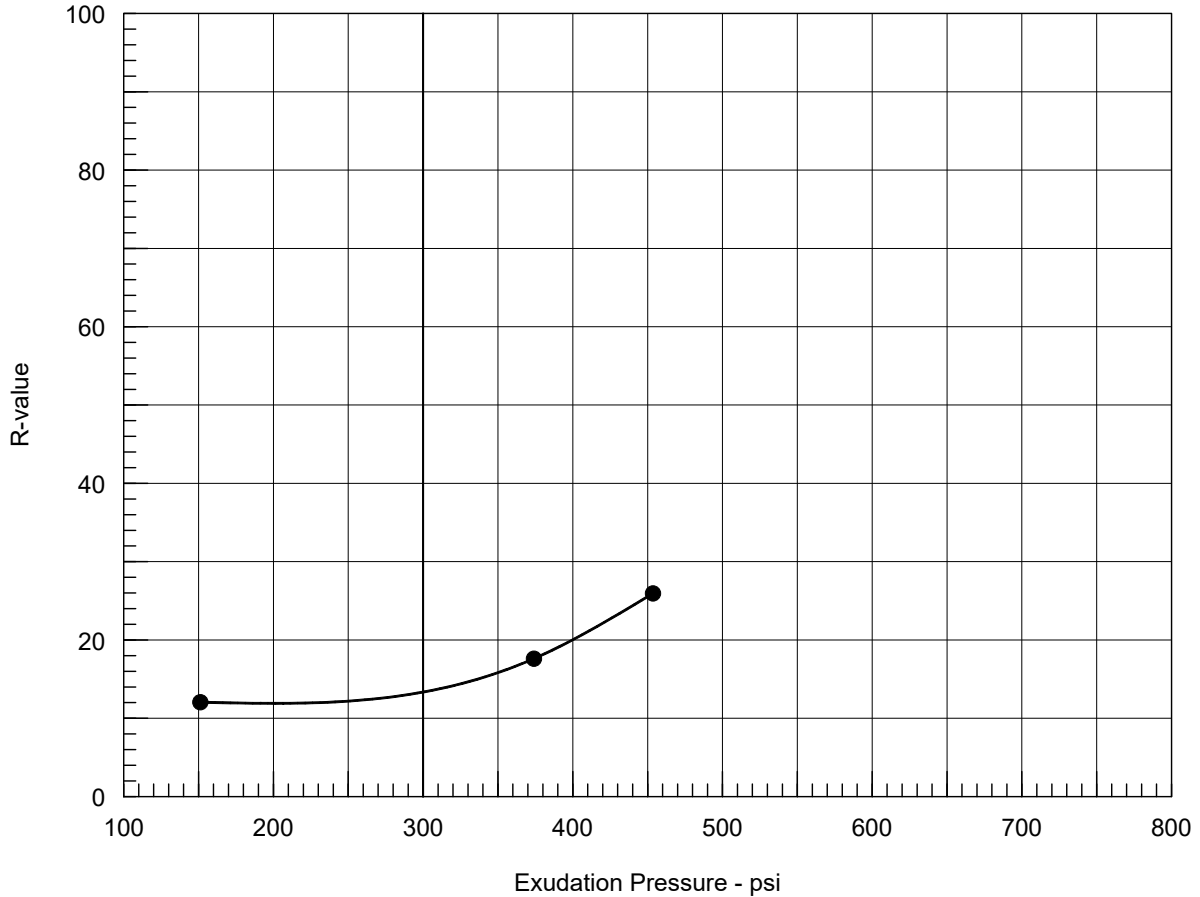

Resistance R-Value and Expansion Pressure - ASTM D2844

| No. | Compact. Pressure psi | Density pcf | Moist. % | Expansion Pressure psf | Horizontal Press. psi @ 160 psi | Sample Height in. | Exud. Pressure psi | R Value | R Value Corr. |
|-----|-----------------------|-------------|----------|------------------------|---------------------------------|-------------------|--------------------|---------|---------------|
| 1 | 200 | 112.3 | 16.8 | 0 | 124 | 2.66 | 374 | 15.9 | 17.6 |
| 2 | 100 | 107.1 | 19.3 | 0 | 132 | 2.55 | 151 | 12.1 | 12.1 |
| 3 | 225 | 112.7 | 17.1 | 0 | 112 | 2.61 | 454 | 24.1 | 25.9 |

| | |
|---------------------|-----------------------------|
| Test Results | Material Description |
|---------------------|-----------------------------|

| | |
|--|------------------|
| R-value at 300 psi exudation pressure = 13.3 | Sandy silty clay |
|--|------------------|

| | |
|--|--|
| Project No.: RG-19-036 Project: Luxe Locker - Spanish Springs Source of Sample: B-1 Depth: 2.0 Sample Number: 19-069 Date: 19-Apr-19 | Tested by: Checked by: Remarks: |
|--|--|

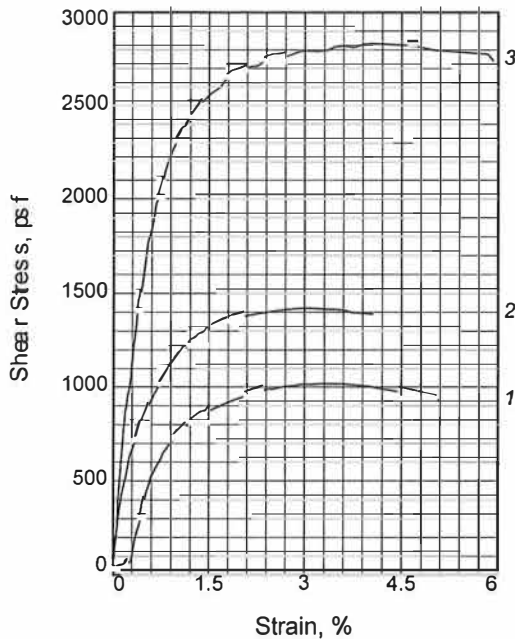
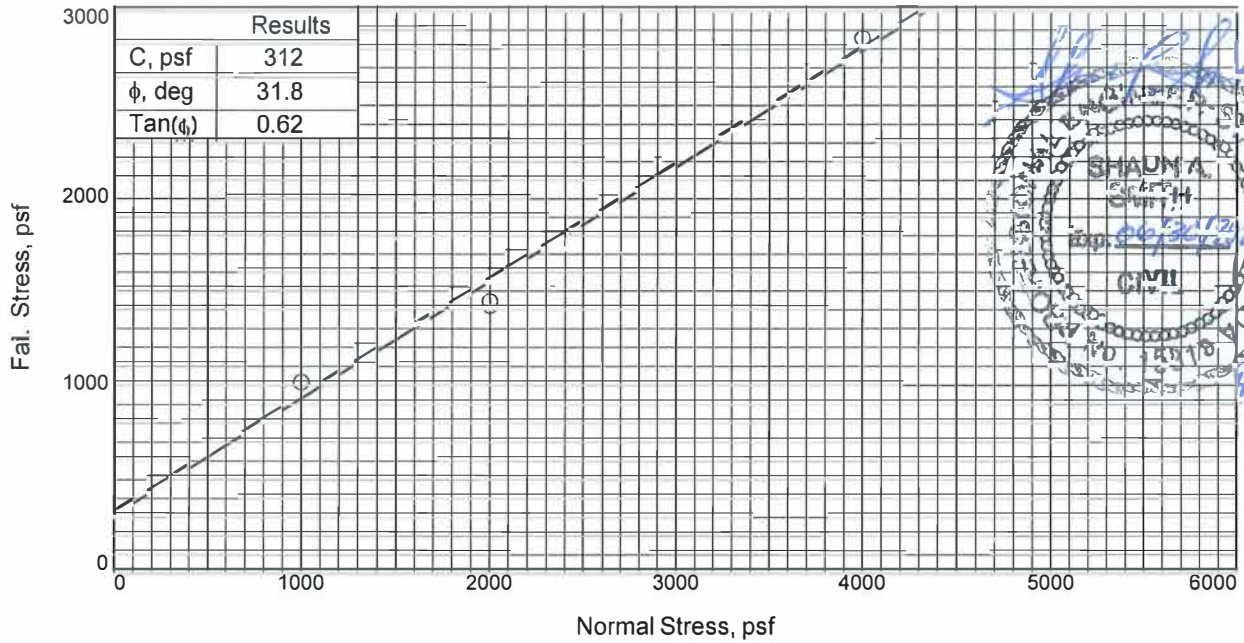

| Sample No. | 1 | 2 | 3 | |
|-----------------------|------------------|--------|--------|--------|
| Initial | Water Content, % | 9.6 | 9.6 | 9.6 |
| | Dry Density, pcf | 103.4 | 106.2 | 110.1 |
| | Saturation, % | 41.1 | 44.1 | 48.8 |
| | Void Ratio | 0.6295 | 0.5874 | 0.5304 |
| | Diameter, in. | 2.42 | 2.42 | 2.42 |
| | Height, in. | 1.00 | 1.00 | 1.00 |
| At Test | Water Content, % | 22.2 | 20.7 | 19.0 |
| | Dry Density, pcf | 105.4 | 108.2 | 111.4 |
| | Saturation, % | 100.0 | 100.0 | 100.0 |
| | Void Ratio | 0.5994 | 0.5574 | 0.5136 |
| | Diameter, in. | 2.42 | 2.42 | 2.42 |
| | Height, in. | 0.98 | 0.98 | 0.99 |
| Normal Stress, psf | 1000 | 2000 | 4000 | |
| Fail. Stress, psf | 1017 | 1421 | 2833 | |
| Strain, % | 3.2 | 3.0 | 4.0 | |
| Ult. Stress, psf | | | | |
| Strain, % | | | | |
| Strain rate, in./min. | 0.002 | 0.002 | 0.002 | |

Sample Type: In-Situ Density
Description:

Assumed Specific Gravity= 2.7
Remarks: Laboratory Log 7225

Plate 19

Client: NOVA Geotechnical Testing & Construction Services

Project: Testing as Ordered

Source of Sample: B-1, Luxe Locker **Depth:** 2.5

Sample Number: 1B

Proj. No.: 2248-01-1

Date Sampled: 03/22/19

DIRECT SHEAR TEST REPORT
 BLACK EAGLE CONSULTING, INC.
 Reno, Nevada

Tested By: GLO **Checked By:** LO



Silver State Labs-Reno
 1135 Financial Blvd
 Reno, NV 89502
 (775) 857-2400 FAX: (888) 398-7002
 www.ssalabs.com

Analytical Report

Workorder#: **19040008**

Date Reported: **4/5/2019**

Client: Nova Geotechnical - Reno

Sampled By: D. Lehman

Project Name: RG 19-036 / Bulk #069

PO #:

Laboratory Accreditation Number: NV015/CA2990

| | | | |
|----------------------|-------------------------|--------------------------|----------------------|
| Laboratory ID | Client Sample ID | Date/Time Sampled | Date Received |
| 19040008-01 | Bulk #069 | 03/28/2019 11:00 | 4/1/2019 |

| Parameter | Method | Result | Units | PQL | Analyst | Date/Time Analyzed | Data Flag |
|-----------------------|--------------|--------|----------|-----|---------|--------------------|-----------|
| pH | SW-846 9045D | 7.32 | pH Units | | KK | 04/04/2019 15:10 | |
| pH Temperature | SW-846 9045D | 22.0 | °C | | KK | 04/04/2019 15:10 | |
| Specific Conductivity | SM 2510B | 60 | µmhos/cm | | MA | 04/02/2019 14:21 | |
| Sulfate | EPA 9056 | 6.3 | mg/Kg | 2 | MA | 04/02/2019 16:06 | |

Job No. RG-19-036

Corrosion Report

04-19-2019



Luxe Locker - Spanish Springs
 SEC Ingenuity Ave. and Digital Ct.
 Sparks, Washoe County, Nevada

Plate No. 20

NOTES:

1. REFERENCE "GENERAL NOTES" ON SHEET C6.1
2. REFERENCE "ABBREVIATIONS" ON SHEET C6.1
3. REFERENCE "LEGEND" ON SHEET C6.1
4. ADD 4500 TO ALL FINISHED GRADE OR INVERT ELEVATIONS
5. EXISTING PARCEL LINE AND PUE TO BE RELINQUISHED WITH BOUNDARY LINE ADJUSTMENT.

CONSTRUCTION NOTES:

1. SAWCUT AS PER DETAIL 1, SHEET C6.2

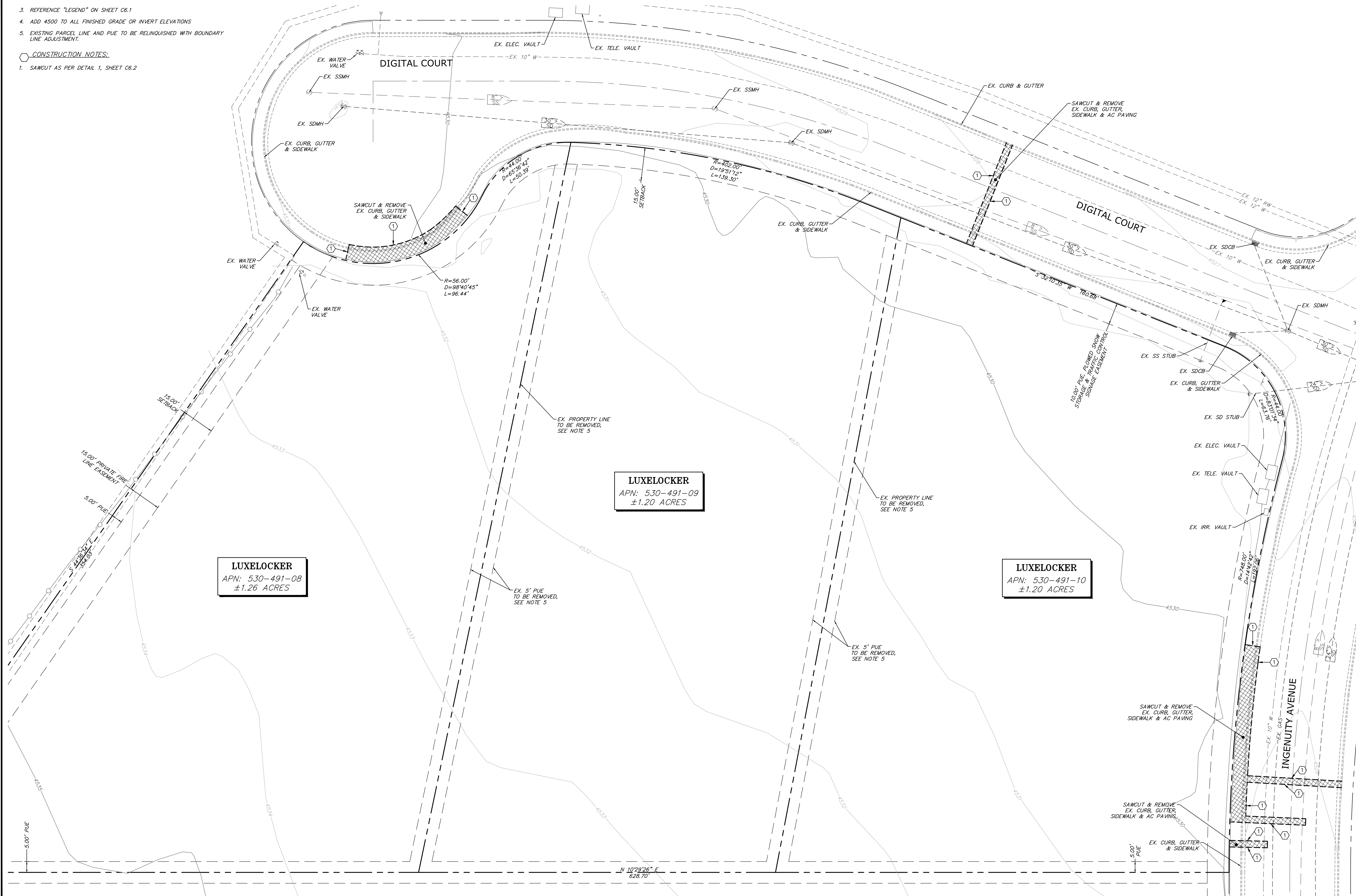

1"=20'-0" LUXELOCKER RENO 19042_C11

DEMOLITION PLAN

SCALE: 1" = 20'-0"

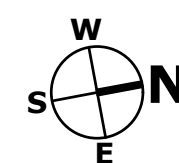

2 DAYS BEFORE
800 BIG GAIL USA
TOLL FREE 1-800-227-2600

| | | |
|-------------------|---|-------------------------------|
| COPYRIGHT: | All drawings herein are the property of Tectonics Design Group and may not be reproduced or used in any capacity without the written authorization of Tectonics Design Group. | |
| | DRAWN: | N.D.J. |
| STAMP: | CHECKED/STAMPED: | N.D.J. |
| | MATT K. RASMUSSEN, P.E. | |
| DESIGNER: | | |
| | 10/14/19 | |
| PROJECT/CLIENT: | LUXELOCKER 11455 Digital Court, Spanish Springs, Nevada Spanish Springs Storage Partners, LLC. 1845 McCulloch Blvd., Suite A6, Lake Havasu City, AZ. | |
| | # : 19042 | |
| SUBMITTAL RECORD: | DATE: | SUBMITTAL |
| | 6/24/19 | PERMIT SET |
| | 9/6/19 | PROGRESS SET |
| SHEET TITLE: | 10/14/19 | WASHOE COUNTY REVIEW COMMENTS |
| | DEMOLITION PLAN | |
| SHEET: | C1.1 | |

TECTONICS DESIGN GROUP

730 Sandhill Rd., #250, Reno, Nevada 89521
 tel: 775-824-9988
 fax: 775-824-9986
 www.tectonicsdesigngroup.com

| PROJECT LEGEND | |
|-------------------|---------------------|
| A.P.N.: | 530-491-08, 09 & 10 |
| PARCEL ZONING: | 1 (INDUSTRIAL) |
| SITE SETBACKS: | |
| FRONT YARD: | = 15 FEET |
| STREET SIDE: | = 15 FEET |
| SIDE YARD: | = 10 FEET |
| BACK YARD: | = 15 FEET |
| PARKING REQUIRED: | |
| STANDARD PARKING: | = 2 SPACE |
| VAN ACCESSIBLE: | = 1 SPACE |
| TOTAL PROVIDED: | = 3 SPACES |

- NOTES:**
- PERMANENT STRIPING, BIKE LANES, AND MARKINGS SHALL BE IN ACCORDANCE WITH THE "MANUAL ON UNIFORM TRAFFIC CONTROL DEVICES".
 - PARKING SPACE LINES SHALL BE 4-INCH WIDE, WHITE STRIPES.
 - HANDICAP PARKING SPACES SHALL BE MARKED WITH A PAINTED BLUE FIELD 48-INCHES SQUARE CONTAINING A PAINTED WHITE WHEELCHAIR SYMBOL.
 - HANDICAP PARKING AISLE LINES SHALL HAVE 4-INCH WIDE, WHITE STRIPES AT A 45 DEGREE ANGLE AND AT 18-INCHES ON CENTER.
 - PARKING STALL INSTALLATION AND MATERIALS SHALL CONFORM TO THE LATEST EDITION OF THE M.U.T.C.D. AND SECTION 330 OF THE "ORANGE BOOK".
 - ALL EXTERIOR CONCRETE EXPOSED TO FREEZING AND THAWING CONDITIONS SHOULD BE RATED AT 4,500 PSI MINIMUM.
 - REFERENCE "GENERAL NOTES" ON SHEET C6.1
 - REFERENCE "ABBREVIATIONS" ON SHEET C6.1
 - REFERENCE "LEGEND" ON SHEET C6.1
 - TOTAL DISTURBED AREA FOR SITE = ±3.31 AC

ESTIMATED EARTHWORK QUANTITIES (TO SUB-GRADE):

CUT: 2,523 CY CUT;
 FILL: 416 CY FILL;
 TOTAL: 2,107 CY EXPORT

NOTES: THESE ARE ESTIMATED QUANTITIES ONLY. CONTRACTOR IS RESPONSIBLE TO CONSTRUCT PROJECT TO LINES AND GRADES AS SHOWN ON THE PLANS.

- CONSTRUCTION NOTES:**
- CONSTRUCT CONCRETE SIDEWALK AS PER DETAIL 2, SHEET C6.2
 - CONSTRUCT 5' X 5' CONCRETE LANDING AS PER DETAIL 2, SHEET C6.2
 - CONSTRUCT MIDBLOCK ACCESSIBLE PEDESTRIAN RAMP AS PER DETAIL 3, SHEET C6.2
 - CONSTRUCT TYPE I P.C.C. MEDIAN CURB AS PER DETAIL 6, SHEET C6.2
 - INSTALL ACCESSIBLE PARKING STALL AS PER DETAIL 7, SHEET C6.2
 - CONSTRUCT CMU TRASH ENCLOSURE, SEE ARCHITECTURAL PLANS FOR DESIGN INFORMATION
 - CONSTRUCT CONCRETE APRON AS PER DETAIL 8, SHEET C6.2
 - CONSTRUCT BITUMINOUS PAVEMENT PATCH AS PER DETAIL 2 & 3, SHEET C6.3
 - CONSTRUCT 6" WIDE P.C.C. LONGITUDINAL VALLEY GUTTER 4, SHEET C6.3
 - INSTALL TYPE R1-1 30" STOP SIGN AS PER DETAIL 5 & 6, SHEET C6.3
 - CONSTRUCT STOP BAR AS PER MUTCD
 - CONSTRUCT 3' WIDE VALLEY GUTTER AS PER DETAIL 5, SHEET C6.2
 - INSTALL TRANSFORMER & PAD, COORDINATE FINAL LOCATION WITH NV ENERGY
 - CONSTRUCT 4" MAN GATE, SEE ARCHITECTURAL PLANS FOR DESIGN INFORMATION
 - CONSTRUCT CMU PILASTER, SEE ARCHITECTURAL PLANS FOR DESIGN INFORMATION
 - CONSTRUCT CMU PRIVACY WALL, SEE ARCHITECTURAL PLANS FOR DESIGN INFORMATION
 - CONSTRUCT SLIDING GATE, SEE ARCHITECTURAL PLANS FOR DETAIL 4, SHEET C6.2
 - CONSTRUCT AC PAVING AS PER DETAIL 3, SHEET C6.6

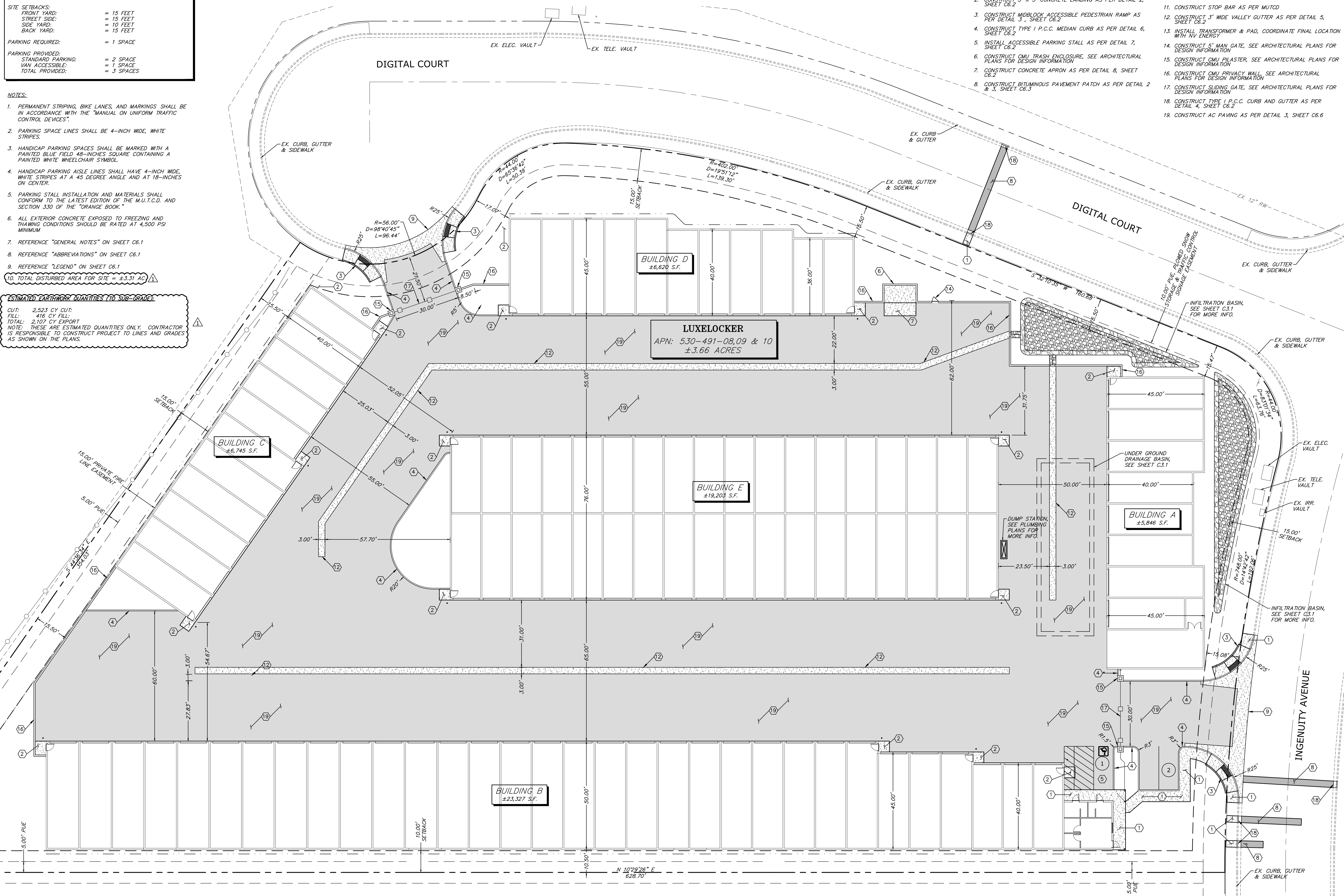

SITE PLAN
 SCALE: 1" = 20'-0"



COPYRIGHT: DRAWN: N.D.J.
 DESIGNED: N.D.J.
 CHECKED/STAMPED: MATT K. RASMUSSEN, P.E.

10/14/19

TECTONICS DESIGN GROUP

730 Sandhill Rd., #250, Reno, Nevada 89521
 tel: 775-824-9988
 fax: 775-824-9986
 www.tectonicsdesigngroup.com

LUXELOCKER
 11455 Digital Court, Spanish Springs, Nevada
Spanish Springs Storage Partners, LLC.
 1845 McCulloch Blvd., Suite A6, Lake Havasu City, AZ.

PROJECT/CLIENT: # 19042

| DATE: | SUBMITTAL: |
|----------|-------------------------------|
| 6/24/19 | PERMIT SET |
| 9/6/19 | PROGRESS SET |
| 10/14/19 | WASHOE COUNTY REVIEW COMMENTS |

SHEET TITLE: SITE PLAN

SHEET: 2 DAYS BEFORE 100 BIRCH CANYON TOLL FREE 1-800-227-2600

C2.1

EROSION CONTROL NOTES:

1. INSTALL SEDIMENT FENCE AND PERIMETER EROSION CONTROL MEASURES PRIOR TO BEGINNING CONSTRUCTION.
2. LEAVE NATIVE VEGETATION UNDISTURBED OUTSIDE AREAS OF CONSTRUCTION.
3. MODIFY EROSION CONTROL METHODS AS REQUIRED DUE TO WEATHER OR CONSTRUCTION CHANGES.
4. LOCATION OF ESCP FACILITIES SHOWN ARE APPROXIMATE. ALL FACILITIES TO BE FIELD PLACED PER CONSTRUCTION REQUIREMENTS.
5. CONTRACTOR TO MECHANICALLY REMOVE SEDIMENT FROM ROAD AND SHALL NOT WASH IT DOWN STORM SEWERS.

NOTES:

1. REFERENCE "GENERAL NOTES" ON SHEET C6.1
2. REFERENCE "ABBREVIATIONS" ON SHEET C6.1
3. REFERENCE "LEGEND" ON SHEET C6.1
4. ADD 4500 TO ALL FINISHED GRADE OR INVERT ELEVATIONS

CONSTRUCTION NOTES:

1. INSTALL R-TANK TRIPLE MODULE SUBSURFACE STORAGE SYSTEM AS PER SHEET C3.2
2. CONSTRUCT INFILTRATION BASIN AS PER DETAIL 4, SHEET C6.6
3. CONSTRUCT RIP RAP LINED DRAINAGE SWALE AS PER DETAIL 5, SHEET C6.6
4. INSTALL GRATE IN FACE OF CMU AS PER DETAIL 6, SHEET C6.6. GRATE WILL BE INSTALLED IN CMU TO ALLOW WATER TO DRAIN THRU TO INFILTRATION BASIN.

BASIS OF BEARING:

NORTH WAS ESTABLISHED WITH GPS OBSERVATIONS (NEVADA STATE PLANE COORDINATES, WEST ZONE, NAD83) OF NDOT MONUMENT "1533002", WHICH HAS WHICH HAS COORDINATES PUBLISHED ONLINE BY THE NEVADA DEPARTMENT OF TRANSPORTATION.

BASIS OF ELEVATION:

THE VERTICAL DATUM FOR THIS SURVEY WAS ESTABLISHED USING GPS OBSERVATIONS OF NDOT MONUMENT "1533002", WHICH HAS AN ELEVATION OF 4555.71 FEET (NAVD88) ACCORDING TO DATA PUBLISHED BY THE NEVADA DEPARTMENT OF TRANSPORTATION.

BASIN VOLUME TABLE

| | 100 YR Required Volume (c.f.) | 100 YR Provided Volume (c.f.) |
|---------|--|--|
| Basin 1 | 10,542 | 10,524 |

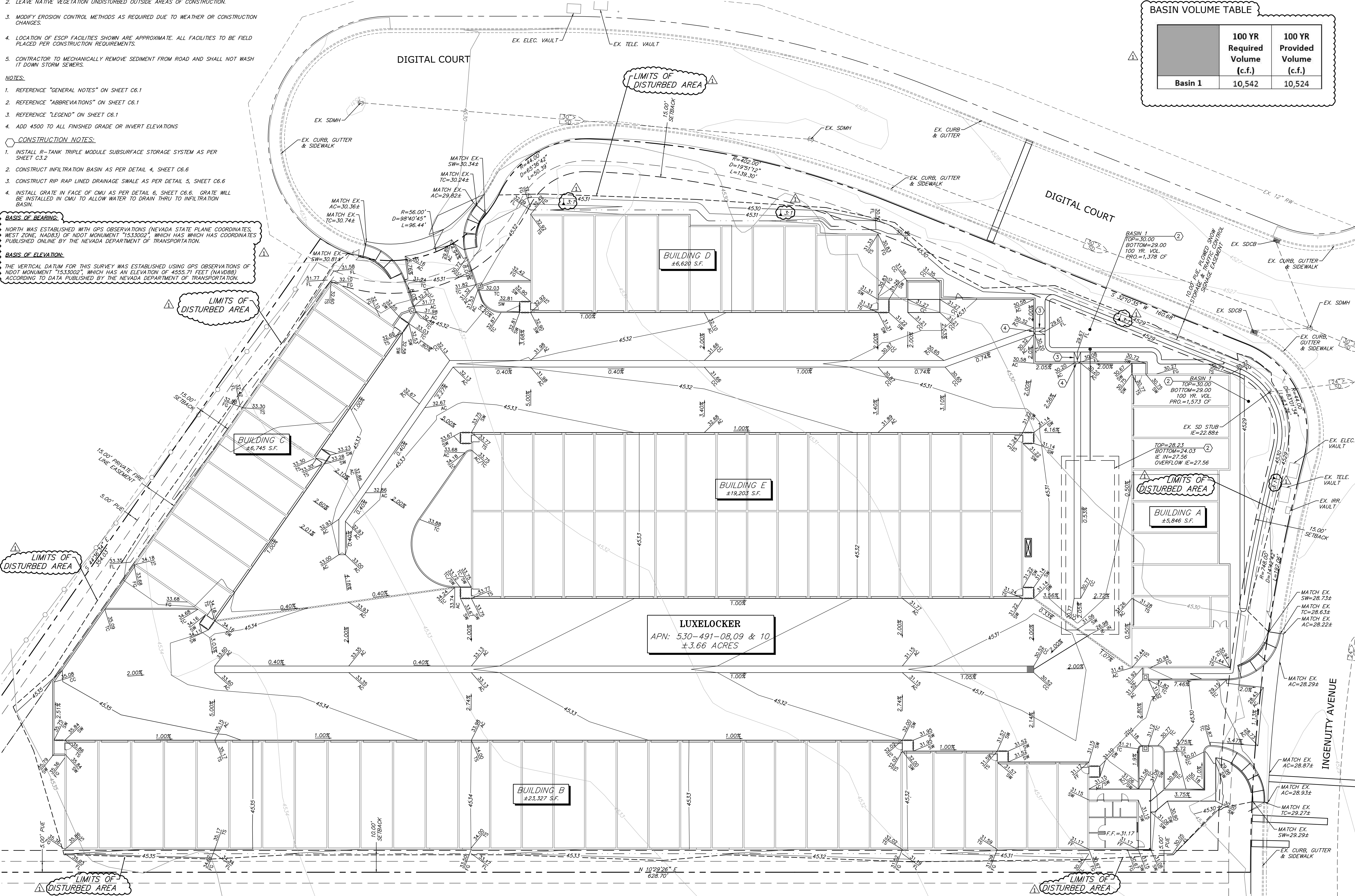

GRADING PLAN

SCALE: 1" = 20'-0"



COPYRIGHT: DRAWN: N.D.J.
DESIGNED: N.D.J.
CHECKED/STAMPED: MATT K. RASMUSSEN, P.E.
10/14/19

TECTONICS DESIGN GROUP
730 Sandhill Rd., #250, Reno, Nevada 89521
tel: 775-824-9988
fax: 775-824-9986
www.tectonicsdesigngroup.com

LUXELOCKER
11455 Digital Court, Spanish Springs, Nevada
Spanish Springs Storage Partners, LLC.
1845 McCulloch Blvd., Suite A6, Lake Havasu City, AZ.

PROJECT/CLIENT: # 19042

| | |
|---------------|-------------------------------|
| DATE: 6/24/19 | SUBMITTAL PERMIT SET |
| 9/6/19 | PROGRESS SET |
| 10/14/19 | WASHOE COUNTY REVIEW COMMENTS |

SUBMITTAL RECORD: SHEET TITLE: GRADING PLAN

C3.1

1"=20'-0" LUXELOCKER RENO 19042_C31

NOTES:

1. REFERENCE "GENERAL NOTES" ON SHEET C6.1
2. REFERENCE "ABBREVIATIONS" ON SHEET C6.1
3. REFERENCE "LEGEND" ON SHEET C6.1
4. ADD 4500 TO ALL FINISHED GRADE OR INVERT ELEVATIONS
5. ALL SLOPES GREATER THAN 3:1 SHALL BE TREATED WITH 0.5' DEEP 6"-8" ROCK RIPRAP

CONSTRUCTION NOTES:

1. INSTALL R-TANK TRIPLE MODULE SUBSURFACE STORAGE SYSTEM AS PER DETAIL 1, SHEET C3.2

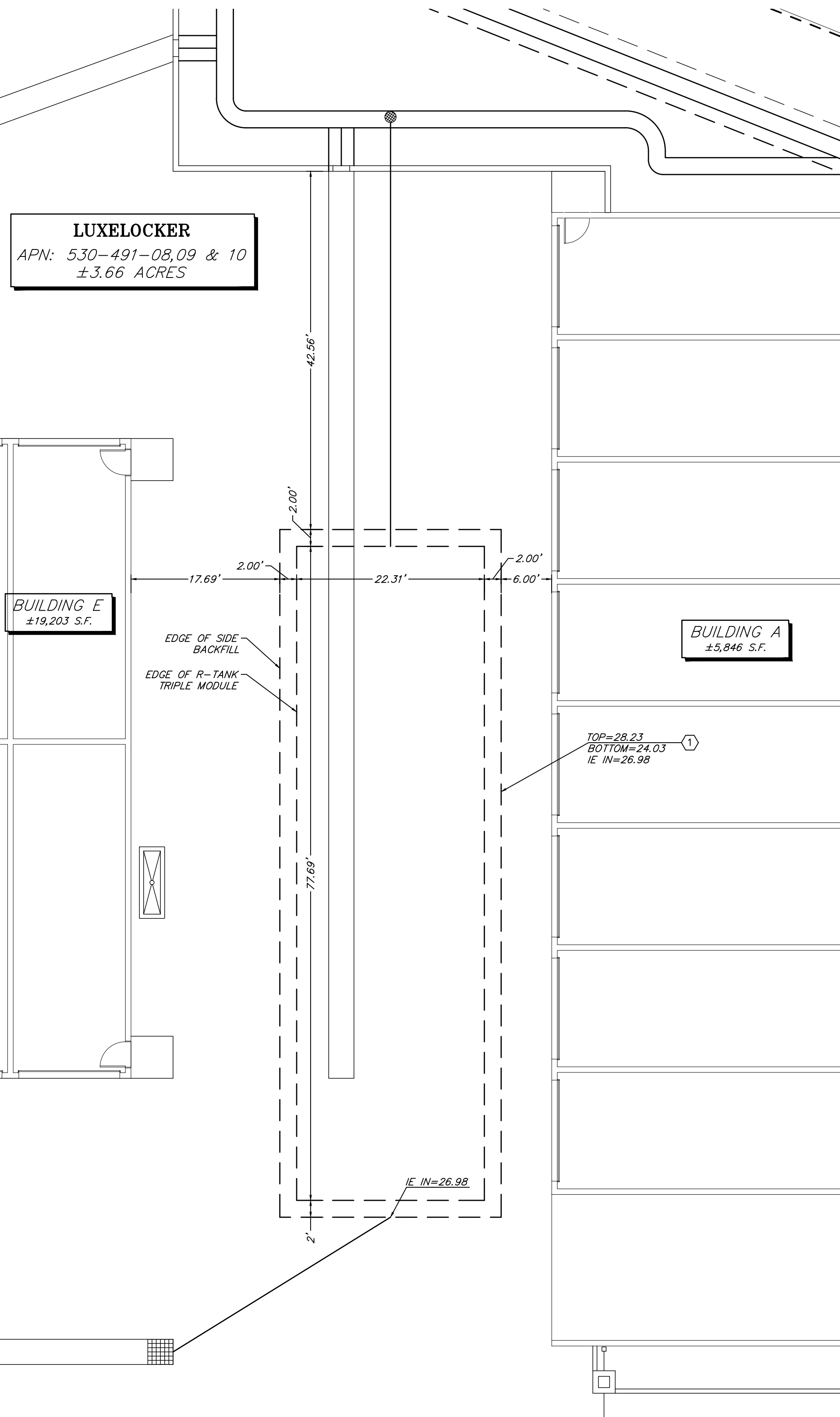

SUBSURFACE STORAGE SYSTEM PLAN

SCALE: 1" = 10'-0"

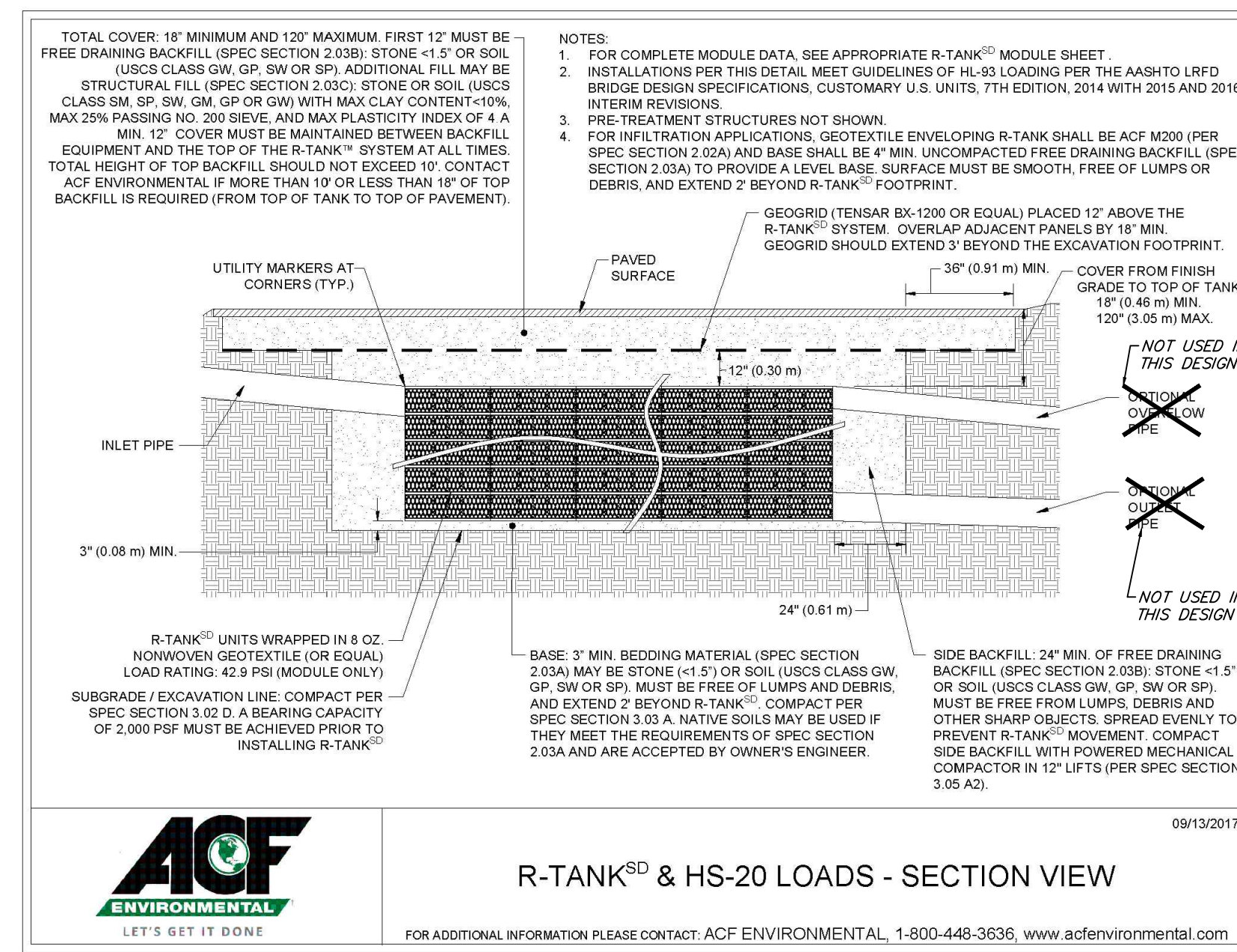

R-TANK SD & HS-20 LOADS - SECTION VIEW

1 R-TANK SUBSURFACE STORAGE SYSTEM DETAIL

SCALE: N.T.S.

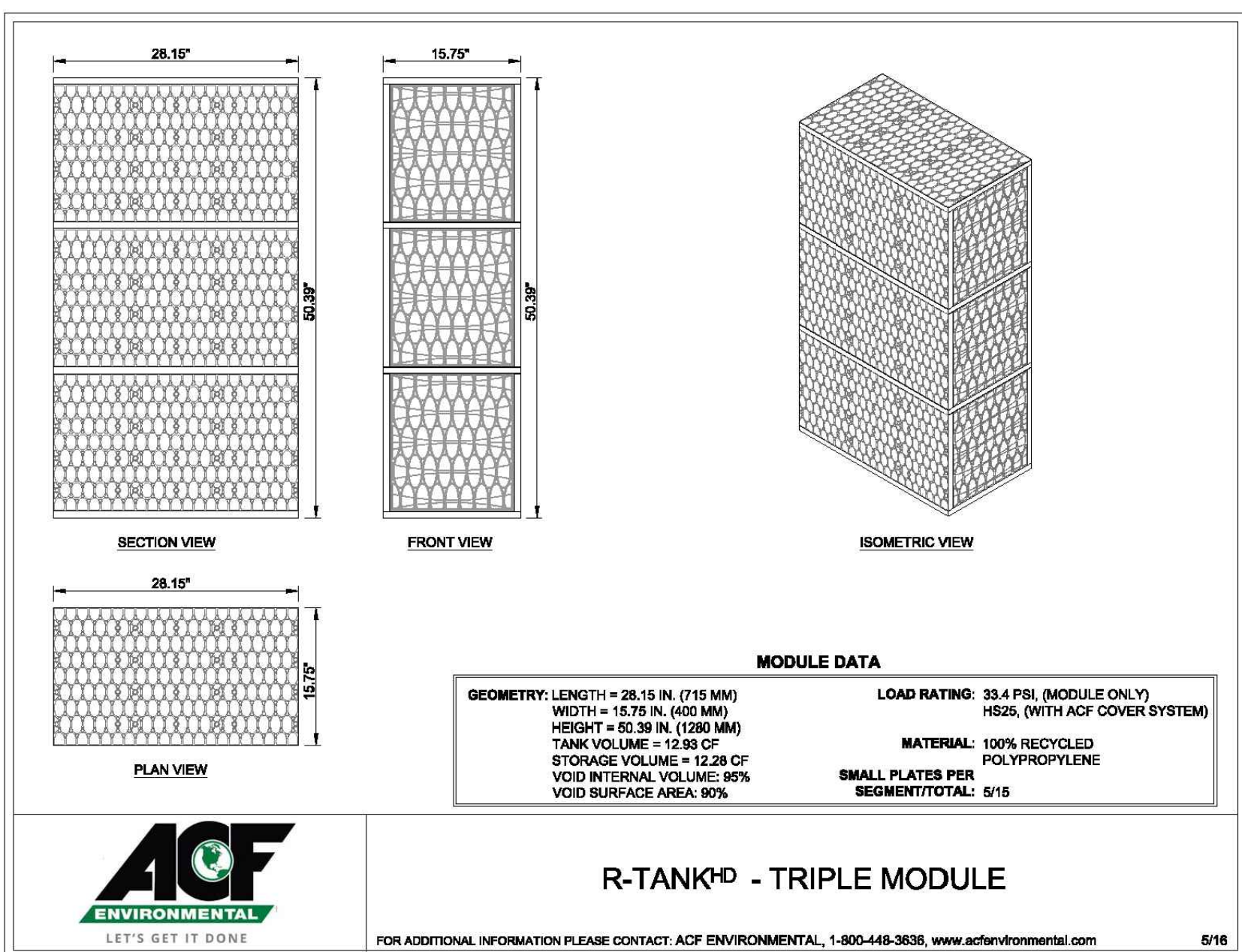

R-TANK HD - TRIPLE MODULE

3 R-TANK TRIPLE MODULE DETAIL

SCALE: N.T.S.

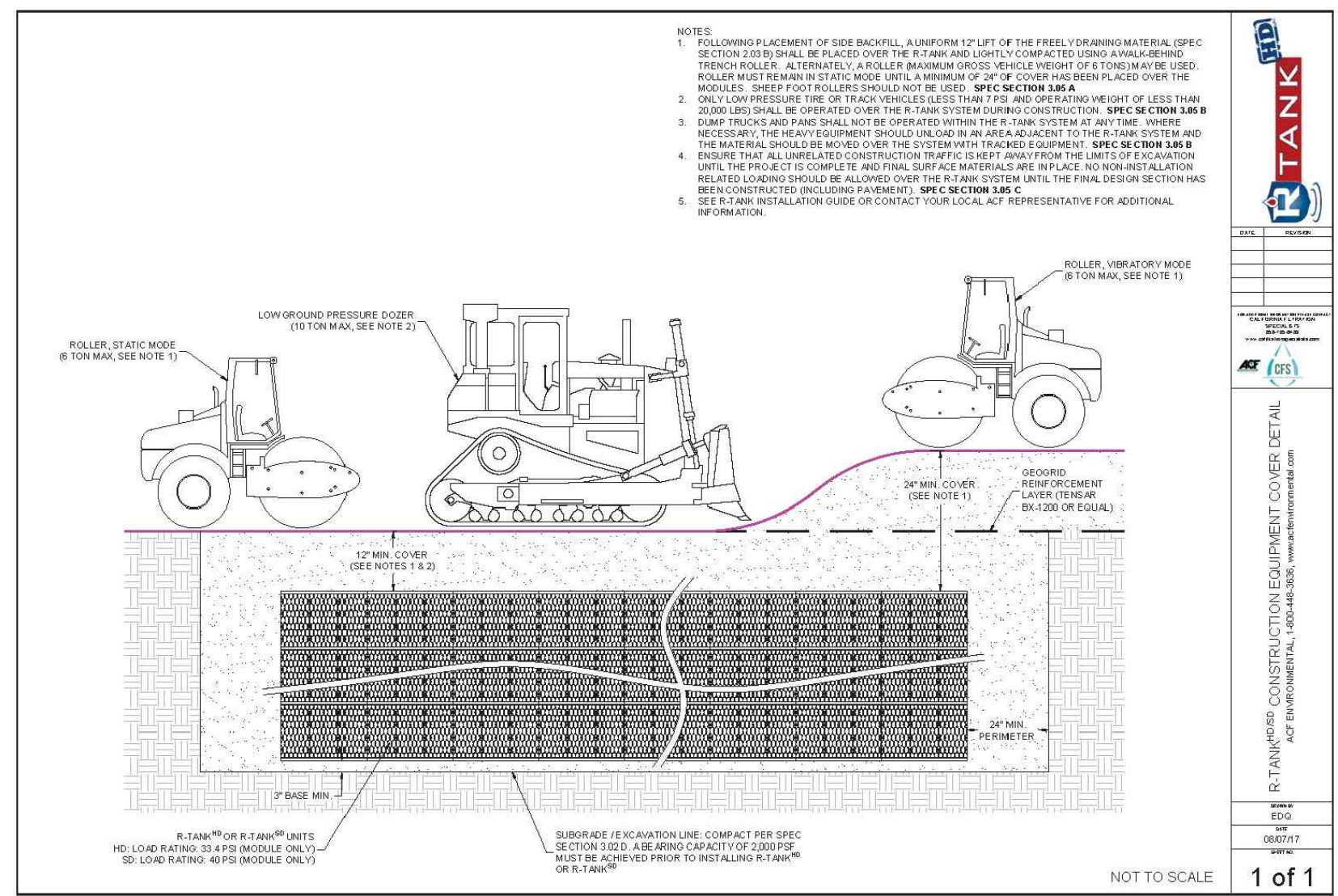

5 R-TANK CONSTRUCTION COVER DETAIL

SCALE: N.T.S.

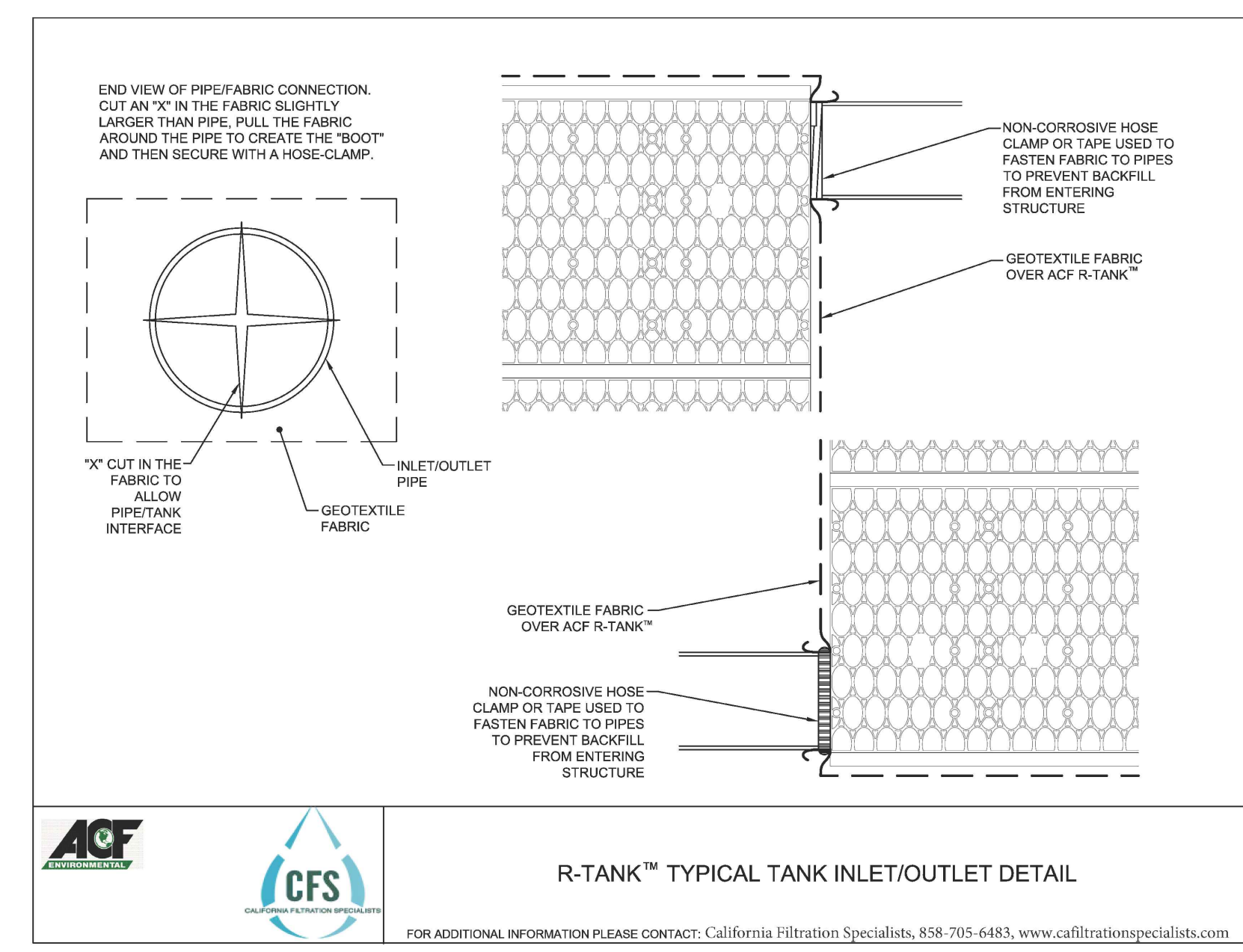

R-TANK TYPICAL TANK INLET/OUTLET DETAIL

2 INLET / OUTLET CONNECTION DETAIL

SCALE: N.T.S.

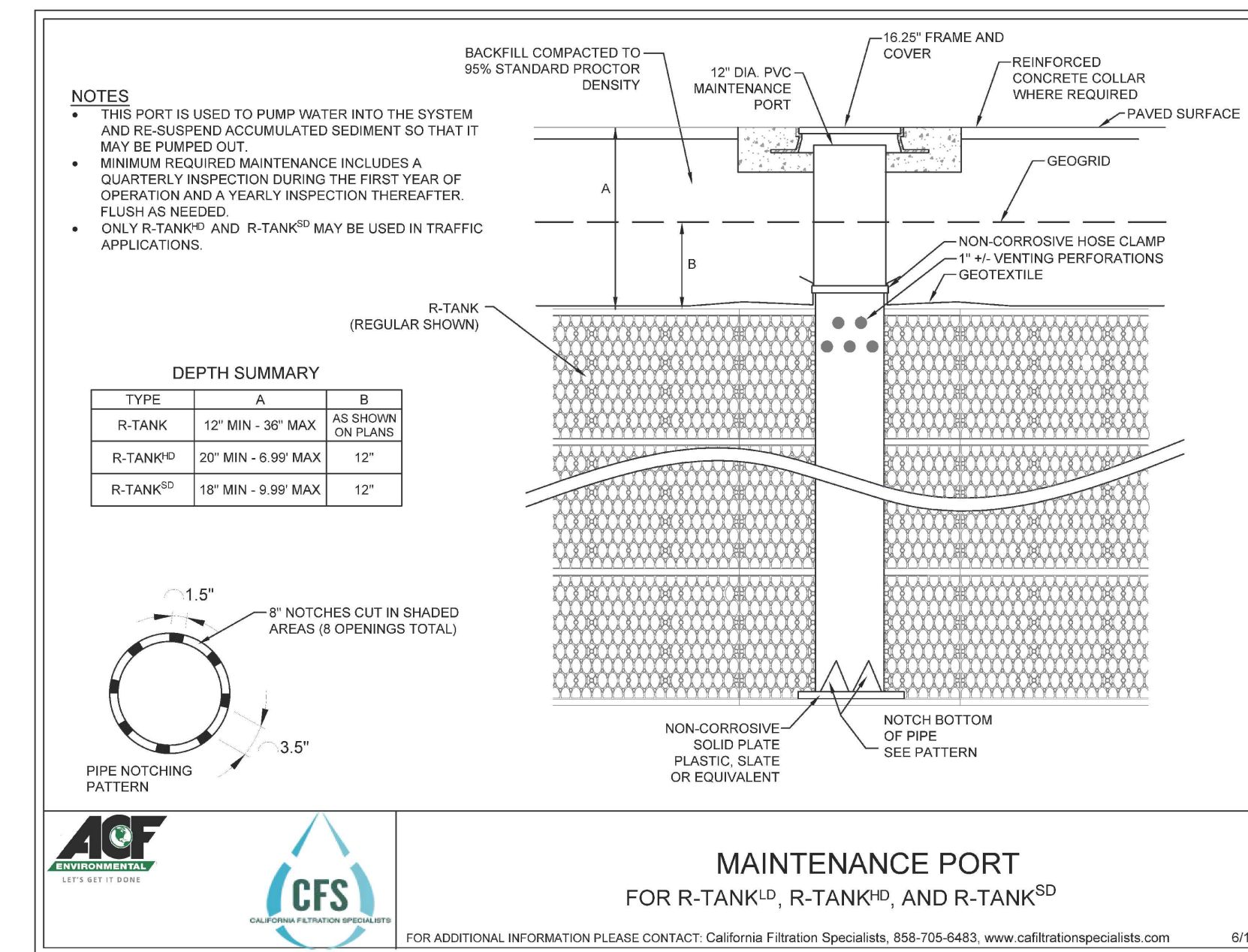

MAINTENANCE PORT FOR R-TANK SD, R-TANK HD, AND R-TANK SDD

4 MAINTENANCE PORT DETAIL

SCALE: N.T.S.

1" = 20'-0" LUXELOCKER RENO 19042_C32

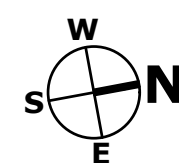

All drawings herein are the property of Tectonics Design Group and may not be reproduced or used in any capacity without the written authorization of Tectonics Design Group.
 DRAWN: N.D.J.
 DESIGNED: N.D.J.
 CHECKED/STAMPED: MATT K. RASMUSSEN, P.E.

 10/14/19
TECTONICS DESIGN GROUP
 730 Sandhill Rd., #250, Reno, Nevada 89521
 Tel: 775-824-9988
 Fax: 775-824-9966
 www.tectonicsdesigngroup.com
LUXELOCKER
 11455 Digital Court, Spanish Springs, Nevada
Spanish Springs Storage Partners, LLC.
 1845 McCulloch Blvd., Suite A6, Lake Havasu City, AZ.
 PROJECT/CLIENT: # 19042
 DATE: 6/24/19 SUBMITTAL
 9/6/19 PERMIT SET
 10/14/19 WASHOE COUNTY REVIEW COMMENTS
 SHEET TITLE: SUBSURFACE STORAGE SYSTEM PLAN & DETAILS
C3.2

CONSTRUCTION NOTES:

- CONTRACTOR SHALL POT-HOLE AND VERIFY EXACT LOCATION OF UTILITY PRIOR TO THE CONSTRUCTION OF ANY IMPROVEMENTS. CONTRACTOR SHALL NOTIFY ENGINEER OF ANY CONFLICTS FOUND IN THE FIELD.
- CONSTRUCT SEWER & STORM DRAIN TRENCH EXCAVATION & BACKFILL AS PER DETAIL 7, SHEET C6.3
- CONNECT TO EXISTING SANITARY SEWER STUB
- CONSTRUCT 6" SDR 35 PVC SANITARY SEWER LATERAL AS PER DETAIL 1, SHEET C6.4. LENGTH AND SLOPE AS SHOWN ON PLANS.
- CONSTRUCT 4" SDR 35 PVC SANITARY SEWER LATERAL AS PER DETAIL 1, SHEET C6.4. LENGTH AND SLOPE AS SHOWN ON PLANS.
- CONSTRUCT SANITARY SEWER CLEAN OUT AS PER DETAIL 2, SHEET C6.4
- FOR INTERNAL CONTINUATION OF SANITARY SEWER, SEE PLUMBING PLANS
- INSTALL TYPE 3R 36" x 36" CATCH BASIN AS PER DETAIL 5, SHEET C6.4
- INSTALL 10" SDR 35 PVC STORM DRAIN PIPE, LENGTH AND SLOPE AS SHOWN ON PLANS
- NOT USED
- NOT USED
- CONSTRUCT WATER TRENCH EXCAVATION & BACKFILL AS PER DETAIL 6, SHEET C6.3
- CONSTRUCT FIRE HYDRANT ASSEMBLY AS PER DETAIL 2, SHEET C6.5. INSTALL 75 LF 6" DR 14-CL-305 PVC & USE ROMAC SSTIII STAINLESS STEEL TAPPING SLEEVE
- NOT USED
- NOT USED
- NOT USED
- NOT USED
- NOT USED
- NOT USED
- NOT USED
- NOT USED
- NOT USED
- CONSTRUCT 1.5" DOMESTIC WATER SERVICE, SEE TMWA PLANS FOR DESIGN INFORMATION
- CONSTRUCT DOMESTIC WATER SERVICE METER & BACKFLOW, SEE TMWA PLANS FOR DESIGN INFORMATION
- INSTALL 1.5" HDPE DOMESTIC WATER SERVICE, LENGTH AS SHOWN ON PLANS
- INSTALL 1" HDPE DOMESTIC WATER SERVICE, LENGTH AS SHOWN ON PLANS
- FOR INTERNAL CONTINUATION OF DOMESTIC WATER SERVICE, SEE PLUMBING PLANS
- CONSTRUCT 1.5" RECLAIMED WATER SERVICE TAP AS PER DETAIL 1 & 2, SHEET C6.6
- INSTALL 1.5" RECLAIMED SERVICE WATER METER AS PER DETAIL 6, SHEET C6.5
- CONSTRUCT GAS SERVICE, COORDINATE FINAL SIZE & LOCATION WITH NV ENERGY
- INSTALL 15" SDR 35 PVC STORM DRAIN PIPE, LENGTH AND SLOPE AS SHOWN ON PLANS
- CONSTRUCT RECLAIMED WATER SERVICE TRENCH AS PER DETAIL 7, SHEET C6.5
- INSTALL 1.5" HDPE RECLAIMED WATER SERVICE, LENGTH AS SHOWN ON PLANS
- FOR CONTINUATION OF RECLAIMED WATER SERVICE, SEE LANDSCAPE PLANS
- DUMP STATION, SEE PLUMBING PLANS FOR MORE INFORMATION
- INSTALL YARD HYDRANT, SEE PLUMBING PLANS FOR MORE INFORMATION
- CONSTRUCT FIRE HYDRANT ASSEMBLY AS PER DETAIL 2, SHEET C6.5. INSTALL 70 LF 6" DR 14-CL-305 PVC 20 LF 6" MRJ-DIP & USE ROMAC SSTIII STAINLESS STEEL TAPPING SLEEVE
- INSTALL 8" SDR 35 PVC STORM DRAIN PIPE, LENGTH AND SLOPE AS SHOWN ON PLANS
- CONSTRUCT BASIN OUTLET AS PER DETAIL 7, SHEET C6.7

NOTES:

- REFERENCE "GENERAL NOTES" ON SHEET C6.1
- REFERENCE "ABBREVIATIONS" ON SHEET C6.1
- REFERENCE "LEGEND" ON SHEET C6.1
- ADD 4500 TO ALL FINISHED GRADE OR INVERT ELEVATIONS

CROSSING NOTES:

- 6" HYDRANT LATERAL CROSSING EXISTING 24" STORM DRAIN MAIN FINISHED GRADE ELEVATION=29.00±
6" HYDRANT LATERAL BOTTOM OF PIPE=25.33±
EXISTING 24" STORM DRAIN MAIN TOP OF PIPE=24.65±
FIELD VERIFY ELEVATIONS & MAINTAIN 18" MINIMUM VERTICAL CLEARANCE.
- 6" HYDRANT LATERAL CROSSING EXISTING 8" SEWER MAIN FINISHED GRADE ELEVATION=29.00±
6" HYDRANT LATERAL BOTTOM OF PIPE=25.33±
EXISTING 24" STORM DRAIN MAIN TOP OF PIPE=21.55±
FIELD VERIFY ELEVATIONS & MAINTAIN 18" MINIMUM VERTICAL CLEARANCE.
- 6" HYDRANT LATERAL CROSSING EXISTING 10" WATER MAIN EXISTING GRADE ELEVATION=27.98±
6" HYDRANT LATERAL BOTTOM OF PIPE=24.38±
EXISTING 10" WATER MAIN TOP OF PIPE=22.29±
FIELD VERIFY ELEVATIONS & MAINTAIN 18" MINIMUM VERTICAL CLEARANCE.
- 6" FIRE HYDRANT LATERAL CROSSING EXISTING 8" SEWER MAIN FINISHED GRADE ELEVATION=27.98±
6" HYDRANT LATERAL BOTTOM OF PIPE=24.40±
EXISTING 8" SEWER MAIN TOP OF PIPE=21.29±
FIELD VERIFY ELEVATIONS & MAINTAIN 18" MINIMUM VERTICAL CLEARANCE.
- 6" FIRE HYDRANT LATERAL CROSSING EXISTING 30" STORM DRAIN MAIN FINISHED GRADE ELEVATION=27.94±
EXISTING 30" STORM DRAIN BOTTOM OF PIPE=22.98±
6" HYDRANT LATERAL TOP OF PIPE=21.98±
FIELD VERIFY ELEVATIONS & INSTALL 20 LF OF 6" MRJ-DIP

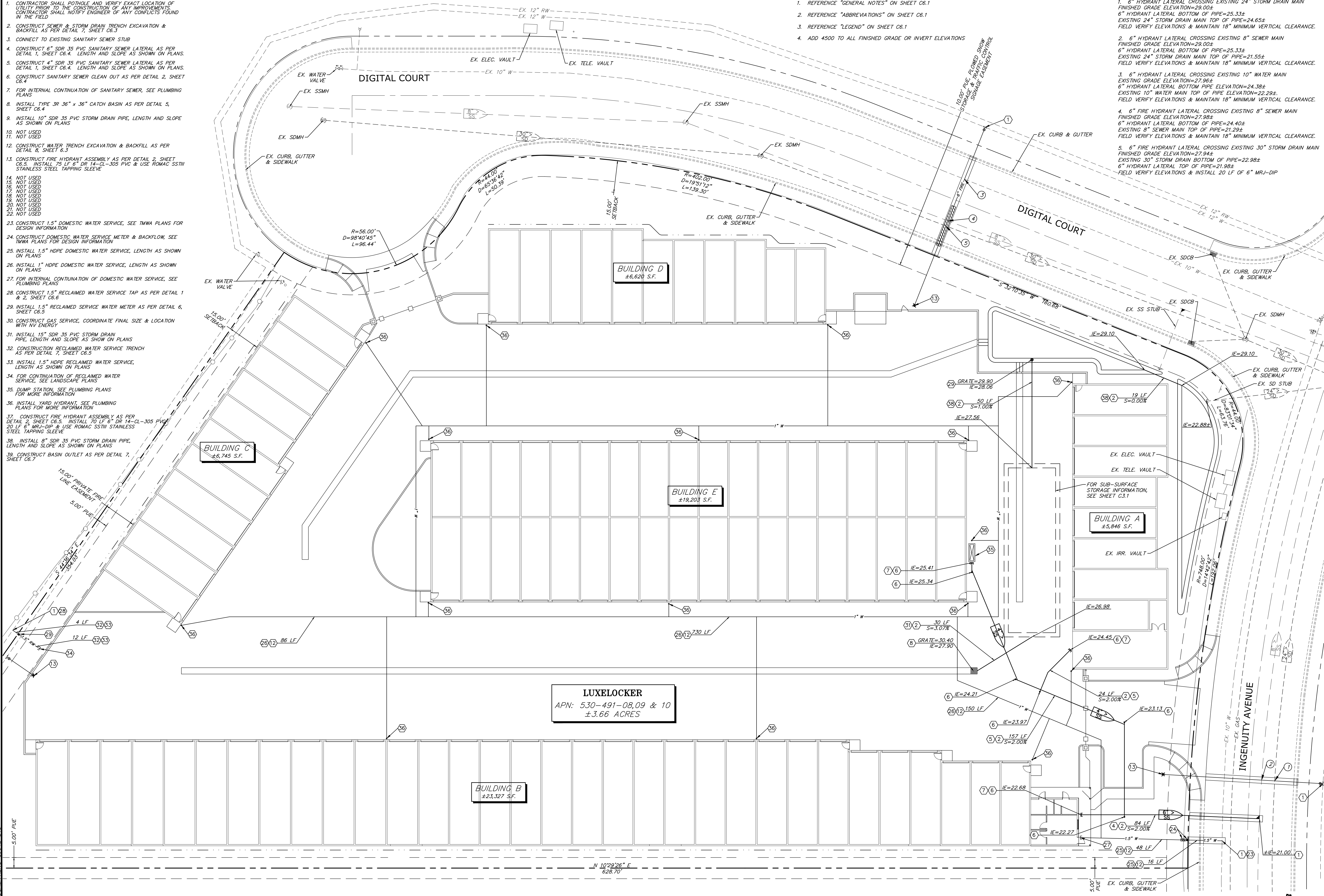

UTILITY PLAN
SCALE: 1" = 20'-0"

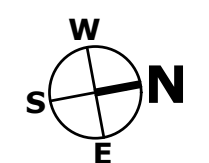

COPYRIGHT: All drawings herein are the property of Tectonics Design Group and may not be reproduced or used in any capacity without the written authorization of Tectonics Design Group.

DRAWN: N.D.J.
DESIGNED: N.D.J.
CHECKED/STAMPED: MATT K. RASMUSSEN, P.E.

10/14/19

DESIGNER: **TECTONICS DESIGN GROUP**

730 Sandhill Rd., #250, Reno, Nevada 89521
tel: 775-824-9988
fax: 775-824-9986
www.tectonicsdesigngroup.com

PROJECT/CLIENT: **LUXELOCKER**
11455 Digital Court, Spanish Springs, Nevada
Spanish Springs Storage Partners, LLC.
1845 McCulloch Blvd., Suite A6, Lake Havasu City, AZ.

#: 19042

| | |
|----------------|-------------------------------|
| DATE: 6/24/19 | SUBMITTAL PERMIT SET |
| DATE: 9/6/19 | PROGRESS SET |
| DATE: 10/14/19 | WASHOE COUNTY REVIEW COMMENTS |

SHEET TITLE: **UTILITY PLAN**

SHEET: **C4.1**

All drawings herein are the property of Tectonics Design Group and may not be reproduced or used in any capacity without the written authorization of Tectonics Design Group.

DRAWN: N.D.J.
 DESIGNED: N.D.J.
 CHECKED/STAMPED: MATT K. RASMUSSEN, P.E.

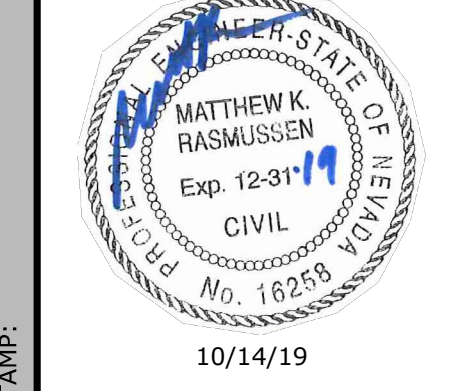

TECTONICS DESIGN GROUP
 730 Sandhill Rd., #250, Reno, Nevada 89521
 www.tectonicsdesigngroup.com
 tel: 775-824-9988
 fax: 775-824-9966

LUXELOCKER
 11455 Digital Court, Spanish Springs, Nevada
Spanish Springs Storage Partners, LLC.
 1845 McCulloch Blvd., Suite A6, Lake Havasu City, AZ.

PROJECT/CLIENT: # 19042
 DATE: 6/24/19
 SUBMITTAL RECORD: 9/6/19
 SHEET TITLE: 10/14/19

DATE: 6/24/19
 SUBMITTAL RECORD: 9/6/19
 SHEET TITLE: 10/14/19

DATE: 6/24/19
 SUBMITTAL RECORD: 9/6/19
 SHEET TITLE: 10/14/19

STORMWATER NOTES:

1. THE OWNER, SITE DEVELOPER, CONTRACTOR AND/OR THEIR AUTHORIZED AGENTS SHALL EACH DAY REMOVE ALL SEDIMENT, MUD, CONSTRUCTION DEBRIS, OR OTHER POTENTIAL POLLUTANTS THAT MAY HAVE BEEN DISCHARGED TO, OR ACCUMULATE IN, THE PUBLIC RIGHT OF WAYS OF LOGAN COUNTY AS A RESULT OF CONSTRUCTION ACTIVITIES ASSOCIATED WITH THIS SITE DEVELOPMENT OR CONSTRUCTION PROJECT. SUCH MATERIALS SHALL BE PREVENTED FROM ENTERING THE STORM SEWER SYSTEM.
2. ADDITIONAL CONSTRUCTION SITE DISCHARGE BEST MANAGEMENT PRACTICES MAY BE REQUIRED OF THE OWNER AND HIS OR HER AGENTS DUE TO UNFORSEEN EROSION PROBLEMS OR IF THE SUBMITTED PLAN DOES NOT MEET THE PERFORMANCE STANDARDS SPECIFIED BY LINCOLN COUNTY.
3. TEMPORARY OR PERMANENT STABILIZATION PRACTICES WILL BE INSTALLED ON DISTURBED AREAS AS SOON AS PRACTICABLE AND NO LATER THAN 14 DAYS AFTER THE CONSTRUCTION ACTIVITY IN THAT PORTION OF THE SITE HAS TEMPORARILY OR PERMANENTLY CEASED.
4. AT A MINIMUM, THE CONTRACTOR OR HIS AGENT SHALL INSPECT ALL DISTURBED AREAS, AREAS USED FOR STORAGE OF MATERIALS AND EQUIPMENT THAT ARE EXPOSED TO PRECIPITATION, VEHICLE ENTRANCE AND EXIT LOCATIONS AND ALL BMPs WEEKLY, PRIOR TO A FORECASTED RAIN EVENT AND WITHIN 24 HOURS AFTER ANY ACTUAL RAIN EVENT. THE CONTRACTOR OR HIS AGENT SHALL UPDATE OR MODIFY THE STORMWATER POLLUTION PREVENTION PLAN AS NECESSARY. SOME EXCEPTIONS TO WEEKLY INSPECTION MAY APPLY, SUCH AS FROZEN GROUND CONDITIONS OR SUSPENSION OF LAND DISTURBANCE ACTIVITIES.
5. ACCUMULATED SEDIMENT IN BMPs SHALL BE REMOVED WITHIN SEVEN DAYS AFTER A STORMWATER RUNOFF EVENT OR PRIOR TO THE NEXT ANTICIPATED STORM EVENT WHICHEVER IS EARLIER. SEDIMENT MUST BE REMOVED WHEN BMP DESIGN CAPACITY HAS BEEN REDUCED BY 50 PERCENT OR MORE.
6. REFER TO WEST VIRGINIA EROSION AND SEDIMENT CONTROL BEST MANAGEMENT PRACTICES MANUAL FOR FURTHER CONSTRUCTION-SITE BEST MANAGEMENT PRACTICES DEFINITIONS.

| BMP | # | SYMBOL |
|---|-------|--------|
| REVEGETATION | SS-2 | |
| WIND EROSION AND DUST CONTROL | WE-1 | |
| SILT FENCES | SC-1 | |
| STABILIZED CONSTRUCTION SITE ENTRANCE / EXITS | TC-1 | |
| STORM DRAIN OUTLET PROTECTION | SS-10 | |
| STORM DRAIN INLET PROTECTION | SC-10 | |
| STOCKPILE MANAGEMENT | WM-3 | |
| STREET SWEEPING AND VACUUMING | SC-7 | |
| SPILL PREVENTION AND CONTROL | WM-4 | |
| CONCRETE WASTE MANAGEMENT | WM-8 | |
| VEHICLE AND EQUIPMENT FUELING | NS-9 | |
| VEHICLE AND EQUIPMENT MAINTENANCE | NS-10 | |
| MATERIAL DELIVERY STORAGE | WM-1 | |
| PAVEMENT CONSTRUCTION MANAGEMENT | NS-3 | |
| GRADED FLOW DIRECTION | | |

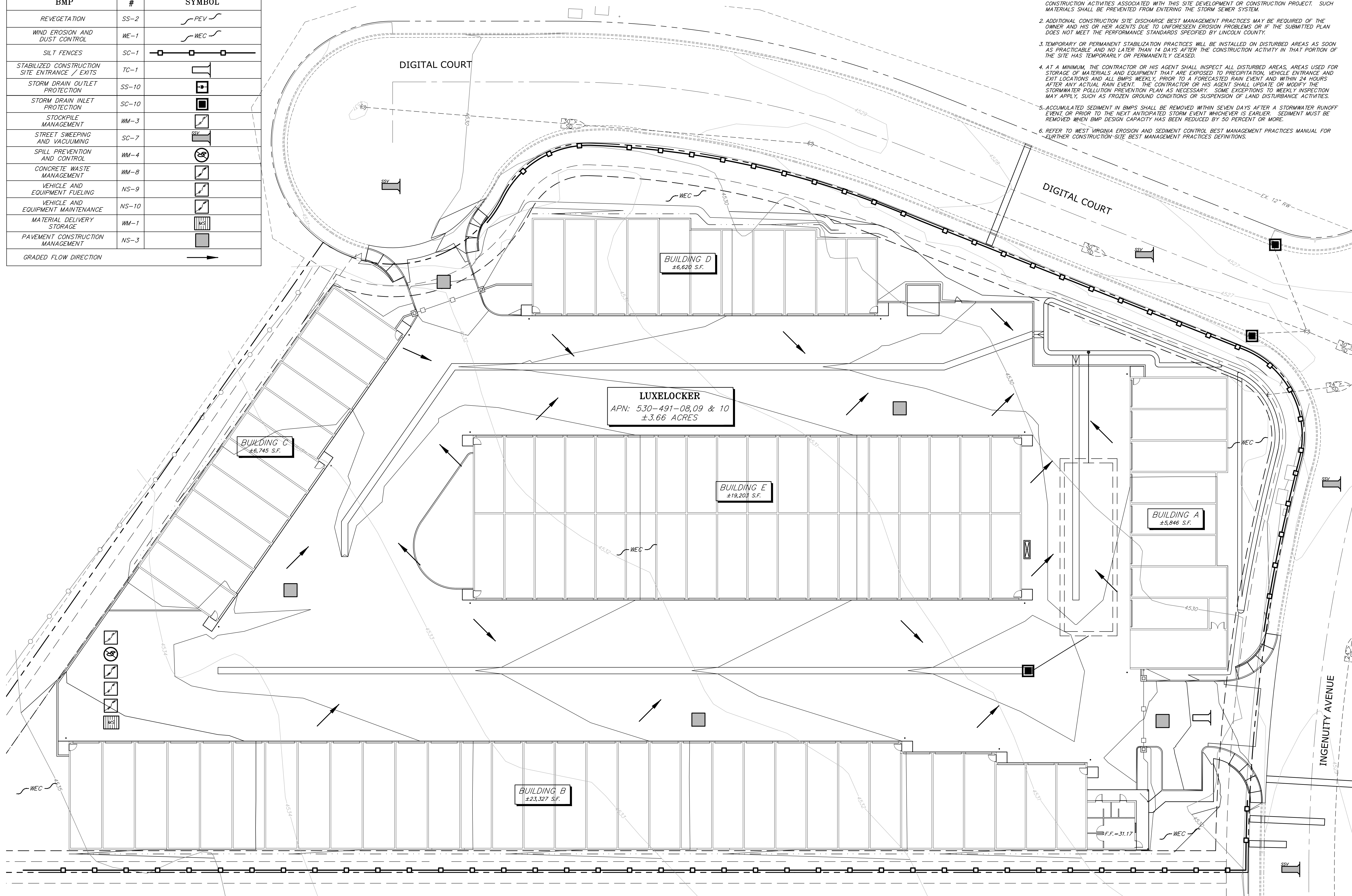

BMP PLAN
 SCALE: 1" = 20'-0"



1"=20'-0" LUXELOCKER RENO 19042_C51

C5.1

GENERAL NOTES

- ALL CONSTRUCTION AND MATERIALS SHALL CONFORM TO THE WASHOE COUNTY BOOK "STANDARD SPECIFICATIONS FOR PUBLIC WORKS CONSTRUCTION" (2013 EDITION), AND THE "STANDARD DETAILS FOR PUBLIC WORKS CONSTRUCTION," ADOPTED AND DISTRIBUTED BY THE COUNTY OF WASHOE, INCLUDING ANY ADDITIONS OR MODIFICATIONS THAT ARE SET FORTH IN THE DRAWINGS OR SPECIFICATIONS.
- ALL CONSTRUCTION SHALL MEET THE WASHOE COUNTY PUBLIC WORKS DESIGN MANUAL.
- A SOILS REPORT HAS BEEN PREPARED THROUGH A PROGRAM OF SUBSURFACE INVESTIGATION BY BLACK EAGLE CONSULTING, INC DATED JANUARY 29, 2019, DEVCON CONSTRUCTION INC., ISIDOR COURT SITE. RESULTS OF THE INVESTIGATION, ALONG WITH ITS RECOMMENDATIONS WILL BECOME PART OF THE SPECIFICATIONS, BUT DO NOT CONSTITUTE A GUARANTEE OF THE SUBSURFACE CONDITIONS IN ANY WAY.
- THE CONTRACTOR SHALL ASSUME SOLE AND COMPLETE RESPONSIBILITY FOR JOB SITE CONDITIONS DURING THE COURSE OF CONSTRUCTION FOR THIS PROJECT, INCLUDING SAFETY OF ALL PERSONS AND PROPERTY, THAT THIS REQUIREMENT SHALL APPLY CONTINUOUSLY, AND INCLUDE BOTH NORMAL WORKING HOURS AND NON-WORKING HOURS; AND THAT THE CONTRACTOR SHALL DEFEND, INDEMNIFY, AND HOLD THE OWNER, DEVELOPER AND ENGINEER HARMLESS FROM ANY AND ALL LIABILITY, REAL OR ALLEGED, IN CONNECTION WITH THE PERFORMANCE OF WORK ON THIS PROJECT, EXCEPTING FOR LIABILITY ARISING FROM THE SOLE NEGLIGENCE OF THE OWNER OR THE ENGINEER.
- THE CONTRACTOR SHALL BE RESPONSIBLE FOR ALL EXCAVATION AND SHORING PROCEDURES AND CONFORM TO THE LATEST O.S.H.A. REQUIREMENTS.
- THE CONTRACTOR SHALL MAINTAIN AN ON-GOING DUST CONTROL PROGRAM, INCLUDING WATERING OF OPEN AREAS, IN ORDER TO CONFORM WITH THE LATEST FEDERAL, STATE, AND COUNTY AIR POLLUTION REGULATIONS. THE CONTRACTOR SHALL SUBMIT FOR APPROVAL, A DUST CONTROL PLAN TO WASHOE COUNTY COMMUNITY RELATIONS & PUBLIC WORKS DEPARTMENT & NOISE AIR POLLUTION CONTROL DIVISION PRIOR TO COMMENCEMENT OF ANY WORK. CONTRACTOR SHALL PROVIDE 24 HOURS DUST CONTROL. CONTRACTORS SHALL MAKE SURE THAT THERE IS NOT DUST BLOWING ACROSS COUNTY STREETS.
- THE CONTRACTOR SHALL BE RESPONSIBLE FOR DAILY REMOVAL OF ALL CONSTRUCTION MATERIALS LOST ON PAVED STREETS, ONSITE OR OFFSITE. AT THE CLOSE OF EACH DAY THE CONTRACTOR SHALL LEAVE THE SITE AND OFFSITE AREAS IN A CLEAN AND ORDERLY FASHION. ALL DEBRIS SHALL BE REMOVED FROM THE SITE OR PLACED IN A GARBAGE RECEPTACLE.
- THE CONTRACTOR SHALL PURSUE THE WORK IN A CONTINUOUS AND DILIGENT MANNER, CONFORMING TO ALL THE PERTINENT SAFETY REGULATIONS, TO INSURE A TIMELY COMPLETION OF THE PROJECT.
- THE CONTRACTOR SHALL NOTIFY THE DESIGN PROFESSIONAL, ALL GOVERNING AGENCIES HAVING JURISDICTION OVER THE WORK, UTILITY COMPANIES, TELEPHONE COMPANIES, CABLE TELEVISION COMPANIES, AND ARIK HOES ENTITY PRIOR TO THE WORK 48 HOURS PRIOR TO BEGINNING CONSTRUCTION. THE CONTRACTOR SHALL GIVE 24 HOURS PRIOR NOTICE FOR ALL CONSTRUCTION STAKING AND INSPECTIONS REQUIRED DURING CONSTRUCTION.
- ALL AREAS DISTURBED AND LEFT UNDEVELOPED FOR A PERIOD OF MORE THAN 30 DAYS SHALL BE STABILIZED BY THE APPLICATION OF AN APPROVED DUST PALLIATIVE AT NO EXPENSE TO THE OWNER.
- THE CONTRACTOR SHALL OBTAIN AND PAY ALL FEES REQUIRED TO SECURE ANY AND ALL PERMITS NECESSARY TO PERFORM WORK WITHIN THE PUBLIC RIGHT-OF-WAY.
- ALL UTILITY LOCATIONS, SIZES, AND DESCRIPTIONS AS SHOWN ARE FROM SURFACE OBSERVATIONS USED IN CONJUNCTION WITH REFERENCE MAPS, DRAWINGS, AND VERBAL STATEMENTS SUPPLIED BY UTILITY COMPANIES, AND MAY NOT BE WHOLLY ACCURATE OR RELIABLE. IT IS THE CONTRACTOR'S RESPONSIBILITY TO VERIFY ALL UTILITIES IN THE FIELD EITHER BY ACTUAL POT-HOLING OR VISUALLY, AND NOTIFY THE ENGINEER OF ANY DISCREPANCIES. THE CONTRACTOR SHALL NOTIFY ALL UTILITY COMPANIES WHICH MAY BE AFFECTED BY THE WORK TO OBTAIN ASSISTANCE IN THE LOCATION OF EXISTING MAINS AND SERVICE CONNECTIONS. THE CONTRACTOR SHALL ALSO CALL U.S.A. DIG (1-800-227-2600) PRIOR TO BEGINNING WORK.
- THE CONTRACTOR SHALL BE RESPONSIBLE FOR ALL CONSTRUCTION SIGNING, BARRICADES AND TRAFFIC DELINEATION TO CONFORM TO THE STATE OF NEVADA, DEPARTMENT OF TRANSPORTATION, "NEVADA WORK ZONE TRAFFIC CONTROL MANUAL," AND THE MANUAL FOR UNIFORM TRAFFIC CONTROL DEVICES.
- THE WORK IN THIS CONTRACT INCLUDES ALL ONSITE AND OFFSITE WORK SHOWN ON THESE DRAWINGS, DESCRIBED IN THE SPECIFICATIONS, OR REASONABLY IMPLIED.
- SHOULD ANY PREHISTORIC OR HISTORIC REMAINS/ARTIFACTS BE DISCOVERED DURING CONSTRUCTION, WORK SHALL TEMPORARILY BE HALTED AT THE SPECIFIC SITE AND THE CONTRACTOR SHALL NOTIFY THE DEPARTMENT OF CONSERVATION AND NATURAL RESOURCES, DIVISION OF HISTORIC PRESERVATION AND ARCHAEOLOGY FOR THEIR INVESTIGATION OF THE DISCOVERY. THE PERIOD OF TEMPORARY DELAY SHALL BE LIMITED TO A MAXIMUM OF TWO WORKING DAYS FROM THE DATE OF NOTIFICATION.
- ALL DIMENSIONS AND DISTANCES ARE TO FRONT FACE OF CURB, CURB RETURN, FACE OF BUILDING, FACE OF WALL, FLOW LINE, PROPERTY LINE, CENTER OF STRIPING, CENTER LINE OF PIPE OR MANHOLE, OR END OF IMPROVEMENTS.
- THE CONTRACTOR SHALL PROTECT FROM DAMAGE EXISTING IMPROVEMENTS ON AND AROUND THE SITE INCLUDING, BUT NOT LIMITED TO, PAVEMENT, CURB & GUTTER, SIDEWALK, LANDSCAPING, SIGNAGE, STORM & SANITARY SEWERS, UTILITIES, TELEPHONE, AND CABLE TELEVISION. THE CONTRACTOR SHALL ASSUME SOLE RESPONSIBILITY FOR THE REPAIR AND/OR REPLACEMENT OF ANY IMPROVEMENTS (NEW OR EXISTING) DAMAGED THROUGHOUT THE COURSE OF CONSTRUCTION, EITHER AS A DIRECT RESULT OF HIS ACTIVITIES OR HIS FAILURE TO ADEQUATELY PROTECT THE IMPROVEMENT.
- THE CONTRACTOR SHALL UPON COMPLETION OF THE PROJECT, PREPARE AND SUBMIT TO THE OWNER OR HIS REPRESENTATIVE, RECORD DRAWINGS INDICATING BY DIMENSION AND DESCRIPTION ANY FACILITY CONSTRUCTED CONTRARY TO THAT SHOWN ON THE DRAWINGS OR DESCRIBED IN THE SPECIFICATIONS.
- PRIOR TO THEIR INCORPORATION INTO THE WORK, THE CONTRACTOR SHALL SUBMIT FOR THE ENGINEER'S APPROVAL AND MATERIAL SPECIFICATIONS FOR ALL MATERIALS TO BE USED ON THE PROJECT TO INCLUDE, BUT NOT BE LIMITED TO, ASPHALTIC CONCRETE AND PORTLAND CEMENT CONCRETE MIX DESIGN, AGGREGATE BASE QUALIFICATIONS, PIPE BEDDING, SELECT BACKFILL, PRECAST CONCRETE, CAST IRON GRATES AND COVERS, PIPING, FENCING, AND SIGNS.
- THE CONTRACTOR SHALL AT ALL TIMES, PROVIDE AND MAINTAIN EMERGENCY ACCESS TO THE PROJECT SITE IN ACCORDANCE WITH THE REQUIREMENTS OF THE FIRE PROTECTION AGENCY HAVING JURISDICTION OVER THE PROJECT SITE.
- ALL QUANTITIES SHOWN ON THE DRAWINGS ARE APPROXIMATE AND USED ONLY FOR PERMIT AND BOND PURPOSES ONLY. THEY SHALL NOT BE USED IN ANY WAY FOR BIDDING OR CONSTRUCTION PURPOSES. IT SHALL BE THE CONTRACTOR'S RESPONSIBILITY TO MAKE HIS OWN QUANTITY ESTIMATES FOR BIDDING AND CONSTRUCTION PURPOSES.
- INSPECTION REQUIREMENTS SHALL BE IN ACCORDANCE WITH THE WASHOE COUNTY STANDARDS OR THE STANDARD SPECIFICATIONS, WHICHEVER IS THE MORE STRINGENT.
- THE CONTRACTOR SHALL SUBMIT A SCHEDULE OF EVENTS TO THE ENGINEER AND DEVELOPER AND UPDATE IT EVERY WEEK, OR SUSTAIN WORK UNTIL IT IS COMPLETED, WITH NO TIME DELAYS IN THE CONTRACT PERIOD. THE SCHEDULE IS FOR THE OWNER AND HIS COORDINATION OF THE OVERALL OPERATION OF THE CONSTRUCTION. THE CONTRACTOR SHALL IN NO WAY IMPED THE OVERALL PERFORMANCE OF THE OWNER'S OPERATIONS.
- THE CONTRACTOR SHALL SUBMIT TO THE ENGINEER PRIOR TO ITS INCORPORATION INTO THE WORK SHOP DRAWINGS, MATERIAL SPECIFICATIONS FOR ALL MATERIALS TO BE USED IN THE PROJECT TO INCLUDE, BUT NOT LIMITED TO, ASPHALTIC CONCRETE AND PORTLAND CEMENT MIX DESIGN, AGGREGATE BASE QUALIFICATIONS, PIPE BEDDING, SELECT BACKFILL, CAST CONCRETE, CAST IRON GRATES AND COVERS, PIPING, FENCING, BOXES AND COVERS, AND SIGNS.
- ALL UNDERGROUND PIPING AND CONDUITS SHALL HAVE THEIR IDENTIFICATIONS WRITING ON MATERIALS FACING UPWARD TO EASILY BE SEEN BY THE WASHOE COUNTY INSPECTOR.

- DEMOLITION NOTES:**
- THE CONTRACTOR MAY SALVAGE ITEMS NOT SPECIFICALLY DESIGNATED AS NON-SALVAGEABLE WITH WRITTEN PERMISSION FROM THE ENGINEER. THE NON-SALVAGEABLE MATERIALS SHALL BE DISPOSED OF AT THE APPROPRIATE LOCATIONS.
 - THE CONTRACTOR SHALL BE RESPONSIBLE FOR THE PROPER OFF-SITE DISPOSAL OF MATERIALS TO BE REMOVED AND DISPOSED OF. THE CONTRACTOR SHALL COORDINATE WITH THE ENGINEER, AREAS TO BE USED FOR THE TEMPORARY STOCKPILING OF MATERIALS TO BE REMOVED.
 - THE CONTRACTOR SHALL WET-DOWN AND TARP EVERY TRUCK LOADS LEAVING THE SITE FOR A DISPOSAL AREA. THIS PROCEDURE IS CRITICAL TO THE DUST ABATEMENT PLAN AND WILL BE STRICTLY ENFORCED.
 - THE CONTRACTOR SHALL APPLY AND PAY FOR ALL PERMITS REQUIRED FOR THIS PROJECT, UNLESS SPECIFIED OTHERWISE.
 - IF STRUCTURE REMOVAL CREATES SIGNIFICANT DEPRESSIONS, THE CONTRACTOR SHALL ROUND OFF THE SIDES TO 3:1 SLOPE, AND COMPACT TO 85% M.D.D.
 - ALL SAWCUT LINES SHALL BE NEATLY DONE, PARALLEL AND PERPENDICULAR TO EXISTING IMPROVEMENTS. SAWCUT LINES SHALL BE ADJUSTED TO REASONABLY INCORPORATE AREAS OF DAMAGED CURB, GUTTER, SIDEWALK, AND PAVEMENT.
 - REMOVE AND DISPOSE OF ANY DEBRIS THAT IS WITHIN THE CONSTRUCTION LIMITS AND IS NOT SPECIFICALLY CALLED OUT.

SITE NOTES:

- REFERENCE ARCHITECTURAL, ELECTRICAL, MECHANICAL, AND S.P.P.CO. UTILITY PLANS FOR FURTHER IMPROVEMENTS WITHIN THIS CONTRACT.
- REFERENCE LANDSCAPING PLANS FOR MOUNDING, PLANTING, AND IRRIGATION CONSTRUCTION.
- ALL INSPECTION AND TESTING WILL BE TO THE WASHOE COUNTY STANDARDS OR THE "ORANGE BOOK", WHICHEVER IS MORE STRINGENT.
- ALL P.C.C. CURB, GUTTER, SIDEWALK, AND SLOPE PAVING SHALL BE CLASS AA OR DA CONCRETE (4000 PSI), WITH BROOM FINISH, UNLESS OTHERWISE INDICATED.
- ALL CONCRETE CURB AND GUTTER SHALL HAVE 1/2" EXPANSION JOINTS EVERY 30 FOOT INTERVAL, AT ALL POINTS ABUTTING BUILDINGS OR STRUCTURES, AND AT ALL CURB RETURNS UNLESS OTHERWISE APPROVED IN WRITING BY THE ENGINEER. EXPANSION JOINTS ABUTTING BUILDINGS AND STRUCTURES SHALL HAVE SILICONE APPLIED TO THE JOINT TO PREVENT WATER INTRUSION. WEAKENED PLANE JOINTS SHALL BE EVERY 10 FEET AND STRUCK-THRU AS THE SPECIFICATIONS FOR PUBLIC WORKS CONSTRUCTION INDICATES.
- CONCRETE SIDEWALKS SHALL HAVE 1/2" EXPANSION JOINTS AT ALL POINTS ABUTTING BUILDINGS AND STRUCTURES, EVERY 30 FOOT INTERVAL, AT ALL SIDEWALK RETURNS, AND OPPOSITE EXPANSION JOINTS IN ADJACENT CURB. EXPANSION JOINTS ABUTTING BUILDINGS AND STRUCTURES SHALL HAVE SILICONE APPLIED TO THE JOINT TO PREVENT WATER INTRUSION. WEAKENED PLANE JOINTS SHALL BE LOCATED AT INTERVALS NOT EXCEEDING 1.2 TIMES THE WIDTH AND NO MORE FREQUENTLY THAN 0.8 TIMES THE WIDTH. IN NO CASE SHALL REGULAR INTERVALS OF WEAKENED PLANE JOINTS IN EITHER DIRECTION EXCEED 10 FEET.
- THE CONTRACTOR SHALL INSTALL PAVEMENT STRIPING AS ILLUSTRATED ON THE PLANS PER THE STANDARD SPECIFICATIONS. PARKING STALLS SHALL BE MARKED WITH A 4" SOLID "TRAFFIC WHITE" PAINTED LINES. FIRE LANES SHALL BE MARKED WITH SOLID "TRAFFIC RED" PAINTED CURBS (TOP AND FRONT FACE) OR 4" PAINTED LINES IF INDICATED. ALL SIGNAGE SHALL BE IN CONFORMANCE WITH THE MANUAL OF UNIFORM TRAFFIC CONTROL DEVICES.
- IN ALL AREAS WHERE NEW A.C. PAVEMENT OR PATCH IS TO MATCH EXISTING PAVEMENT, THE CONTRACTOR SHALL SAWCUT AND REMOVE THE EXISTING PAVEMENT 24" FROM SUCH IMPROVEMENTS OR AS INDICATED ON THE PLANS. NEW PAVEMENT OR PAVEMENT PATCH SHALL CONFORM TO THE EXISTING PAVEMENT AT THIS POINT AND TRANSITION SMOOTHLY TO THE NEW IMPROVEMENTS.
- IN AREAS WHERE NEW CURB, GUTTER OR SIDEWALK IS TO MATCH EXISTING, THE CONTRACTOR SHALL REMOVE THE EXISTING CURB, GUTTER OR SIDEWALK TO THE CLOSEST JOINT.
- THE CONTRACTOR SHALL CLOSELY COORDINATE CONSTRUCTION WITH OTHER TRADE CONTRACTORS, TO INSURE ADEQUATE ACCESS TO THE BUILDING SITE.
- THE CONTRACTOR SHALL MAINTAIN FIRE ACCESS TO ALL THE BUILDINGS TO THE SATISFACTION OF THE WASHOE COUNTY FIRE DEPARTMENT.
- ALL DIMENSIONS AND DISTANCES ARE TO FRONT FACE OF CURB, CURB RETURNS, FACE OF BUILDINGS, FACE OF WALL, FLOWLINE, PROPERTY LINE, CENTER OF STRIPING, CENTERLINE OF PIPE OR MANHOLES, CENTER OF FENCING, OR END OF IMPROVEMENTS.
- ALL QUANTITIES SHOWN ON THESE DRAWINGS ARE APPROXIMATE AND SHOULD BE USED FOR PERMIT PURPOSES ONLY. THEY SHALL NOT BE USED IN ANY WAY FOR BIDDING PURPOSES OR CONSTRUCTION PURPOSES. IT SHALL BE THE CONTRACTOR'S RESPONSIBILITY TO MAKE HIS OWN QUANTITY ESTIMATES FOR BIDDING AND CONSTRUCTION PURPOSES

WATER AND SANITARY SEWER CROSSING OR PARALLEL NOTES:

- WHEN THE SEWER MAIN CROSSES THE WATER MAIN, THE SEWER MAIN MUST BE LOCATED AT LEAST 18 INCHES LOWER THAN THE WATER MAIN.
- WHEN THE SEWER MAIN CROSSES A WATER SERVICE LATERAL, THE SEWER MAIN MUST BE LOCATED AT LEAST 18 INCHES LOWER THAN THE WATER SERVICE LATERAL.
- WHEN THE SEWER SERVICE LATERAL CROSSES A WATER MAIN OR WATER SERVICE LATERAL, THE SEWER SERVICE LATERAL MUST BE LOCATED AT LEAST 12 INCHES LOWER THAN THE WATER MAIN OR WATER SERVICE LATERAL.
- WHEN A SEWER OR STORM DRAIN MAIN PARALLELS A WATER MAIN OR WATER SERVICE LATERAL, THE SEWER MAIN MUST BE IN A SEPARATE TRENCH AND MUST HAVE A 10 FOOT HORIZONTAL SEPARATION.
- WHEN A SEWER SERVICE LATERAL PARALLELS A WATER MAIN OR WATER SERVICE LATERAL, THE SEWER SERVICE LATERAL MUST BE IN A SEPARATE TRENCH, BE LOCATED 12 INCHES LOWER, AND MUST HAVE A 48 INCH HORIZONTAL SEPARATION.

GRADING PLAN GENERAL NOTES:

- ALL WORK SHALL BE DONE IN ACCORDANCE WITH THE INTERNATIONAL BUILDING CODE, OSHA REQUIREMENTS FOR EXCAVATION, AND SPECIAL REQUIREMENTS OF THE PERMIT. VIOLATIONS SHALL RESULT IN THE STOPPAGE OF ALL WORK UNTIL THE VIOLATION IS CORRECTED.
- NO WORK SHALL BE STARTED WITHOUT FIRST NOTIFYING THE WASHOE COUNTY INSPECTOR AT LEAST ONE (1) WORKING DAY BEFORE WORK IS COMMENCED.
- SLOPES SHALL BE NO STEEPER THAN TWO (2) HORIZONTAL TO ONE (1) VERTICAL, OR AS DETERMINED BY THE SOILS ENGINEER AND APPROVED BY THE COUNTY.
- FILLS SHALL BE PLACED IN ACCORDANCE WITH THE REQUIREMENTS OF THE 'STANDARD SPECIFICATIONS FOR PUBLIC WORKS CONSTRUCTION' AND WASHOE COUNTY MUNICIPAL CODE (WHEN APPLICABLE).
- THE ENGINEER OF RECORD SHALL PROVIDE THE COUNTY WITH COPIES OF ALL TEST RESULTS ON A WEEKLY BASIS AND A BOUND REPORT OF THE TEST RESULTS AND INSPECTION REPORTS, ARRANGED IN CHRONOLOGICAL ORDER, AT THE COMPLETION OF THE PROJECT. THE ENGINEER OF RECORD SHALL PROVIDE THE COUNTY WITH AN OPINION REGARDING THE CONSTRUCTION SIMILAR TO THE FOLLOWING:
A) DIMENSION FROM DOWN-STREAM SSMH TO EACH LATERAL
B) CHANGES IN DIMENSION BETWEEN SSMH'S
C) CHANGES IN I.E.'S
- FILL AREAS SHALL BE CLEARED OF ALL VEGETATION AND DEBRIS, SCARIFIED, AND BE APPROVED BY THE ENGINEER OF RECORD PRIOR TO THE PLACING OF FILL.
- PROTECTIVE MEASURES AND TEMPORARY DRAINAGE PROVISIONS SHALL BE USED TO PROTECT ADJOINING PROPERTIES DURING CONSTRUCTION OF IMPROVEMENTS.
- DUST SHALL BE CONTROLLED BY THE CONTRACTOR TO THE SATISFACTION OF THE COUNTY AND IN ACCORDANCE WITH THE AIR QUALITY PERMIT FROM THE NEVADA DIVISION OF ENVIRONMENTAL PROTECTION WHEN REQUIRED.
- ALL STREETS SHALL BE MAINTAINED FREE OF DUST AND MUD CAUSED BY GRADING OPERATIONS. ALL OPERATIONS SHALL COMPLY WITH THE REQUIREMENTS OF THE STORMWATER DISCHARGE PERMIT FROM THE NEVADA DIVISION OF ENVIRONMENTAL PROTECTION.
- THE DEVELOPER'S ENGINEER OR SURVEYOR SHALL SET GRADE STAKES FOR ALL DRAINAGE DEVICES AND THE CONTRACTOR SHALL OBTAIN INSPECTION BEFORE PLACING CONCRETE.
- FINISHED GRADING SHALL BE COMPLETED AND APPROVED, AND SLOPE PLANTING AND IRRIGATION SYSTEMS INSTALLED BEFORE ISSUANCE OF A CERTIFICATE OF OCCUPANCY.
- NO ROCK OR SIMILAR MATERIAL GREATER THAN SIX INCHES (6") IN DIAMETER SHALL BE PLACED IN THE FILL UNLESS RECOMMENDATIONS FOR SUCH PLACEMENT HAVE BEEN SUBMITTED BY THE SOILS ENGINEER IN ADVANCE AND APPROVED BY THE COUNTY.
- THE SOILS ENGINEER SHALL APPROVE ALL GRADING INCLUDING COMPACTION REQUIREMENTS AND THE STABILITY OF SLOPES CREATED, EXISTING OR REMAINING.
- IN THE EVENT OF CHANGES ARISING DURING CONSTRUCTION, THE DEVELOPER SHALL BE RESPONSIBLE FOR DETERMINING AN ACCEPTABLE SOLUTION AND REVISITING THE PLANS FOR REVIEW AND APPROVAL BY WASHOE COUNTY ENGINEERING. NO CHANGES IN THE DESIGN SHALL BE PERMITTED UNLESS WRITTEN APPROVAL IS GIVEN BY THE COUNTY.
- EROSION CONTROL:
 - A STANDBY CREW FOR EMERGENCY WORK SHALL BE AVAILABLE AT ALL TIMES. NECESSARY MATERIALS SHALL BE AVAILABLE ON-SITE AND STOCKPILED AT APPROVED LOCATIONS TO FACILITATE RAPID CONSTRUCTION OF TEMPORARY DEVICES OR TO REPAIR DAMAGED EROSION CONTROL MEASURES.
 - AFTER A RAINSTORM, ALL SILT AND DEBRIS SHALL BE REMOVED FROM CHECK BERMS AND DESILTING FACILITIES. GRADED SLOPE SURFACE PROTECTION MEASURES DAMAGED DURING THE RAINSTORM SHALL ALSO BE REPAIRED.
 - FILL SLOPES AT THE PROJECT PERIMETER MUST DRAIN AWAY FROM THE TOP OF THE SLOPE AT THE CONCLUSION OF EACH WORKING DAY.
 - A SIX-FOOT (6') HIGH PERIMETER FENCE OR A TWENTY-FOUR (24) HOUR GUARD SHALL BE POSTED ON THE SITE WHENEVER THE DEPTH OF WATER IN A FACILITY EXCEEDS EIGHTEEN INCHES (18"). (ORD. 2001-23, DEVELOPMENT STANDARDS)

UTILITY NOTES:

- THE CONTRACTOR SHALL PERFORM A SEWER MANDRIL TEST IN THE PRESENCE OF THE ENGINEER AND OWNER.
- THE CONTRACTOR SHALL BALL AND FLUSH ALL SEWER AND STORM DRAIN LINES IN THE PRESENCE OF THE ENGINEER AND OWNER.
- THE CONTRACTOR SHALL PERFORM AN AIR PRESSURE TEST ON ALL SEWER LINES IN ACCORDANCE WITH THE STANDARD SPECIFICATIONS FOR PUBLIC WORK CONSTRUCTION, AND IN THE PRESENCE OF THE ENGINEER, OWNER AND WASHOE COUNTY.
- THE CONTRACTOR SHALL AT ALL TIMES, PROVIDE AND MAINTAIN EMERGENCY ACCESS TO THE PROJECT SITE IN ACCORDANCE WITH THE REQUIREMENTS OF THE FIRE PROTECTION AGENCY HAVING JURISDICTION OVER THE PROJECT SITE.
- ADD 4500 TO ALL FINISH GRADE OR INVERT ELEVATIONS.
- THE CONTRACTOR SHALL ADJUST ALL UTILITY BOXES, MANHOLE COVERS, DRAIN INLETS, VALVE COVERS, ETC. TO MATCH FINISH GRADE IN THE CONSTRUCTION AREA UNLESS OTHERWISE APPROVED BY THE ENGINEER.
- THE CONTRACTOR SHALL EXCAVATE FOR AND EXPOSE EXISTING UNDERGROUND UTILITIES WHERE CONNECTIONS ARE TO BE MADE PRIOR TO ANY CONSTRUCTION. SHOULD ANY ADJUSTMENTS IN LINE OR GRADE BE NECESSARY, THE CONTRACTOR SHALL BRING IT TO THE ATTENTION OF THE ENGINEER IMMEDIATELY.

- THE CONTRACTOR SHALL COORDINATE UNDERGROUND UTILITY CONSTRUCTION IN SUCH A MANNER AS TO PREVENT ANY CONFLICT WHERE UTILITY LINES CROSS.
- THE CONTRACTOR SHALL COORDINATE PRE-CONSTRUCTION MEETINGS WITH ALL GOVERNING AGENCIES AND UTILITY COMPANIES PRIOR TO THE COMMENCEMENT OF ANY CONSTRUCTION.
- ALL PVC SANITARY SEWER PIPE SHALL BE SDR 35 UNLESS OTHERWISE NOTED; ALL PVC STORM DRAIN PIPE SHALL BE SERIES 46 UNLESS OTHERWISE NOTED; ALL RCP SHALL BE CLASS III UNLESS OTHERWISE NOTED.
- ALL CATCH BASIN OUTLETS SHALL BE FITTED WITH A "SUR-TRAP" AS PER THE DETAILS INDICATE. ALL CATCH BASINS SHALL HAVE A MINIMUM OF 12" DEEP SILT TRAP IN THE BOTTOM. ALL SURE TRAP SHALL BE MAINTAINED IN GOOD WORKING CONDITION AND NOT REMOVED.
- GAS AS SHOWN IS SCHEMATIC ONLY. FINAL DESIGN SHALL BE PERFORMED BY S.P.P.CO. CONSTRUCTION SHALL FOLLOW THOSE PLANS AND SPECIFICATIONS.
- THE CONTRACTOR SHALL INSTALL A BLUE REFLECTOR IN THE STREET CENTERLINE ADJACENT TO ALL FIRE HYDRANTS AND PAINT THE CURB "RED" PER THE REQUIREMENTS OF THE FIRE DEPARTMENT.
- IT SHALL BE THE CONTRACTOR'S RESPONSIBILITY TO DETERMINE AND SUPPLY ALL MECHANICAL JOINTS REQUIRED TO OBTAIN SUFFICIENT DEPTHS AT ALL SEWER, STORM DRAIN, AND ELECTRICAL CROSSINGS. HE SHALL ALSO BE RESPONSIBLE TO DETERMINE AND SUPPLY ALL MECHANICAL JOINTS DUE TO GRADE CHANGES AT ALL SLOPES.
- PIPE BEDDING SHALL CONFORM TO REQUIREMENTS FOR CLASS "A" BACKFILL IN SECTION 200.03.02 OF THE STANDARD SPECIFICATIONS FOR PUBLIC WORKS CONSTRUCTION. BEDDING MATERIAL WHICH MEETS THE REQUIREMENTS FOR CLASS "C" BACKFILL IN SUBSECTION 200.03.04 OF THE STANDARD SPECIFICATIONS, BETTER KNOWN AS THE 3/4" PIPE BEDDING MATERIAL AS APPROVED BY WASHOE COUNTY MAY BE USED WITH THE CONSENT OF THE ENGINEER. IF CLASS "C" BACKFILL IS ALLOWED, A VIBRATING PLATE COMPACTOR OF SUFFICIENT SIZE SHALL BE REQUIRED TO MAKE A MINIMUM OF (4) FOUR PASSES OVER THE MATERIAL AT 12" LIFTS, OR UNTIL SETTLEMENT CEASES.
- ELECTRICAL, TELEPHONE, AND CABLE TV DESIGN SHALL BE PROVIDED BY THE RESPECTIVE UTILITY COMPANIES. CONSTRUCTION SHALL FOLLOW THEIR PLANS AND SPECIFICATIONS.

GENERAL WATER NOTES:

- ALL CONSTRUCTION SHALL CONFORM TO WASHOE COUNTY STANDARDS.
- THE WATER SYSTEM SHALL CONFORM TO THE LATEST EDITION OF THE STANDARD SPECIFICATIONS FOR THE PUBLIC WORKS CONSTRUCTION. THE STANDARD DETAILS FOR PUBLIC WORKS ADOPTED BY WASHOE COUNTY (EXCEPT AS MODIFIED BY THESE PLANS OR SPECIAL PROVISIONS) AND WASHOE COUNTY UTILITY DIVISION STANDARDS.
- ALL PIPE PLUGS ARE TO BE EXTENDED 20' BEYOND END OF PAVEMENT OR 40' BEYOND VALVE, (WHICHEVER IS GREATER) WITH FLUSH VALVES AND AIR RELEASE ASSEMBLY, IF AT FINISH POINT.
- VALVES SHALL BE SPACED AT 500' MAXIMUM.
- ALL WATER SERVICE LATERALS SHALL HAVE A METER BOX INSTALLED.
- THE CONTRACTOR SHALL INSTALL A WATER METER BOX AND METER.
- WATER PIPE SHALL BE CLASS 150 PER AWWA C-900, UNLESS OTHERWISE SHOWN ON PLANS.
- SUBMITTALS FOR ALL WATER PIPE AND APPURTENANCES SHALL BE SUBMITTED AND APPROVED BY SUBMITTED AND APPROVED BY TMWA PRIOR TO CONSTRUCTION
- WATER PIPE FITTINGS SHALL BE D.I. OR C.I. IN ACCORDANCE WITH AWWA C-111 AND C-110 OR C-153.
- THE CONTRACTOR SHALL MEET WITH THE UTILITY SERVICES DIVISION PRIOR TO STARTING CONSTRUCTION ON THE WATER SYSTEM.
- WATER LINES SHALL BE CHLORINATED AND FLUSHED IN ACCORDANCE WITH AWWA STANDARDS AND TO THE SATISFACTION OF THE UTILITY DIVISION INSPECTOR PRIOR TO EXISTING WATER SYSTEM TIE IS MADE.
- NEW WATER LINES MUST PASS THE BACTERIOLOGICAL TEST AND THE PRESSURE TEST TO THE SATISFACTION OF THE UTILITY DIVISION INSPECTOR.
- THE UTILITY DIVISION INSPECTOR MUST APPROVE TIES TO EXISTING WATER LINES.
- THE CONTRACTOR SHALL NOTIFY THE UTILITY SERVICES DIVISION 48 HOURS PRIOR TO STARTING CONSTRUCTION ON THE WATER OR SEWER SYSTEM.
- VALVES INSTALLED UNDERGROUND SHALL BE EQUIPPED WITH A VALVE BOX, COVER AND CONDUCTOR PIPE. THE COVER SHALL BE MARKED "WATER".
- VALVES SHALL BE RESILIENT-SEATED GATE VALVES. IRON BODY, BRONZE-MOUNTED, AND NON-RISING MEETING THE REQUIREMENTS OF AWWA C-509. VALVES SHALL BE INSTALLED WITH THE STEMS IN A VERTICAL POSITION. VALVES SHALL OPEN "COUNTER-CLOCKWISE" AND SHALL HAVE 2" SQUARE OPERATING NUTS. VALVES SHALL BE INSTALLED IN ACCORDANCE WITH AWWA C-600 AND THE STANDARD SPECIFICATIONS.
- UNDERGROUND DETECTABLE WARNING TAPE SHALL BE AT LEAST 3" WIDE AND SHALL BE BLUE IN COLOR AND SHALL BE MARKED "CAUTION WATER LINE BURIED BELOW" AT LEAST EVERY 36".
- ALL METALLIC PARTS INSTALLED UNDERGROUND THAT DO NOT HAVE A FACTORY APPLIED PROTECTIVE COATING SHALL BE PROTECTED WITH A FIELD APPLIED BITUMINOUS COATING SUCH AS TAPE COAT, MASTIC OR EQUAL.
- REPRODUCIBLE AS-BUILT DRAWINGS SHALL BE SUPPLIED TO THE UTILITY SERVICES DIVISION PRIOR TO ACCEPTANCE OF PROJECT WITH THE FOLLOWING IDENTIFIED:

GENERAL:

 - CHANGE IN SLOPE OR ALIGNMENT
 - CHANGE IN SIZE OR TYPE OF SEWER AND WATER PIPE

SEWER:

 - DIMENSION FROM DOWN-STREAM SSMH TO EACH LATERAL
 - CHANGES IN DIMENSION BETWEEN SSMH'S
 - CHANGES IN I.E.'S

WATER:

 - CHANGES IN DIMENSIONS BETWEEN FITTINGS AND VALVES
 - CHANGES IN DIMENSIONS BETWEEN VALVES
 - CHANGES IN TYPES OF FITTINGS AND VALVES

- RECLAIMED WATER TREATED EFFLUENT GENERAL NOTES:**
- ALL COVERS FOR METER BOXES, VALVE BOXES, FLUSH VALVES, PRESSURE REDUCING VAULTS, AIR/VAC RELEASE ASSEMBLIES, AND ALL OTHER APPURTENANCES REQUIRING VAULTS OR BOXES SHALL BE PURPLE IN COLOR (PANTONE COLOR #512), LABELED "RECLAIMED WATER" OR "EFFLUENT", AND HAVE SECURED OR LOCKING LIDS. PURPLE COLORATION SHALL BE OBTAINED FROM THE MANUFACTURER OR BE APPLIED BY POWDER COATING OR EPOXY PAINT. ALL APPURTENANCES SHALL HAVE A PURPLE TAG ATTACHED WITH THE WORDING "WARNING RECYCLED/RECLAIMED WATER DO NOT DRINK" AND "AVISO AGUA IMPURA NO TOMAR" (T. CHRISTY ENTERPRISES; MAXI VALVE IDENTIFICATION TAG WITH DUCT TAPE AT 6 FEET MAXIMUM INTERVALS. TRACER WIRE SHALL BE LONG ENOUGH TO EXTEND FOUR (4) FEET ABOVE GROUND AND SHALL TERMINATE IN TEST STATION BOX "TRAX" R. TRACER WIRE SHALL BE ATTACHED TO SERVICE LATERALS WITH DUCT TAPE AT 3 FEET MAXIMUM INTERVALS, AND SHALL BE LONG ENOUGH TO EXTEND FOUR (4) FEET ABOVE GROUND AND SHALL TERMINATE IN METER BOX. TRACER WIRE SHALL BE PROVIDED FOR ALL IRRIGATION RECLAIMED WATER PIPING 3-INCH DIAMETER AND LARGER, BOTH WITHIN PUBLIC RIGHT-OF-WAY AND PRIVATE PROPERTY, AND SHALL BE PLACED ON TOP OF PIPE AND ATTACHED WITH DUCT TAPE AT 6 FEET MAXIMUM INTERVALS. TRACER WIRE SHALL BE LONG ENOUGH TO EXTEND FOUR (4) FEET ABOVE GROUND AND SHALL TERMINATE IN APPROPRIATE IRRIGATION CONTROL/VALVE BOX AT MAXIMUM 500 FEET INTERVALS. WIRE SHALL BE #12 AWG, INSULATED, STRANDED COPPER, THHN 600V. PRIOR TO ACCEPTANCE OF THE RECLAIMED WATER LINES(S) BY THE CITY OF SPARKS, THE CONTRACTOR SHALL PERFORM A CONTINUITY TEST AFTER BACKFILLING THE TRENCH TO THE SATISFACTION OF THE CITY OF SPARKS INSPECTOR AND/OR ENGINEER.
 - ALL BURIED IRRIGATION PIPINGS UPSTREAM OF AN ELECTRICAL CONTROL VALVE SHALL BE PURPLE PLASTIC PIPE OR BE ENCASED IN PURPLE POLYETHYLENE OR BAGS LABELED "CAUTION: BURIED RECLAIMED WATER LINE BELOW" AT INTERVALS NO GREATER THAN 5 FEET. FOR POLYETHYLENE (PE) SERVICE PIPE, PURPLE STRIPES ARE ACCEPTABLE.
 - ALL PIPING DOWNSTREAM OF AN ELECTRIC CONTROL VALVE SHALL BE PURPLE PLASTIC OR HAVE PURPLE RECLAIMED WARNING TAPE PLACED ON TOP OF THE PIPE. THIS DOES NOT APPLY TO FLEXIBLE POLYETHYLENE TUBING USED IN DRIP ZONES.
 - BURIED WARNING AND IDENTIFICATION TAPE SHALL BE POLYETHYLENE PLASTIC, METALLIC COLOR DETECTABLE WARNING TAPE. AWWA, APWA, AND AWWA RESISTANT. PERMANENT MARKING, UNAFFECTED BY MOISTURE OR SOIL. MINIMUM FIVE (5) MILS THICK BY 3-INCHES WIDE. WARNING TAPE SHALL BE MANUFACTURED SPECIFICALLY FOR LOCATING, WARNING, AND IDENTIFICATION OF BURIED UTILITY LINES. APWA COLOR CODED PURPLE FOR RECLAIMED WATER WITH WARNING AND IDENTIFICATION IMPRINTED IN BOLD BLACK LETTERS CONTINUOUSLY OVER THE ENTIRE TAPE LENGTH. WARNING AND IDENTIFICATION TO READ "CAUTION: BURIED RECLAIMED WATER LINE BELOW" OR SIMILAR.
 - SIGNAGE SHALL BE POSTED AT ALL POINTS OF PUBLIC ACCESS (GATES, DRIVEWAYS, ETC.) AND AT MINIMUM 300 FEET INTERVALS ALONG PROJECT CENTERLINE OR BORDER, IF RECLAIMED WATER IS STORED IN PONDS. PROVIDE SIGNAGE AT PONDS. SIGNS SHALL BE BILINGUAL IN ENGLISH AND SPANISH. MINIMUM SIGN SIZE SHALL BE 9" x 12". REFERENCE CITY OF SPARKS RECLAIMED WATER TREATED EFFLUENT DETAIL SR-2.
 - RECLAIMED WATER LINES SHALL BE TREATED AS SEWER LINES AND ALL APPLICABLE SEPARATION FROM POTABLE WATER LINES SHALL BE MAINTAINED, UNLESS OTHERWISE AUTHORIZED.
 - HOSE BIBS SHALL NOT BE INSTALLED ON RECLAIMED WATER SYSTEMS.
 - CITY OF SPARKS INSPECTOR SHALL BE NOTIFIED BEFORE ANY SECTION OF PIPELINE IS BURIED TO ALLOW FOR INSPECTION AND POSITIONAL SPARKS OF THE FACILITIES.

| | | | |
|-------|----------------------------|-------|--------------------------------|
| AC | ACRES | LT | LEFT |
| AC | ASPHALTIC CONCRETE | MO | MIDDLE ORDNATE |
| ACP | ASBESTOS CONCRETE PIPE | MGD | MILLION GALLONS PER DAY |
| BC | BUILDING CORNER | MH | MANHOLE |
| BDY | BOUNDARY | MOVC | MID-ORDINATE VERTICAL CURVE |
| BVC | BEGIN VERTICAL CURVE | MW | MONITORING WELL |
| BSW | BACK OF SIDEWALK | NC | NOT IN CONTRACT |
| BW | BOTTOM OF WALL | NTS | NOT TO SCALE |
| C | RUNOFF COEFFICIENT | OG | ORIGINAL GROUND |
| CC | CORNER CONCRETE | OH | OVERHEAD |
| C&G | CURB AND GUTTER | OS | OFFSET LINE |
| CB | CATCH BASIN | P | PAD ELEVATION |
| CFS | CUBIC FEET PER SECOND | PC | POINT OF CURVATURE |
| C/L | CENTERLINE | PI | POINT OF INTERSECTION |
| CH | CHORD | PIP | PLASTIC IRRIGATION PIPE |
| CI | CAST IRON | PIV | POST INDICATOR VALVE |
| CMP | CORRUGATED METAL PIPE | PL | PROPERTY LINE |
| CO | CLEANOUT | PT | POINT OF TANGENCY |
| CONC. | CONCRETE | PRC | POINT OF REVERSE CURVATURE |
| CONST | CONSTRUCT | PVC | POLYVINYL CHLORIDE PIPE |
| CP | CONCRETE PIPE | Q | RADIUS |
| CPLG | COUPLING | R | RADIUS |
| CR | CURB RETURN | (R) | RADIAL |
| D | DELTA | REBAR | REINFORCING BARS |
| DCV | DETECTOR CHECK VALVE | RCB | REINFORCED CONCRETE BOX |
| DI | DROP INLET OR DUCTILE IRON | RCP | REINFORCED CONCRETE PIPE |
| DIA | DIAMETER | RE | RECLAIMED WATER |
| DET | DETAIL | REF | REFERENCE |
| E | ELECTRICAL | RET | RETURN |
| (EX) | EXISTING | RIB | RAPID INFILTRATION BASIN |
| EL | ELEVATION OR ELBOW | RIM | RIM ELEVATION |
| EC | END CURVE | ROW | RIGHT OF WAY |
| EP | EDGE OF PAVEMENT | RT | RIGHT |
| ES | EDGE OF SAWCUT LINE | S | SLOPE |
| EVC | END VERTICAL CURVE | SD | STORM DRAIN |
| FES | FLARED END SECTION | SF | SQUARE FOOT |
| FF | FINISH FLOOR | SHT | SHEET |
| FFC | FRONT FACE OF CURB | SS | SANITARY SEWER |
| FFW | FRONT FACE OF WALL | STA | STATION |
| FG | FINISH GRADE | S/W | SIDEWALK |
| FH | FIRE HYDRANT | T | TRANSFORMER |
| FLG | FLANGE | (T) | TELEPHONE |
| FL | FLOW LINE | TEE | PIPE CONNECTION |
| G | GAS | TB | TOP OF BANK |
| (G) | GROUND | TBC | TOP BACK OF CURB |
| GB | GRADE BREAK | TC | TOP OF CURB |
| GM | GAS METER | TC | TIME OF CONCENTRATION |
| GP | GALLONS PER MINUTE | TG | TOP OF GRADE |
| GV | GAS VALVE | TOE | TOE OF SLOPE |
| HOR | HORIZONTAL | TP | TOP OF PAVEMENT |
| HP | HIGH POINT | TV | TELEVISION |
| HS | HOUSE SERVICE | TW | TOP OF WALL |
| I | INTENSITY | TYP | TYPICAL |
| IE | INVERT ELEVATION | VC | VERTICAL CURVE |
| IPS | IRON PIPE SIZE | VERT | VERTICAL |
| IRR | IRRIGATION | VP | VERTICAL POINT OF INTERSECTION |
| L | LENGTH | W | WATER |
| LF | LINEAL FEET | WM | WATER METER |
| LOG | LIP OF GUTTER | WW | WATER VALVE |
| LP | LOW POINT | | |

ABBREVIATIONS

| | | | |
|--|--|--|---|
| | PROPOSED TYPE 1 CURB AND GUTTER | | STREET SIGN |
| | EXISTING TYPE 1 CURB AND GUTTER | | PIPE BOLLARD |
| | PROPOSED MEDIAN CURB | | BARBED WIRE FENCE |
| | EXISTING MEDIAN CURB | | CHAIN LINK FENCE |
| | EXISTING MAJOR CONTOUR | | ASPHALT CONCRETE PAVEMENT |
| | PROPOSED MAJOR CONTOUR | | CONCRETE |
| | EXISTING MINOR CONTOUR | | AIR RELEASE VALVE ASSEMBLY |
| | PROPOSED MINOR CONTOUR | | PROPOSED DRAINAGE SWALE |
| | GRADE BREAK | | EXISTING DRAINAGE SWALE |
| | EXISTING | | RECLAIMED WATER MAIN (DASHED IF EXISTING) |
| | SLOPE IN PERCENT | | FIRE WATER MAIN (DASHED IF EXISTING) |
| | ELEVATION @ FINISH GRADE | | WATER MAIN (DASHED IF EXISTING) |
| | ELEVATION @ TOP OF CURB | | SANITARY SEWER LATERAL |
| | ELEVATION @ GRADE BREAK | | GAS MAIN (DASHED IF EXISTING) |
| | ELEVATION @ FLOW LINE | | SPCC ELEC CONDUIT |
| | CATCH POINT | | THRUST BLOCK |
| | STORM DRAIN MANHOLE (DASHED IF EXISTING) | | CLEANOUT (DASHED IF EXISTING) |
| | CATCH BASIN | | FIRE HYDRANT |
| | PROPERTY LINE | | WATER VALVE |
| | LIGHT STANDARD | | STORM DRAIN MAIN (DASHED IF EXISTING) |
| | HEADWALL | | SANITARY SEWER MAIN (DASHED IF EXISTING) |
| | FLARED END SECTION | | SINGLE WATER SERVICE (METER & BACKFLOW PREVENTER) |
| | UTILITY POLE | | SANITARY SEWER MANHOLE (DASHED IF EXIST |

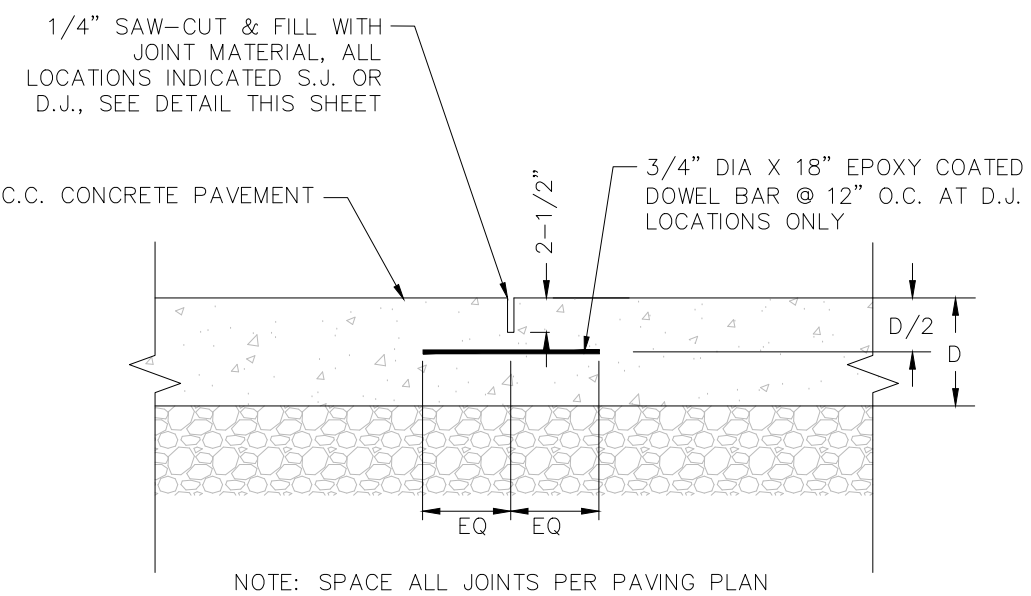

TRANSVERSE / LONGITUDINAL WEAKENED PLANE JOINT

SCALE: N.T.S.

1A

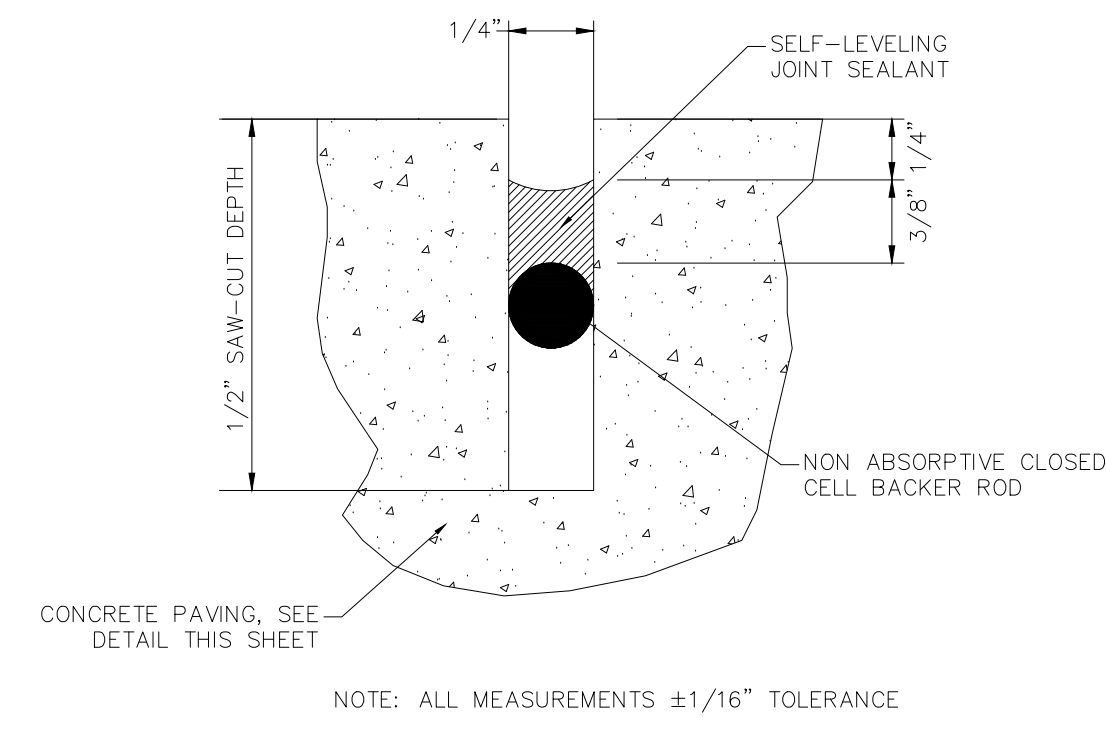

WEAKENED PLANE JOINT SINGLE SAWCUT

SCALE: N.T.S.

1

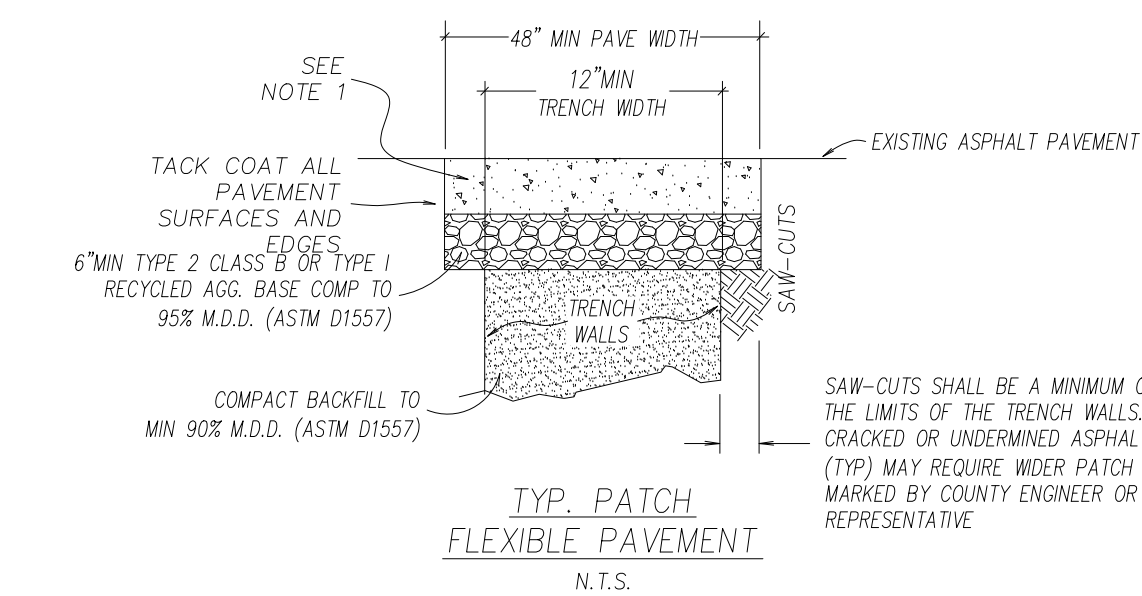
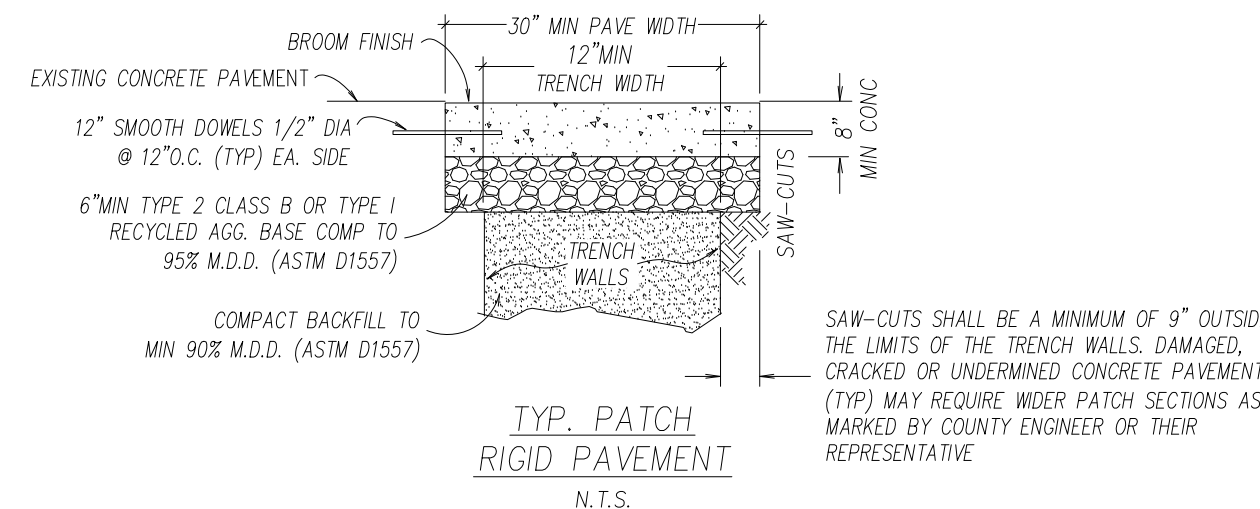

SEE PAGE 2 OF 2 FOR NOTES

| NO. | REVISED | DATE | STANDARD DETAILS FOR PUBLIC WORKS CONSTRUCTION | SECTION: |
|-----|-----------|---------|--|----------|
| 1 | Notes | 12/05SW | | WASHOE |
| 2 | Conc Note | 12/11SW | | |
| 3 | Notes | 1/15 ME | | |
| 4 | Notes | 2/17 BD | | |

PERMANENT PAVEMENT PATCH PAGE 1 OF 2

DRAWING NO: W-2.2

DATE: 4/94 vp

PAGE: 9

2

PAVEMENT PATCH DETAIL

SCALE: N.T.S.

- NOTES
- TRUCKEE MEADOWS PERMANENT PATCH TO MATCH THE DEPTH OF THE CONTIGUOUS PAVEMENT, BUT NO LESS THAN 4 INCHES AND NO MORE THAN 8 INCHES.
 - INCLINE VILLAGE PERMANENT PATCH TO MATCH THE DEPTH OF THE CONTIGUOUS PAVEMENT, BUT NO LESS THAN 6 INCHES AND NO MORE THAN 8 INCHES.
 - A STREET CUT PERMIT MUST BE OBTAINED FROM WASHOE COUNTY COMMUNITY SERVICES DEPARTMENT PRIOR TO CUTTING ANY PUBLIC RIGHT-OF-WAY.
 - ALL CONCRETE AND ASPHALT REMOVAL AND REPLACEMENT SHALL BE TO SAW-CUT LINES AND SHALL BE DONE BY EXCAVATION CONTRACTOR OR SUBCONTRACTOR. ALL SAW-CUTS SHALL BE VERTICAL AND IN STRAIGHT LINES PARALLEL OR PERPENDICULAR TO THE TRENCH OR TO THE SATISFACTION OF THE COUNTY ENGINEER.
 - RIGID PAVEMENT: IF SAW-CUT IS WITHIN 36" OF EDGE OR JOINT ON PCC PAVE, REMOVE PCC TO EXISTING EDGE AND REPLACE ENTIRE SECTION. FLEXIBLE PAVEMENT: IF SAW-CUT IS WITHIN 36" OF EDGE OF PAVEMENT, EDGE OF VALLEY GUTTER, LIP OF CURB AND GUTTER, OR A PREVIOUS PATCH, REMOVE EXISTING PAVEMENT TO THAT EDGE AND REPLACE THE ENTIRE SECTION.
 - CONCRETE SHALL BE A MINIMUM OF 6.25 SACKS OF TYPE II CEMENT (588 POUNDS PER CUBIC YARD OF CONCRETE) 4000PSI WITH FIBERMESH AND 4.5% TO 7.5% AIR.
 - HOT MIX ASPHALT SHALL BE TYPE 3, PG64-28 (OR COUNTY APPROVED EQUIVALENT), 3% VOIDS, 50 BLOWS PER SIDE MIX WITH LIME AND NO MORE THAN 15% RECYCLED ASPHALT PAVEMENT COMPACTED TO A MINIMUM OF 93% RICE RELATIVE COMPACTION.
 - ALL CONSTRUCTION SHALL BE IN ACCORDANCE WITH THE LATEST EDITION OF THE STANDARD SPECIFICATIONS FOR PUBLIC WORKS CONSTRUCTION.
 - DEPTH OF BASE TO BE 6" MINIMUM OR MATCH EXISTING BASE IF GREATER, INCLUDING UNPAVED STREETS.
 - USE OF ROCK WHEEL TRENCHING MACHINES OR SIMILAR EQUIPMENT SHALL NOT BE PERMITTED WITHIN PAVED AREAS OR WITHIN 1 FOOT OF EDGE OF PAVING.
 - CONCRETE SLURRY WITH MINIMUM OF 1 SACK OF CEMENT PER CUBIC YARD OF SLURRY OR OTHER APPROVED MIX DESIGN MAY BE USED FOR BASE COURSE, BEDDING OR BACKFILL IF APPROVED BY THE COUNTY ENGINEER AND UTILITY COMPANIES.
 - PERMANENT RESURFACING SHALL NOT BE PLACED ON TRENCHES BACKFILLED WITH CONCRETE SLURRY FOR A MINIMUM OF 7 DAYS AFTER PLACEMENT OF THE CONCRETE SLURRY OR SIMILAR MATERIAL.
 - ALL TEMPORARY PATCHES SHALL BE HOT-MIX ASPHALT A MINIMUM OF 3 INCHES THICK AND MUST BE INSTALLED WITHIN 24 HOURS AFTER THE TRENCH IS BACKFILLED, OR COVERED WITH STEEL PLATES AND BARRICADED TO THE SATISFACTION OF THE COUNTY ENGINEER.
 - A NEGOTIATED RECONSTRUCTION, INCLUDING BUT NOT LIMITED TO GRIND AND OVERLAY, SHALL BE DETERMINED BY THE COUNTY ENGINEER DEPENDENT UPON THE EXTENT OF THE TRANSVERSE AND LONGITUDINAL EXCAVATIONS.
 - ALL PERMANENT PAVEMENT PATCHES REQUIRE ASPHALT SEAL COATS. THE TYPE SHALL BE DETERMINED BY THE COUNTY ENGINEER.

| NO. | REVISED | DATE | STANDARD DETAILS FOR PUBLIC WORKS CONSTRUCTION | SECTION: |
|-----|-----------|---------|--|----------|
| 1 | Notes | 12/05SW | | WASHOE |
| 2 | Conc Note | 12/11SW | | |
| 3 | Notes | 1/15 ME | | |
| 4 | Notes | 2/17 BD | | |

PERMANENT PAVEMENT PATCH PAGE 2 OF 2

DRAWING NO: W-2.2

DATE: 4/94 vp

PAGE: 9

3

PAVEMENT PATCH DETAIL

SCALE: N.T.S.

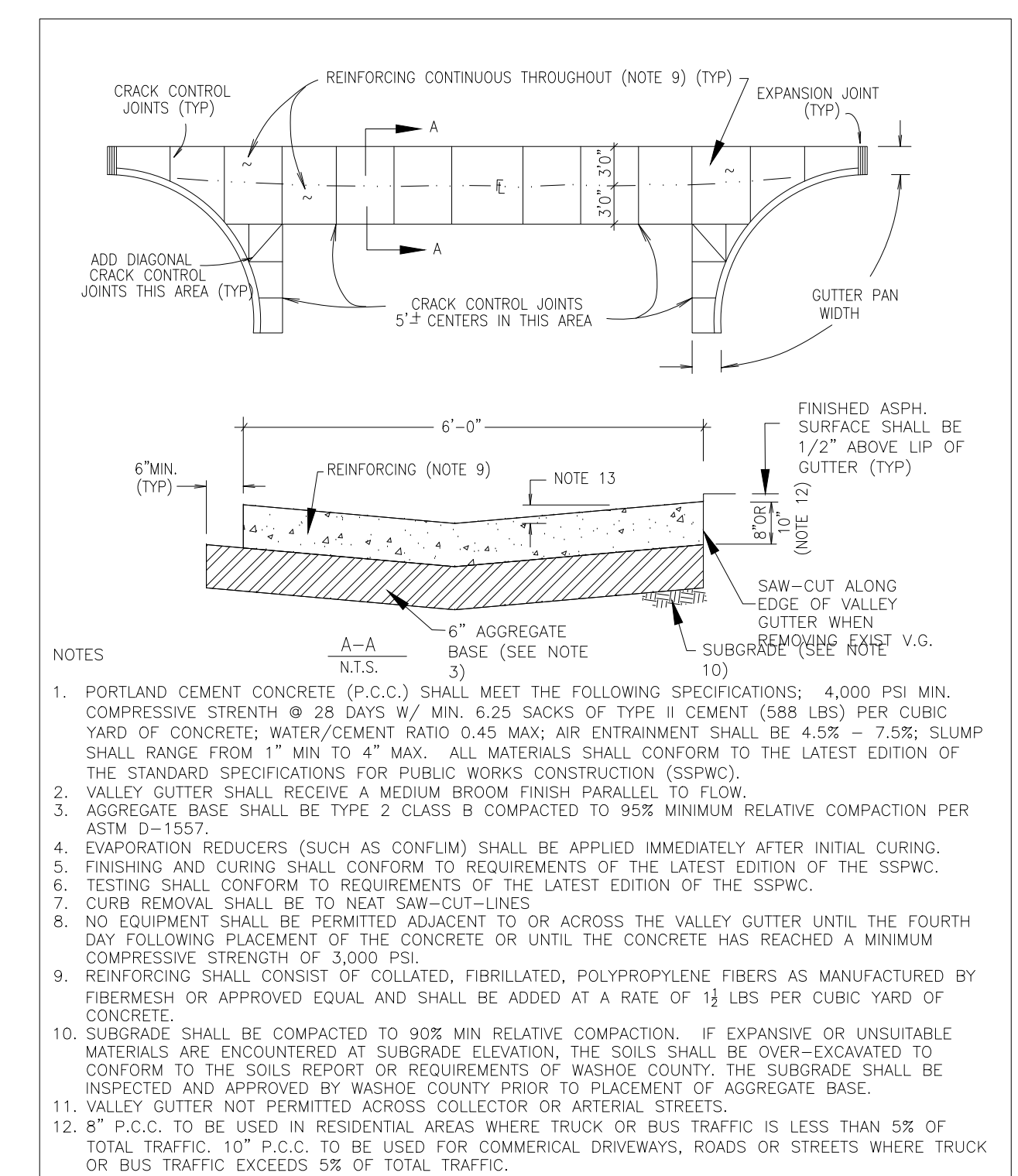

| NO. | REVISED | DATE | STANDARD DETAILS FOR PUBLIC WORKS CONSTRUCTION | SECTION: |
|-----|------------|----------|--|----------|
| 1 | REDRAW | 11/02 vp | | WASHOE |
| 2 | MISC NOTES | 2/94 vp | | |
| 3 | Notes | 12/11sw | | |
| 4 | Revisions | 09/16sw | | |

P.C.C. VALLEY GUTTER

DRAWING NO: W-11

DATE: 09/16sw

PAGE: 24

4

P.C.C. VALLEY GUTTER

SCALE: N.T.S.

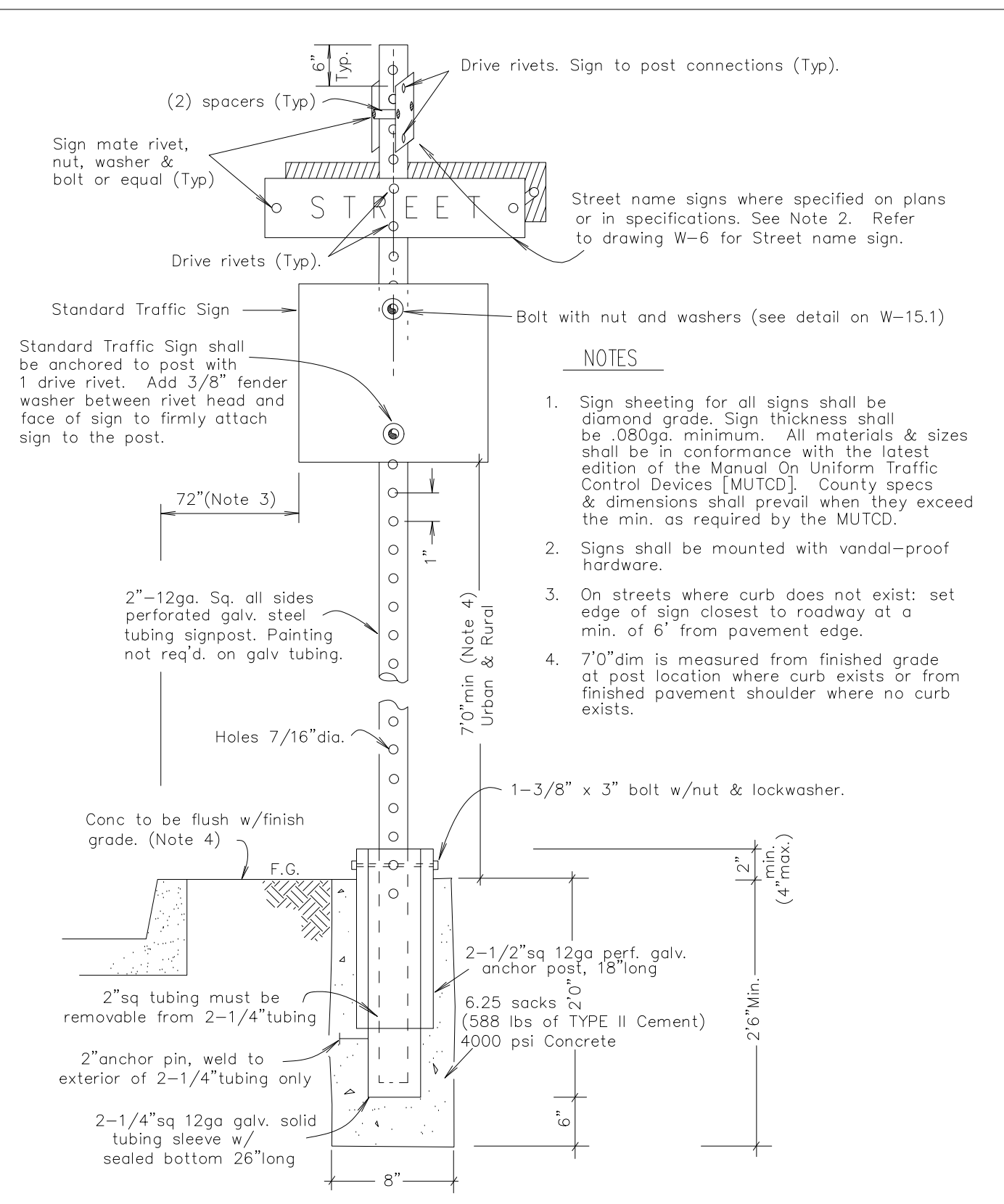

| NO. | REVISION | DATE | STANDARD DETAILS FOR PUBLIC WORKS CONSTRUCTION | SECTION: |
|-----|----------|---------|--|----------|
| 1 | Concrete | 12/11sw | | WASHOE |

STANDARD TRAFFIC SIGN

DRAWING NO: W-15.1

DATE: 7/11

PAGE: 28

5

TRAFFIC SIGN DETAIL

SCALE: N.T.S.

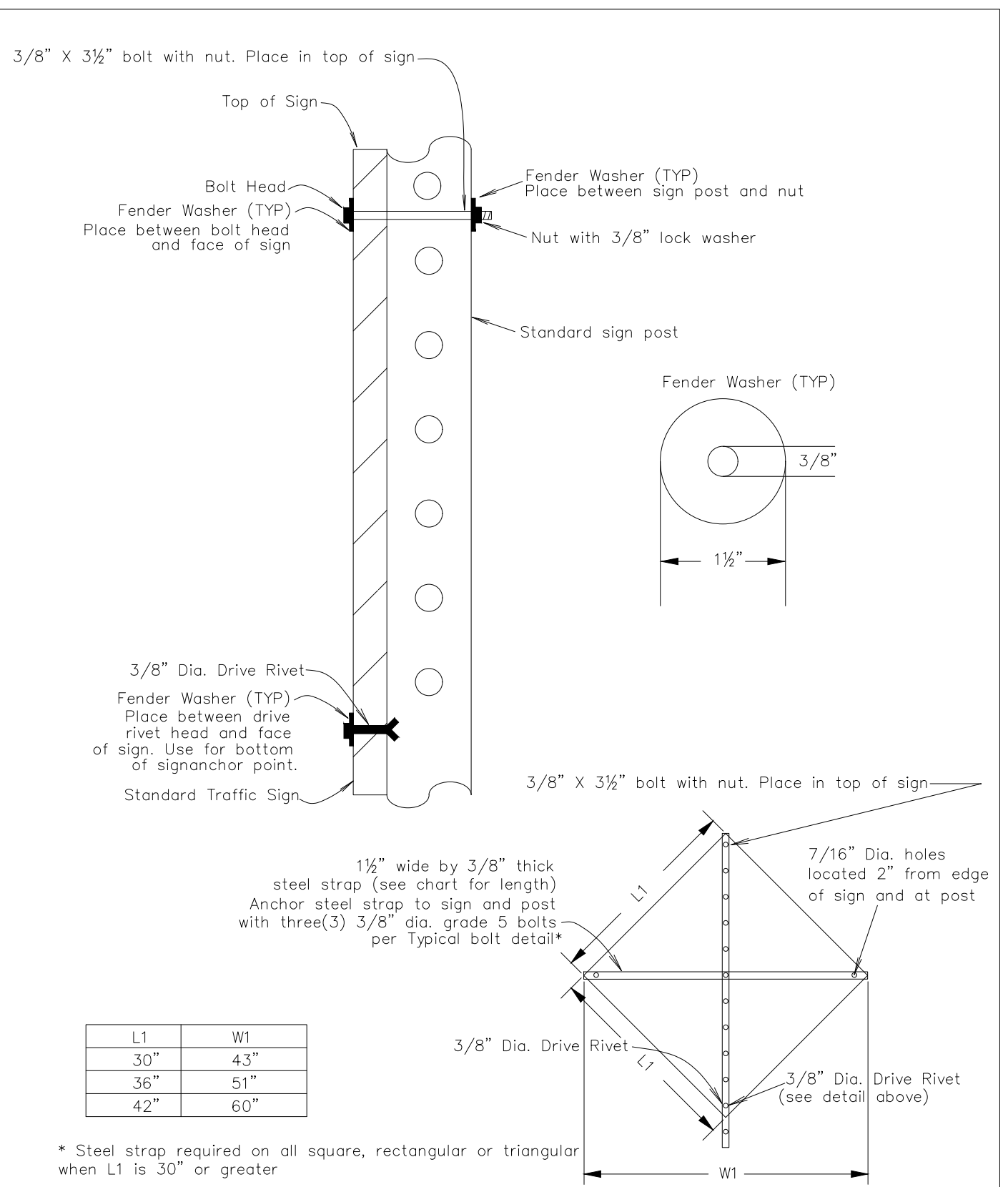

| NO. | REVISION | DATE | STANDARD DETAILS FOR PUBLIC WORKS CONSTRUCTION | SECTION: |
|-----|----------|------|--|----------|
| 1 | | | | WASHOE |
| 4 | | | | |
| 5 | | | | |
| 6 | | | | |

STANDARD TRAFFIC SIGN

DRAWING NO: W-15.1

DATE: 07/11SW

PAGE: 28

6

TRAFFIC SIGN DETAIL

SCALE: N.T.S.

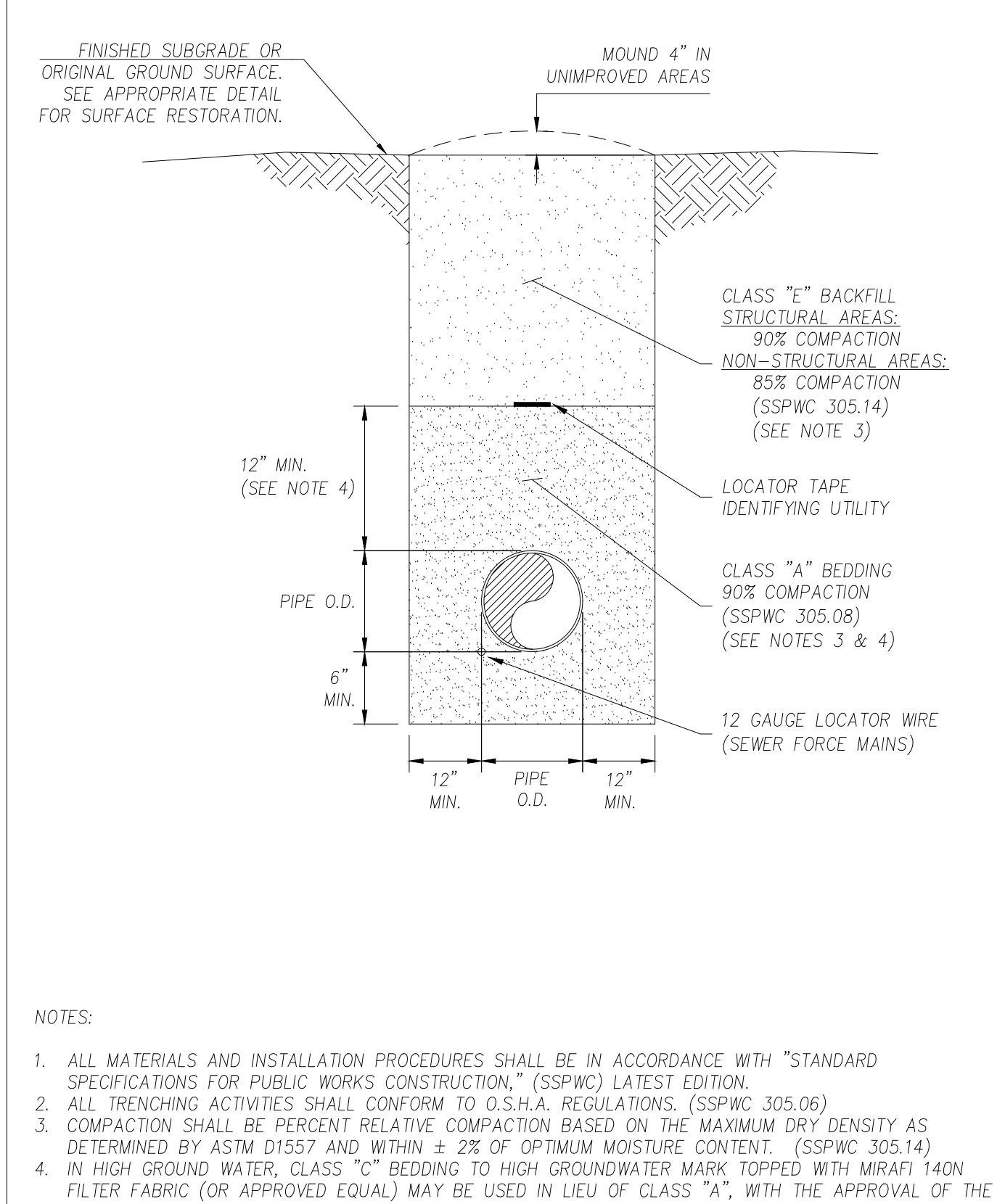

| NO. | REVISED | DATE | STANDARD DETAILS FOR PUBLIC WORKS CONSTRUCTION | SECTION: |
|-----|---------|------|--|----------|
| | | | | WASHOE |

TRENCH DETAIL SANITARY SEWER

DRAWING NO: WR-1.1

DATE: 7/09

PAGE: 1

7

SEWER & STORM DRAIN TRENCH DETAIL

SCALE: N.T.S.

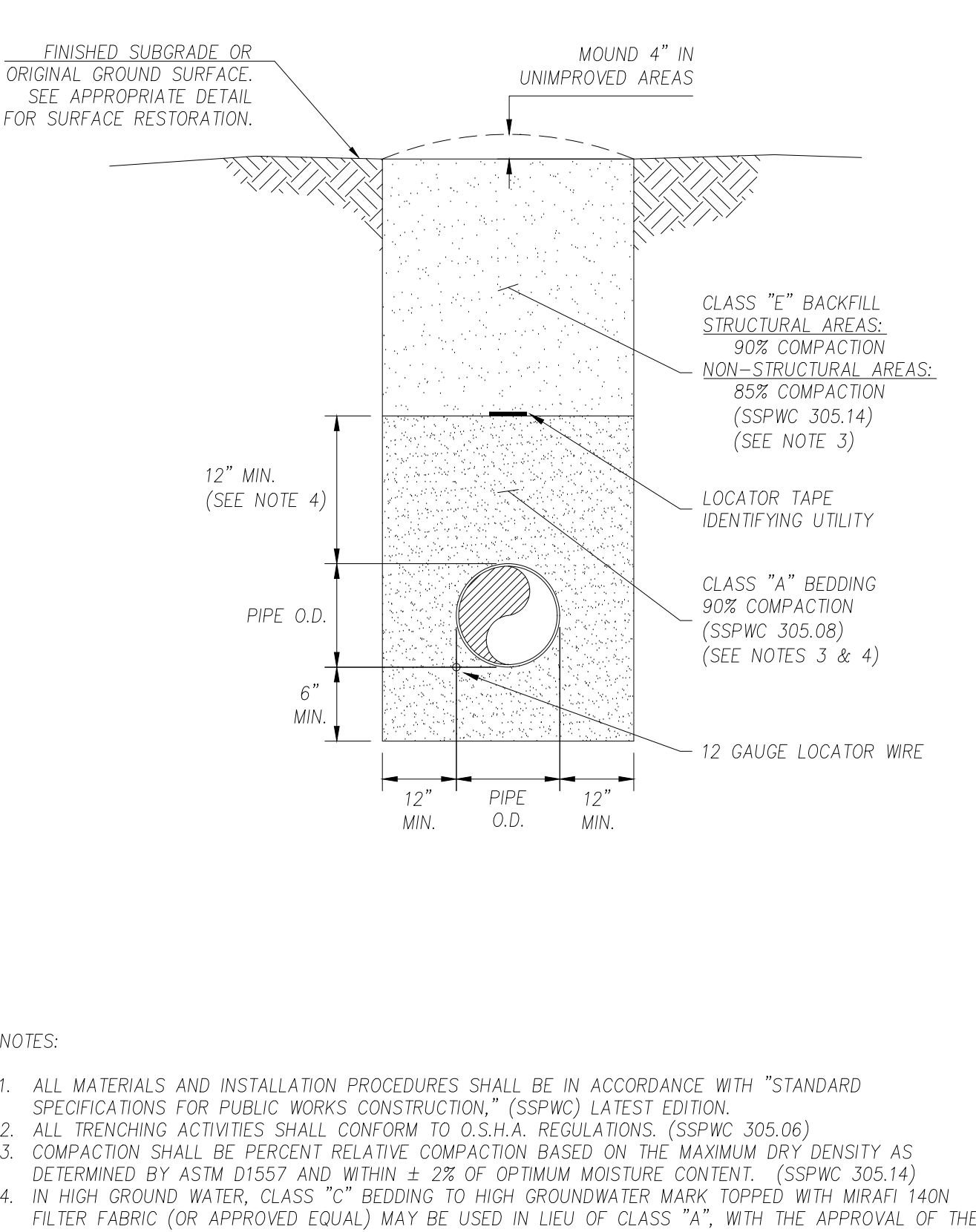

| NO. | REVISED | DATE | STANDARD DETAILS FOR PUBLIC WORKS CONSTRUCTION | SECTION: |
|-----|---------|------|--|----------|
| | | | | WASHOE |

TRENCH DETAIL WATER

DRAWING NO: WR-2.1

DATE: 7/09

PAGE: 10

8

WATER TRENCH DETAIL

SCALE: N.T.S.

AS SHOWN LUXELOCKER RENO 19042_C63

COPYRIGHT: GROUP AND MAY NOT BE REPRODUCED OR USED IN ANY CAPACITY WITHOUT THE WRITTEN AUTHORIZATION OF TECTONICS DESIGN GROUP.

DRAWN: N.D.J.
DESIGNED: N.D.J.
CHECKED/STAMPED: MATT K. RASMUSSEN, P.E.

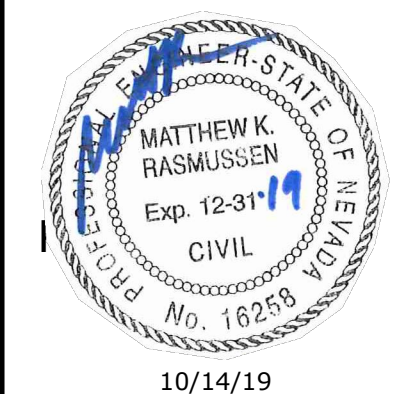

TECTONICS DESIGN GROUP

730 Sandhill Rd., #250, Reno, Nevada 89521
www.tectonicsdesigngroup.com
tel: 775-824-9988
fax: 775-824-9900

LUXELOCKER
11455 Digital Court, Spanish Springs, Nevada
Spanish Springs Storage Partners, LLC.
1845 McCulloch Blvd., Suite A6, Lake Havasu City, AZ.

| PROJECT/CLIENT: | DATE: | SUBMITTAL |
|-----------------|----------|-------------------------------|
| # 19042 | 6/24/19 | PERMIT SET |
| | 9/6/19 | PROGRESS SET |
| | 10/14/19 | WASHOE COUNTY REVIEW COMMENTS |

SHEET TITLE: DETAIL SHEET

C6.3

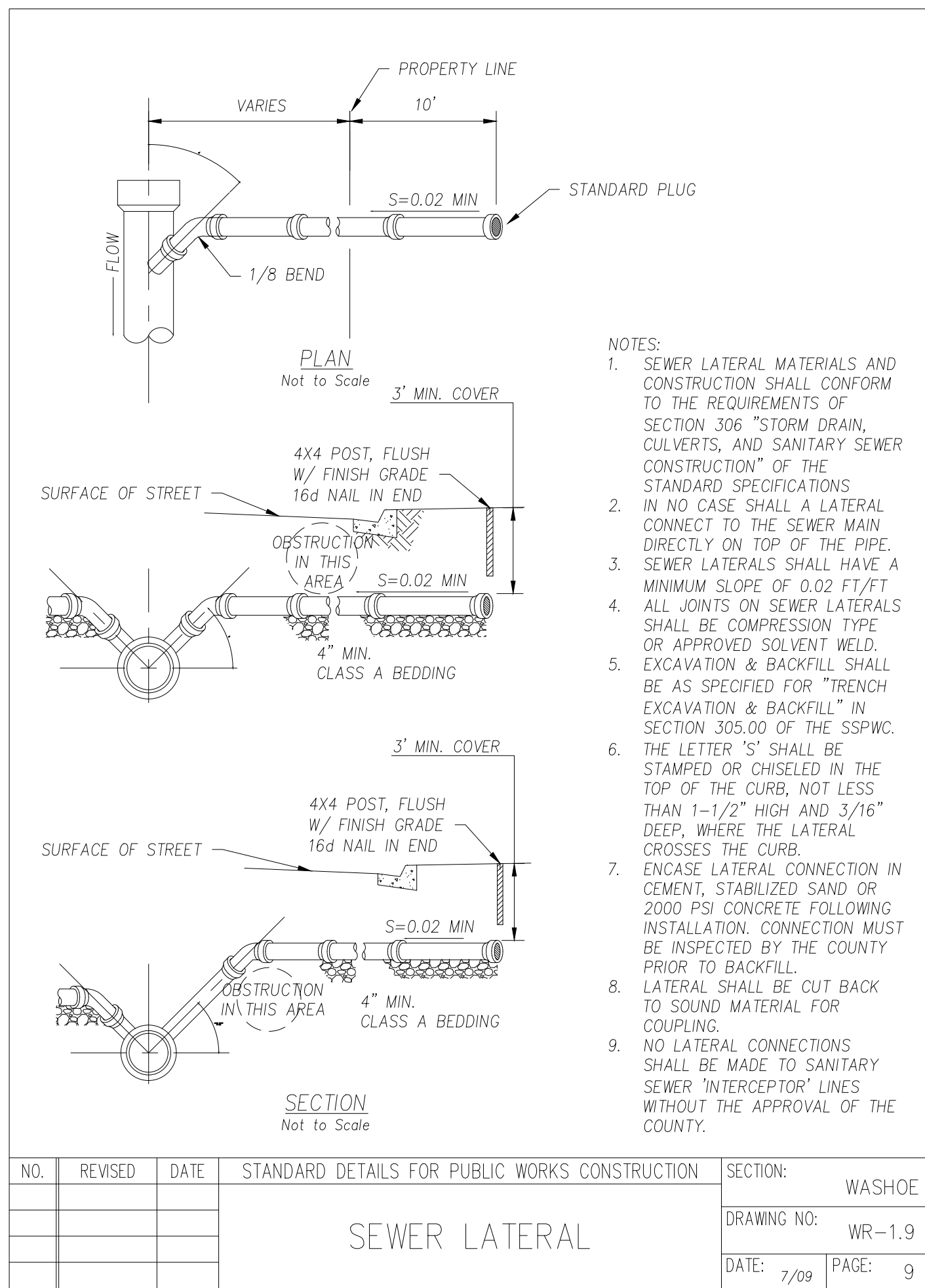

1 SEWER LATERAL DETAIL
SCALE: N.T.S.

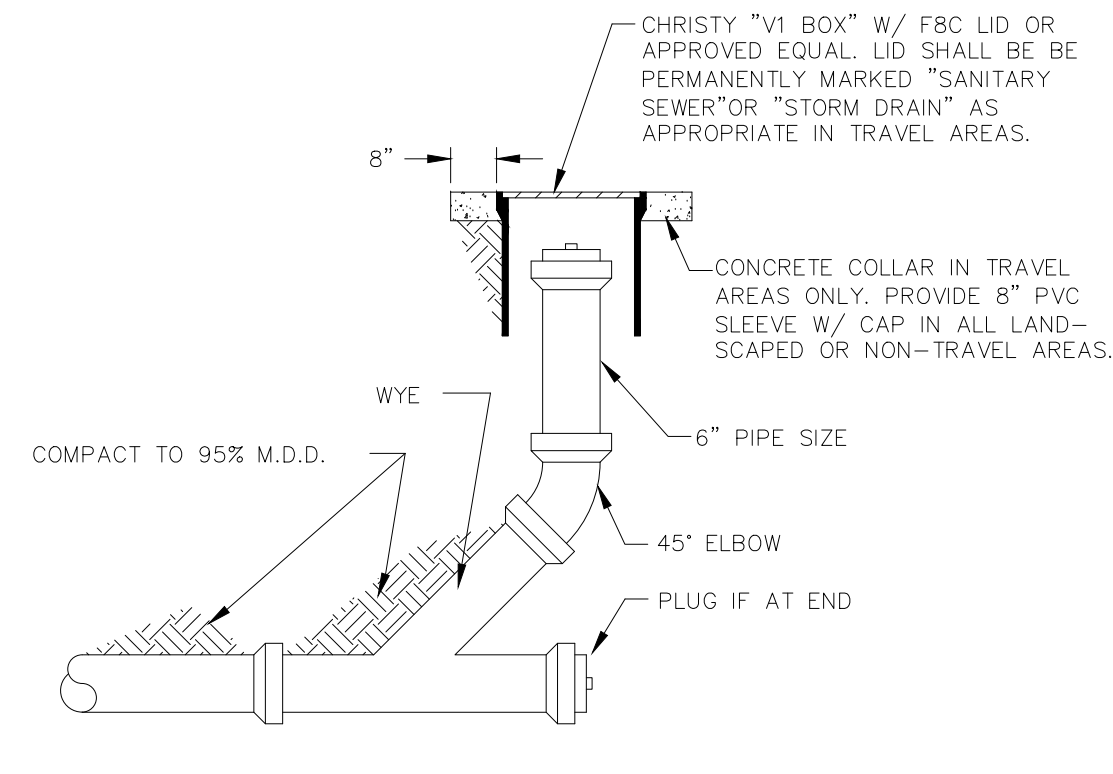

2 SEWER LATERAL CLEAN OUT
SCALE: N.T.S.

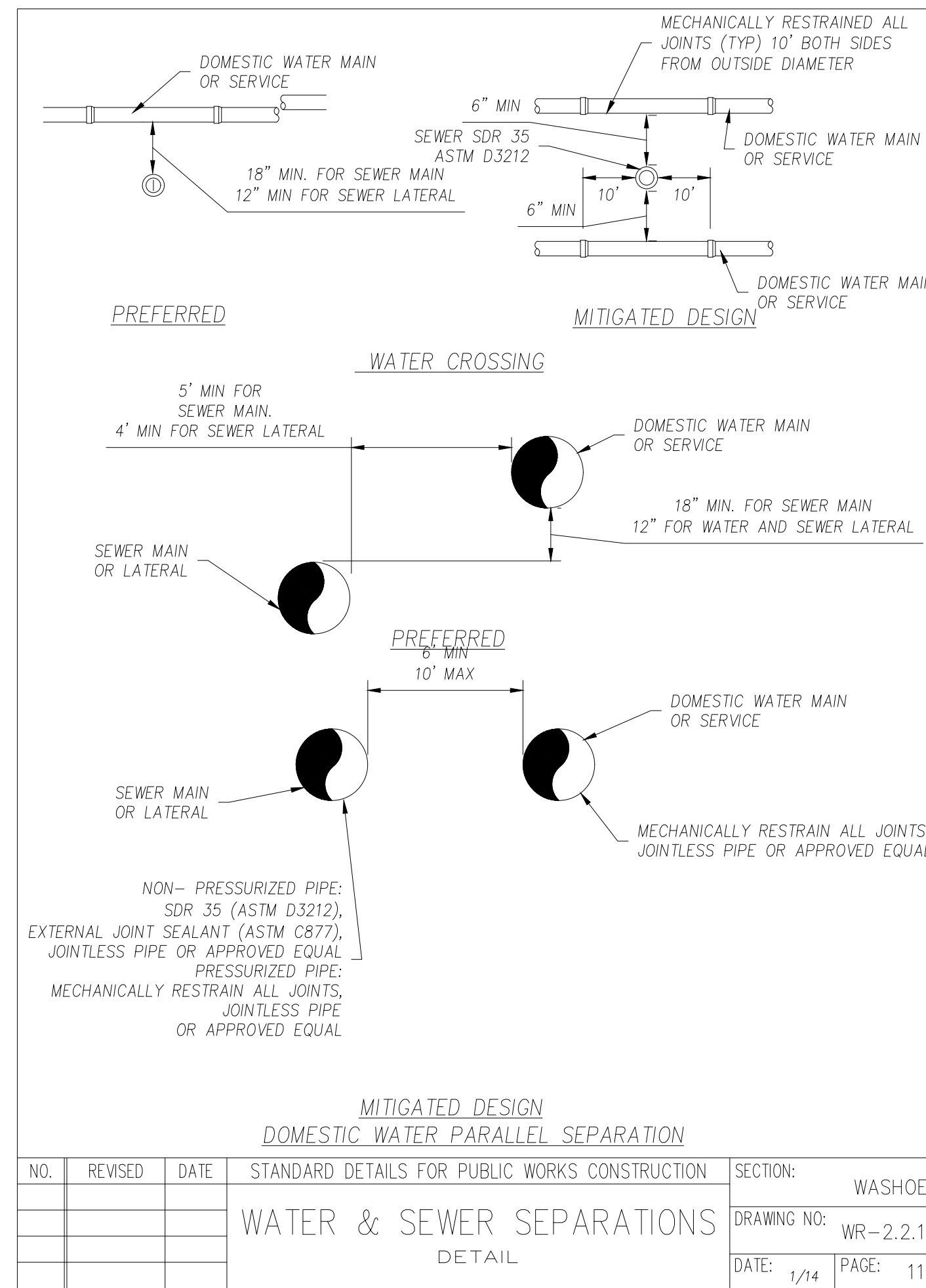

3 WATER & SEWER SEPARATION DETAIL
SCALE: N.T.S.

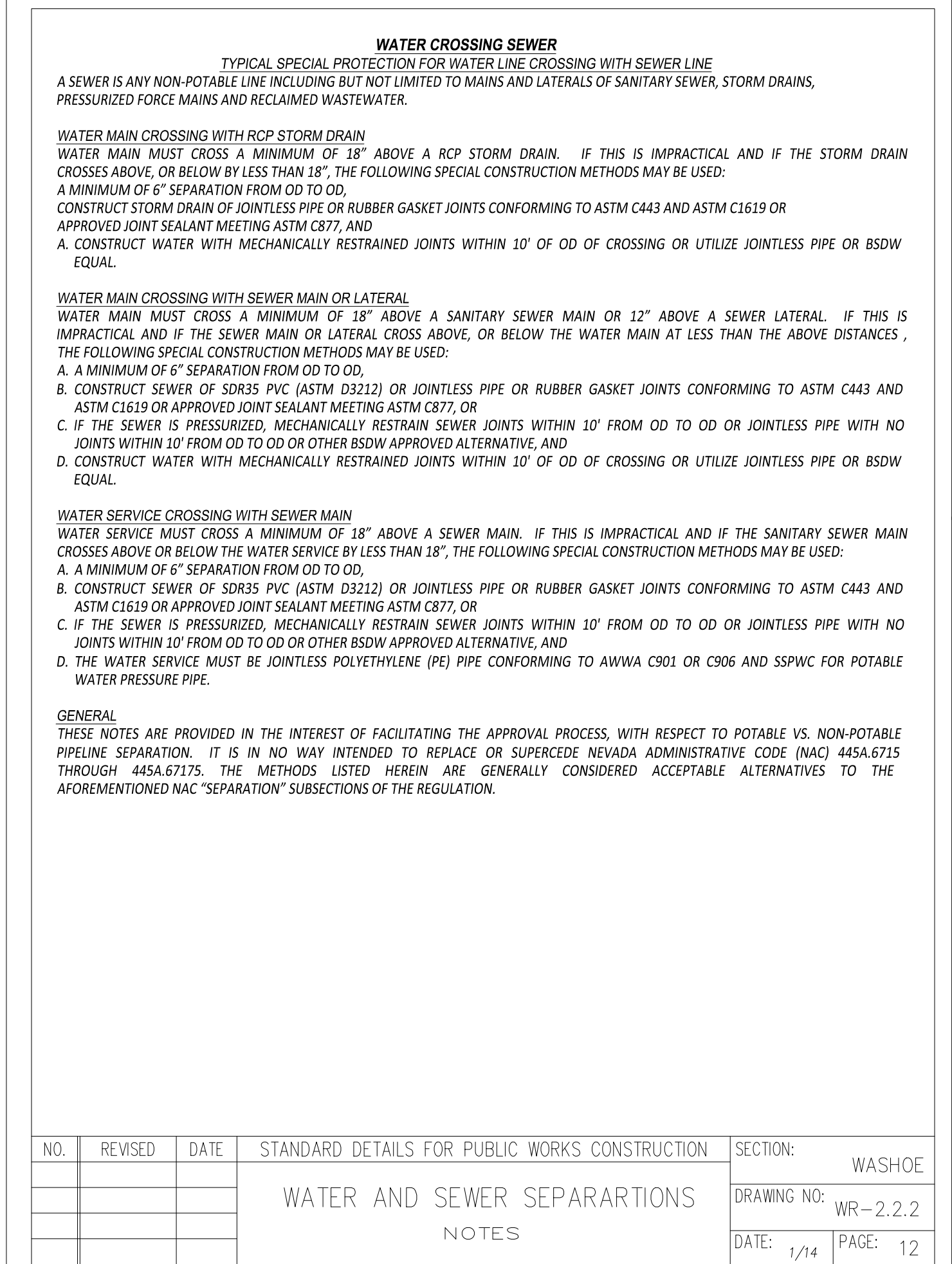

4 WATER & SEWER SEPARATION DETAIL
SCALE: N.T.S.

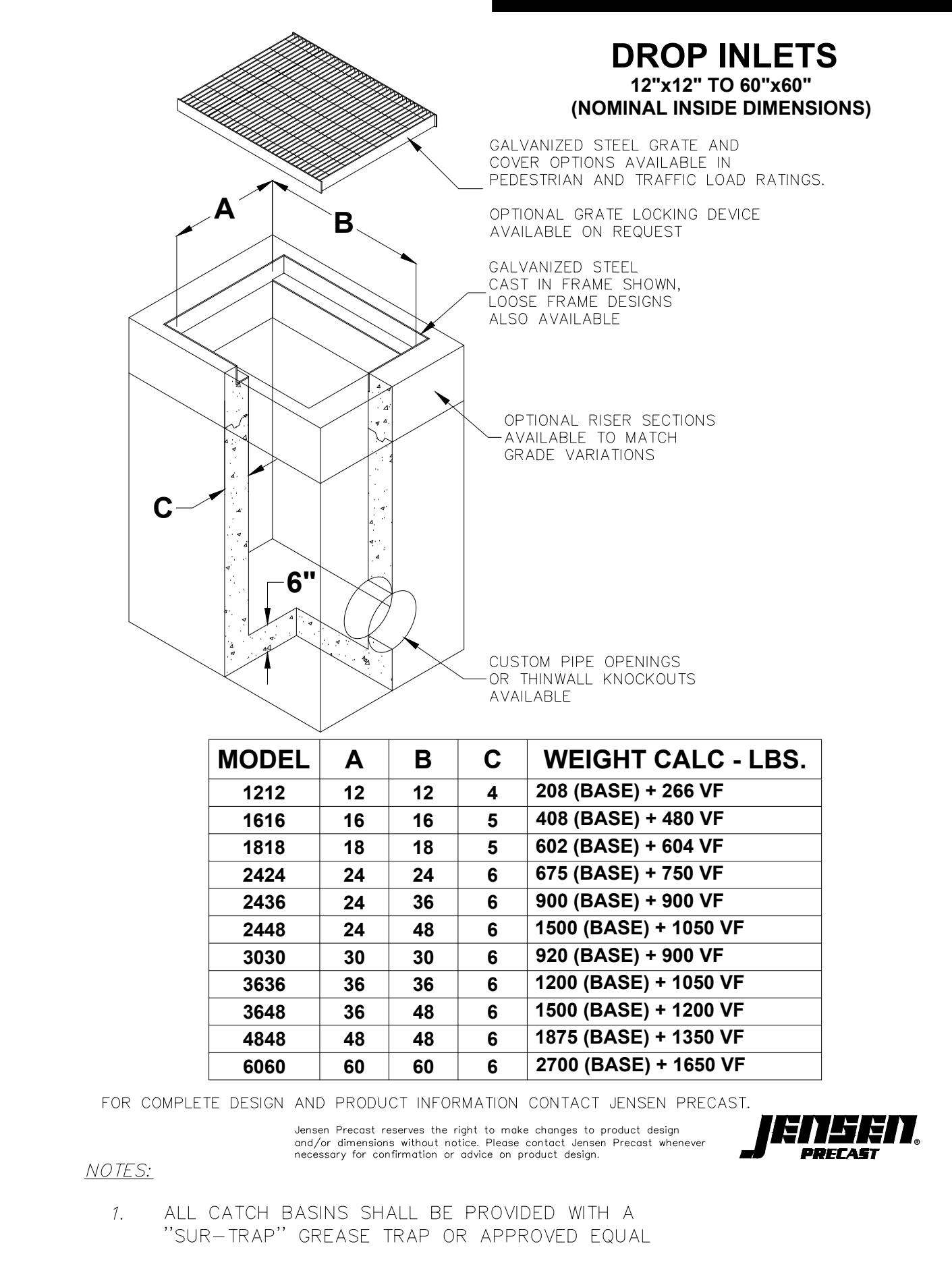

5 36"x36" TYPE 3R CATCH BASIN DETAIL
SCALE: N.T.S.

6 NOT USED
SCALE: N.T.S.

7 FIRE SERVICE TAP DETAIL
SCALE: N.T.S.

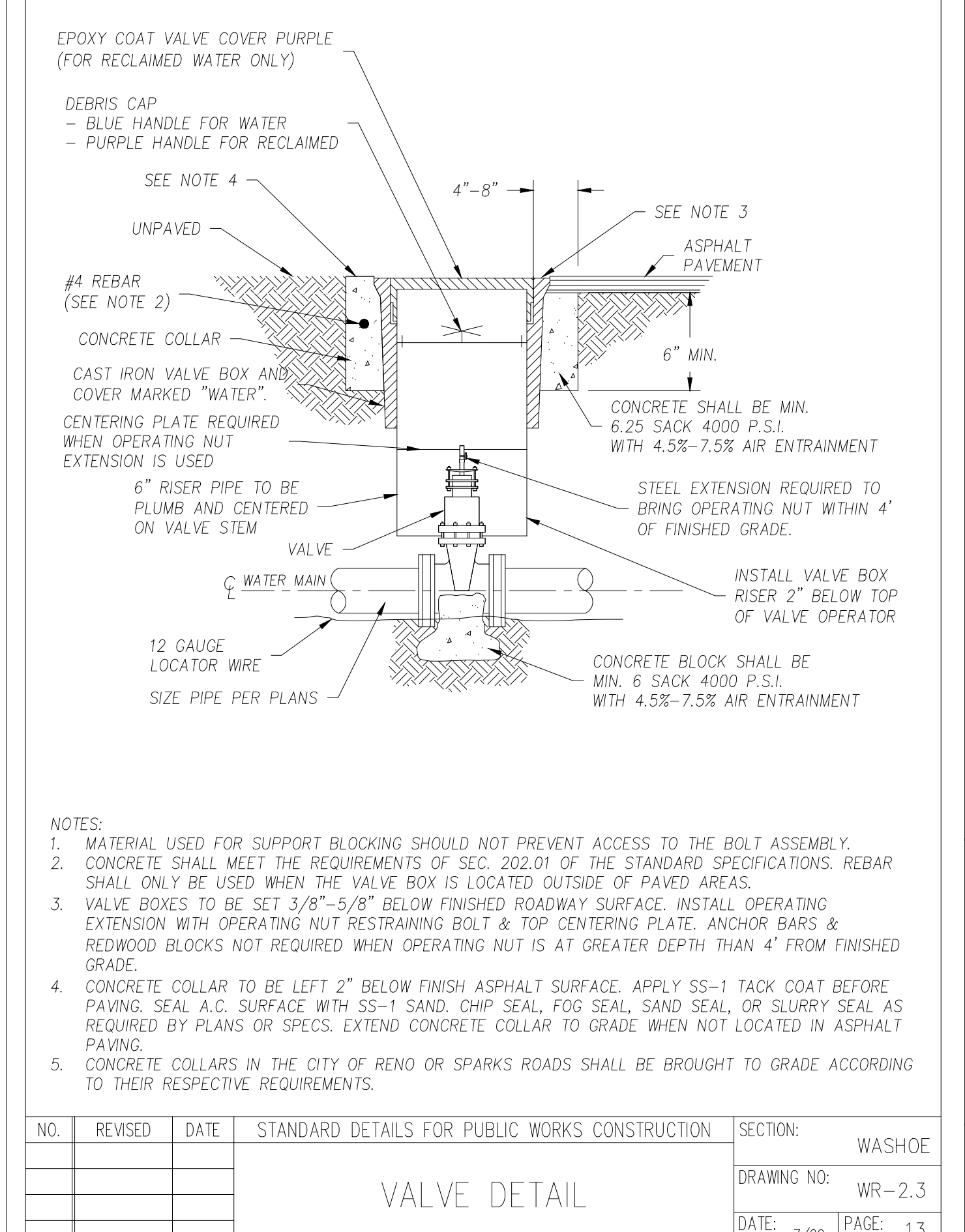

8 GATE VALVE DETAIL
SCALE: N.T.S.

ALL DRAWINGS HEREIN ARE THE PROPERTY OF TECTONICS DESIGN GROUP AND MAY NOT BE REPRODUCED OR USED IN ANY CAPACITY WITHOUT THE WRITTEN AUTHORIZATION OF TECTONICS DESIGN GROUP.

COPYRIGHT: TECTONICS DESIGN GROUP

DRAWN: N.D.J.
CHECKED/STAMPED: N.D.J.
MATT K. RASMUSSEN, P.E.

STATE OF NEVADA
MATTHEW K. RASMUSSEN
Exp. 12-31-14
CIVIL
No. 16269
10/14/19

DESIGNER: TECTONICS DESIGN GROUP

730 Sandhill Rd., #250, Reno, Nevada 89521
tel: 775-824-9988
fax: 775-824-9986
www.tectonicsdesigngroup.com

PROJECT/CLIENT: LUXELOCKER
19042
11455 Digital Court, Spanish Springs, Nevada
Spanish Springs Storage Partners, LLC.
1845 McCulloch Blvd., Suite A6, Lake Havasu City, AZ.

DATE: 6/24/19 SUBMITTAL
9/6/19 PERMIT SET
10/14/19 PROGRESS SET
WASHOE COUNTY REVIEW COMMENTS

SUBMITTAL RECORD: 19042

SHEET TITLE: VALVE DETAIL

DETAIL SHEET

C6.4

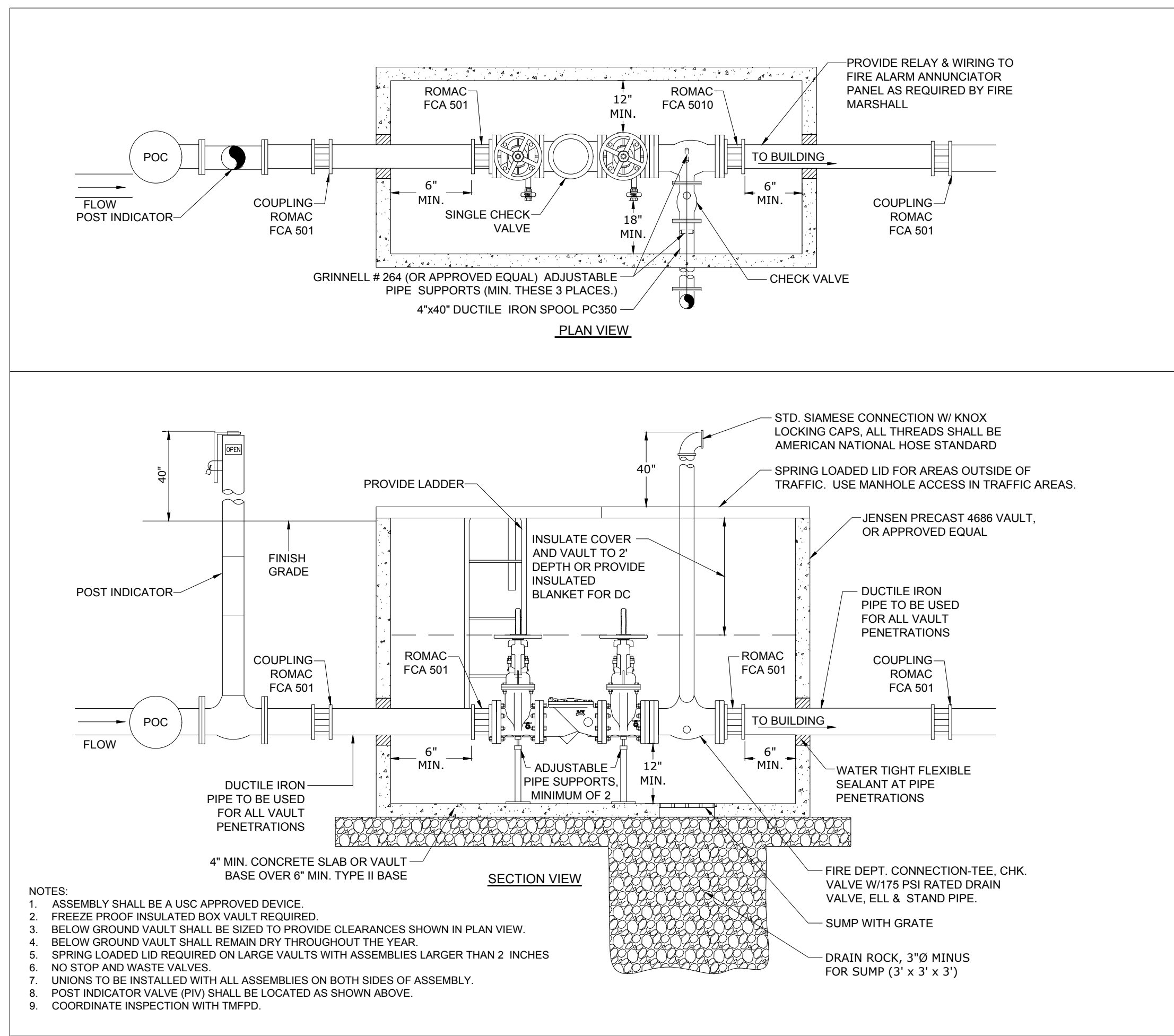

BELOW GRADE CHECK ASSEMBLY IN VAULT WITH PIV & FDC

1

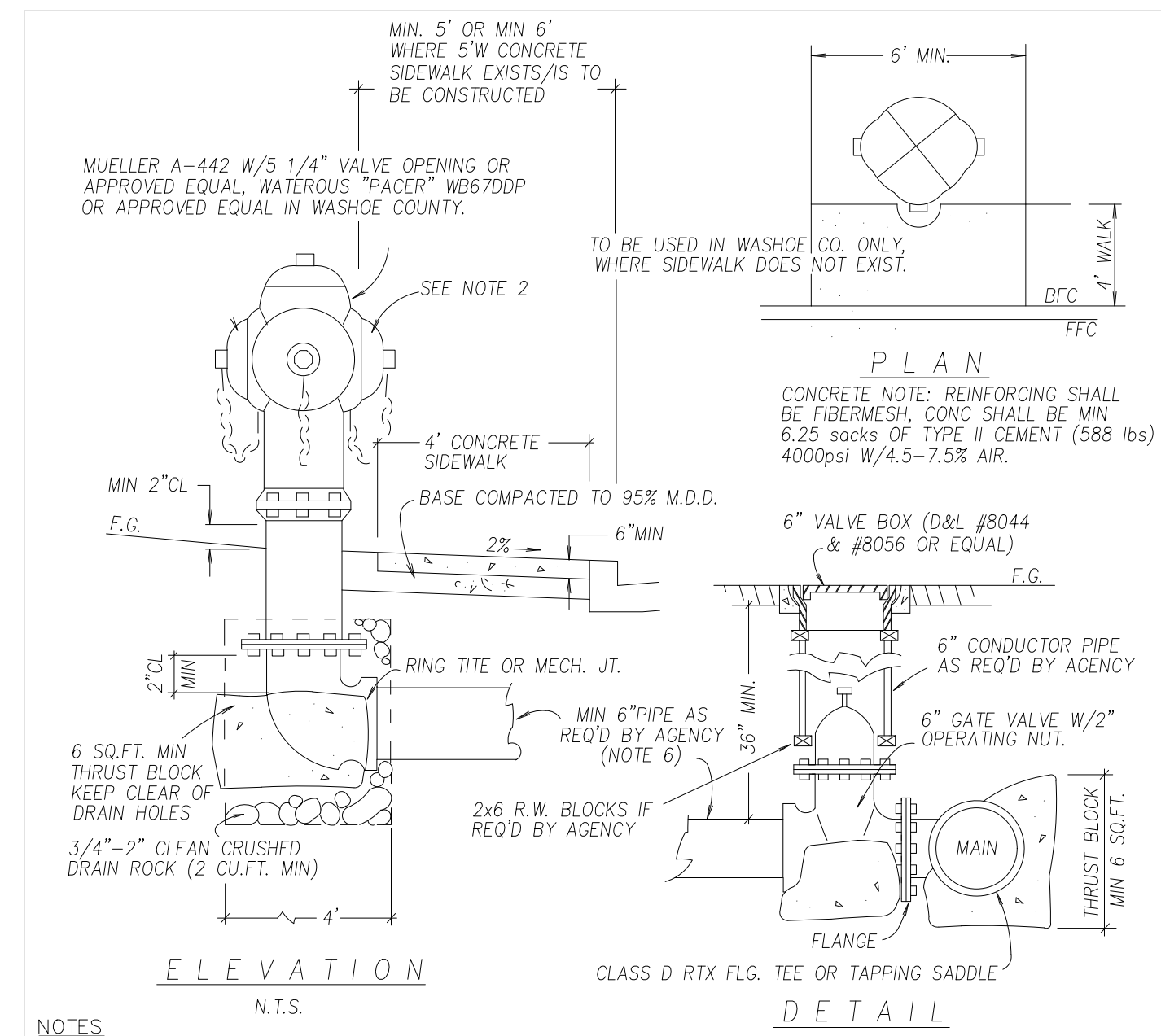

FIRE HYDRANT

2

FIRE HYDRANT ASSEMBLY DETAIL
SCALE: N.T.S.

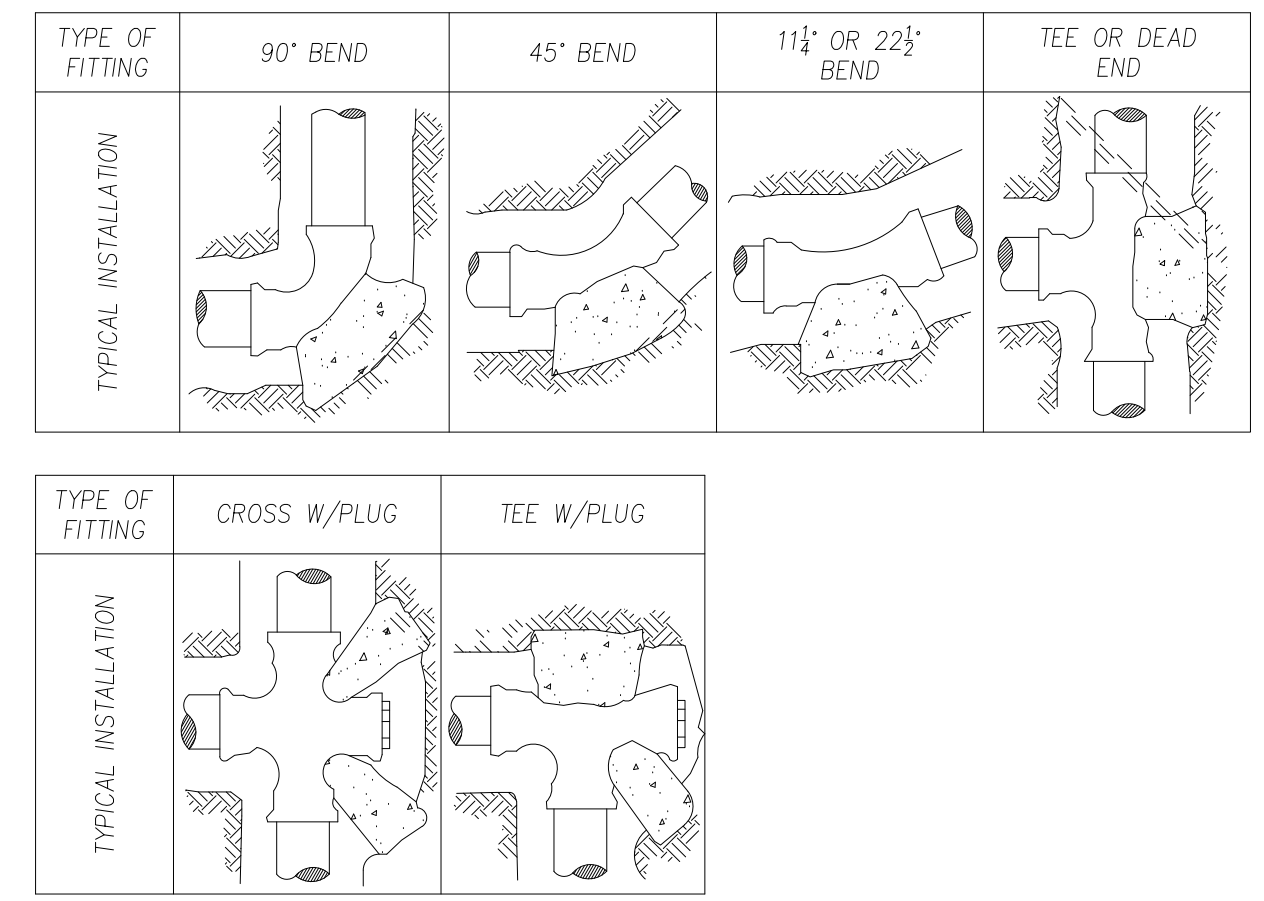

Table A.10.20-2013 Required Horizontal Bearing Block Area

| Nominal Pipe Diameter (in.) | Bearing Block Area (ft ²) | Nominal Pipe Diameter (in.) | Bearing Block Area (ft ²) | Nominal Pipe Diameter (in.) | Bearing Block Area (ft ²) |
|-----------------------------|---------------------------------------|-----------------------------|---------------------------------------|-----------------------------|---------------------------------------|
| 3 | 2.6 | 12 | 79.0 | 24 | 110.9 |
| 4 | 3.5 | 14 | 39.0 | 30 | 170.9 |
| 6 | 7.5 | 16 | 50.4 | 36 | 244.4 |
| 8 | 13.6 | 18 | 63.3 | 42 | 319.9 |
| 10 | 20.9 | 20 | 77.7 | 48 | 430.0 |

Notes:

- Although the bearing strength values in this table have been used successfully in the design of thrust blocks and are considered to be conservative, their accuracy is totally dependent on accurate soil identification and evaluation. The ultimate responsibility for selecting the proper bearing strength of a particular soil type must rest with the design engineer.
- Values listed are based on a 90-degree horizontal bend, an internal pressure of 100 psi, a soil horizontal bearing strength of 1000 lb/ft², a safety factor of 1.5, and ductile iron pipe outside diameters.
- For other horizontal bends, multiply by the following coefficients: for 45 degrees, 0.941; for 22.5 degrees, 0.926; for 11.25 degrees, 0.896.
- For other internal pressures, multiply by ratio to 100 psi.
- For other soil horizontal bearing strengths, divide by ratio to 1000 lb/ft².
- For other safety factors, multiply by ratio to 1.5.

Example: Using Table A.10.20-2013, find the horizontal bearing block area for a 6 in. diameter, 45-degree bend with an internal pressure of 150 psi. The soil bearing strength is 800 lb/ft² and the safety factor is 1.5.

From Table A.10.20-2013, the required bearing block area for a 6 in. diameter, 90-degree bend with an internal pressure of 100 psi and a soil horizontal bearing strength of 1000 psi is 2.6 ft².

For example:

$$2.6 \text{ ft}^2 \left(\frac{0.941}{1.5} \right) \left(\frac{150}{100} \right) \left(\frac{800}{1000} \right) = 2.1 \text{ ft}^2$$

Pressure and Bearing Strength Conversion

| Pipe Diameter | 10 in |
|-----------------|----------|
| Soil Bearing | 3000 PSF |
| System Pressure | 175 PSI |

Thrust Block Area

| Elbow Angle | (ft ²) |
|-------------|--------------------|
| 90 | 12.0 |
| 45 | 6.5 |
| 22.5 | 3.2 |
| 11.25 | 1.7 |

3

THRUST BLOCK DETAIL
SCALE: N.T.S.

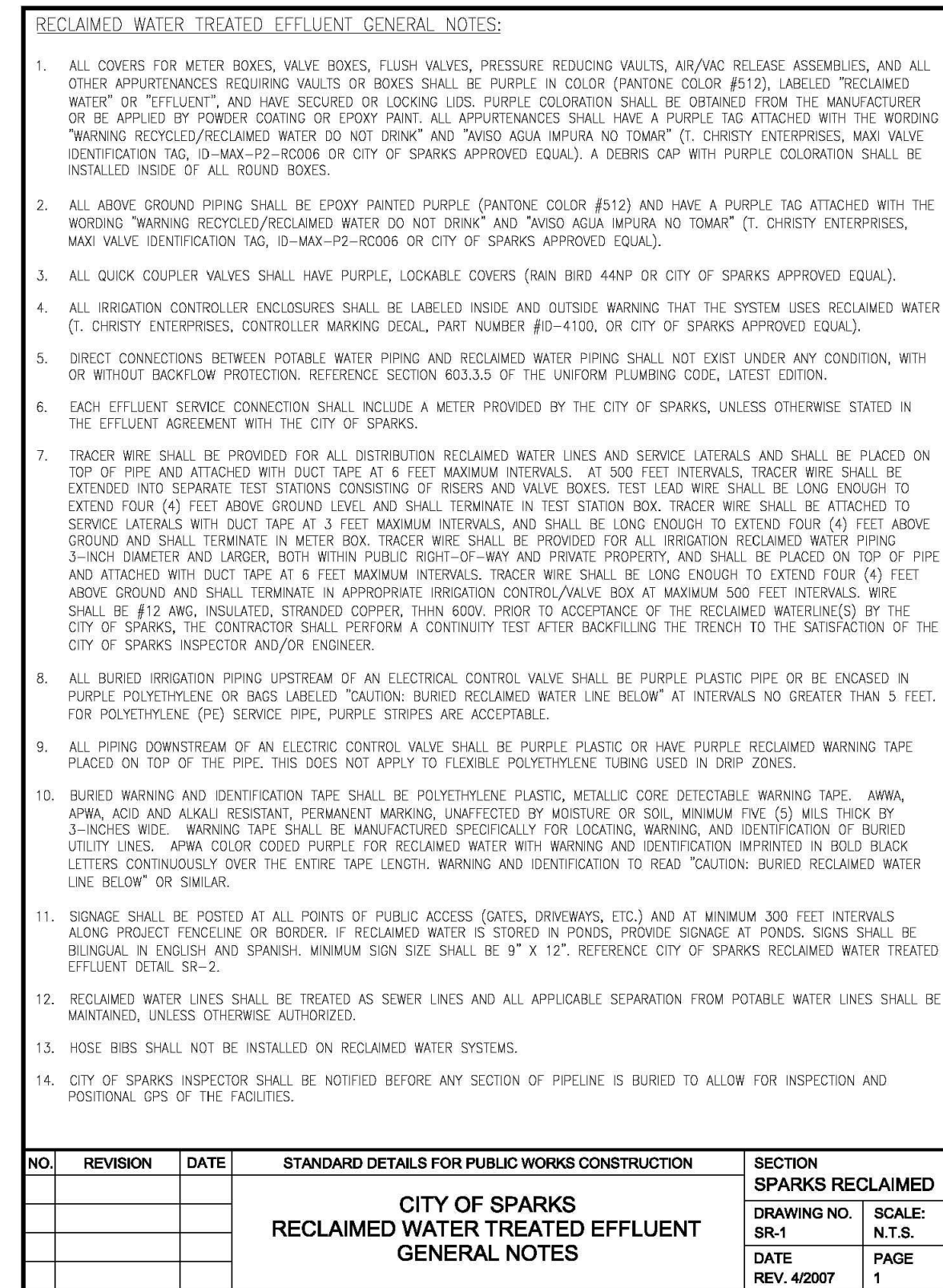

4

RECLAIMED WATER NOTES
SCALE: N.T.S.



5

RECLAIMED WATER SIGNAGE
SCALE: N.T.S.

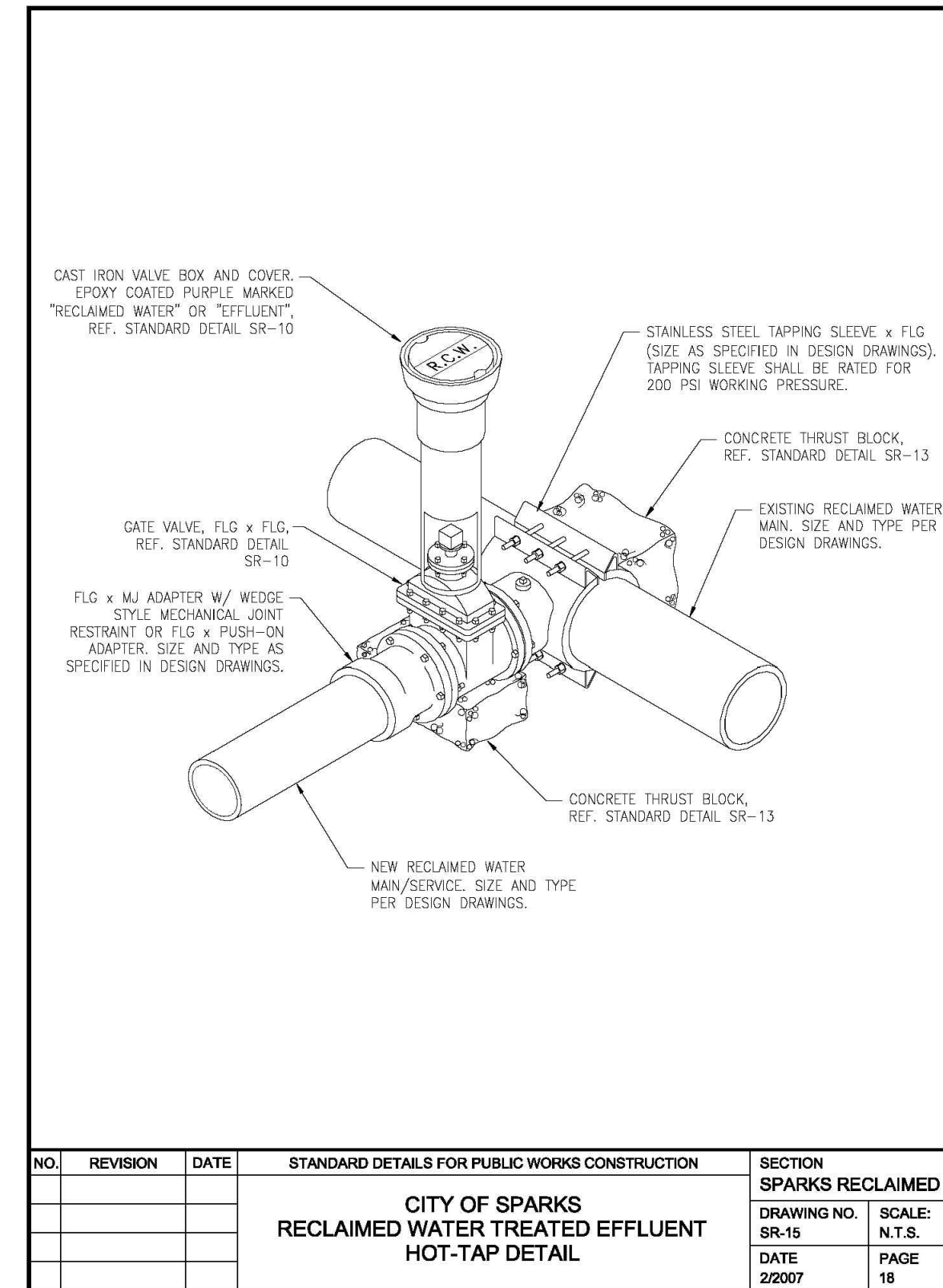

6

RECLAIMED WATER HOT TAP DETAIL
SCALE: N.T.S.

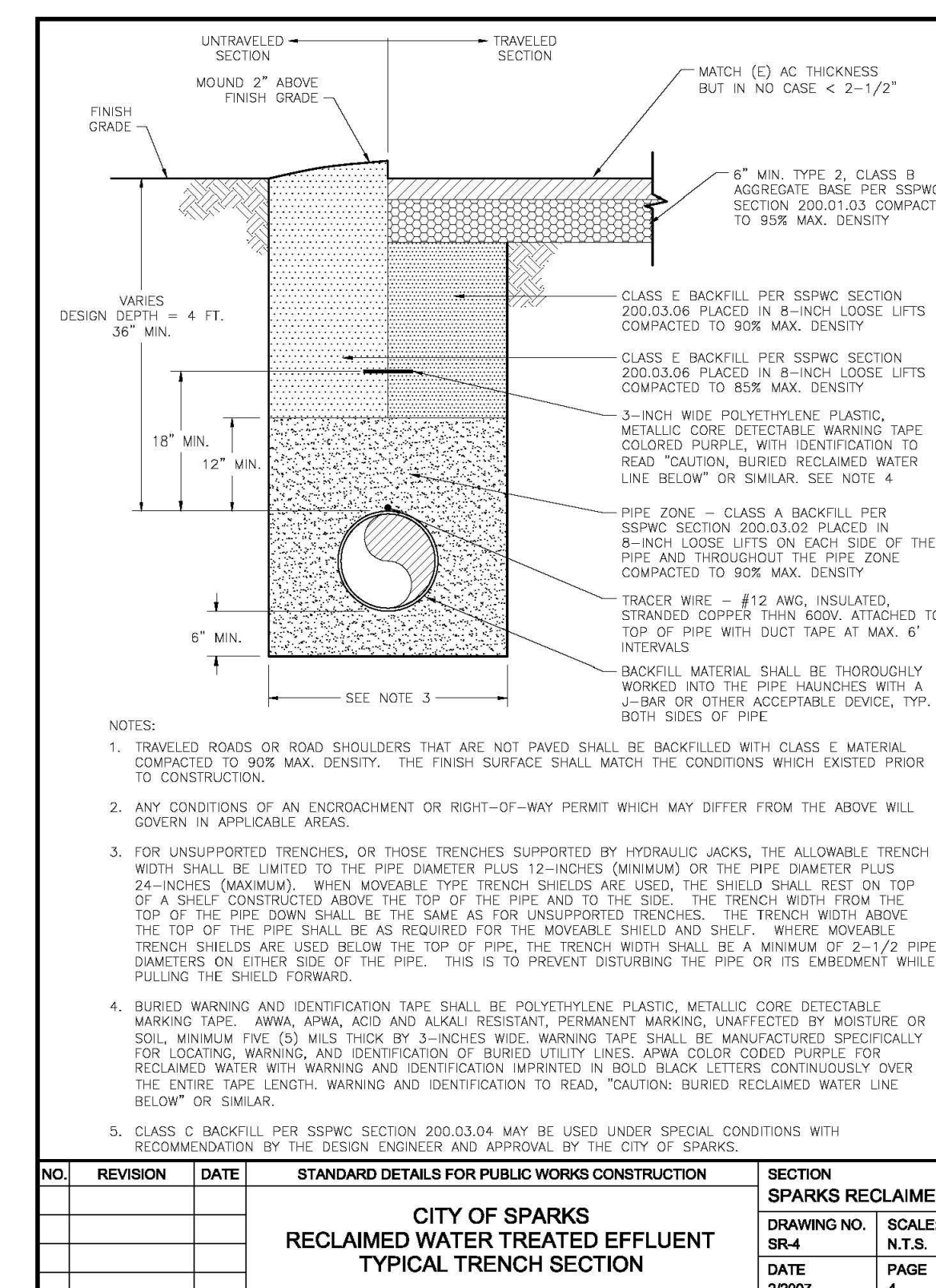

7

RECLAIMED WATER TRENCHING DETAIL
SCALE: N.T.S.

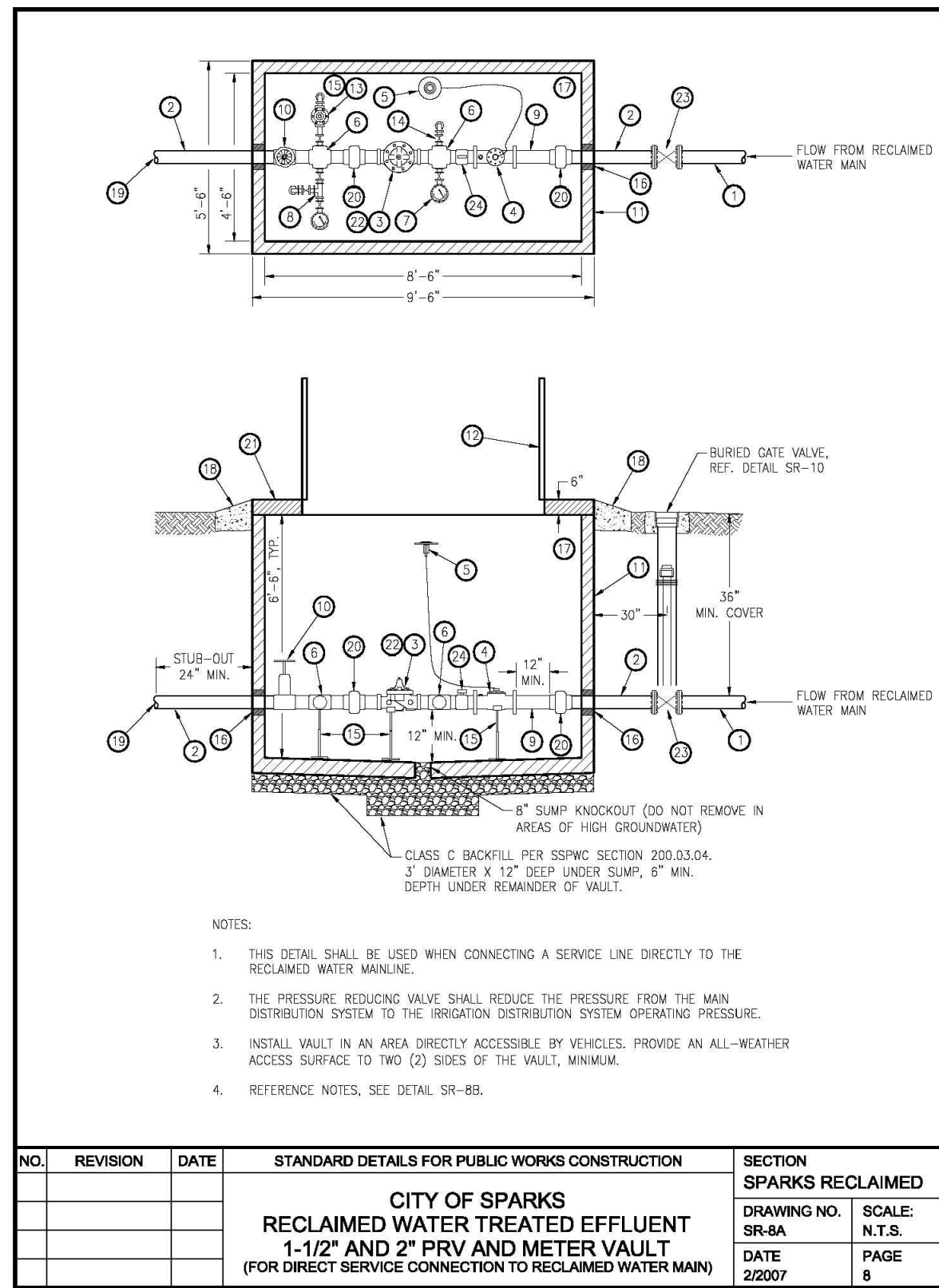

1 RECLAIMED WATER METER DETAIL
SCALE: N.T.S.

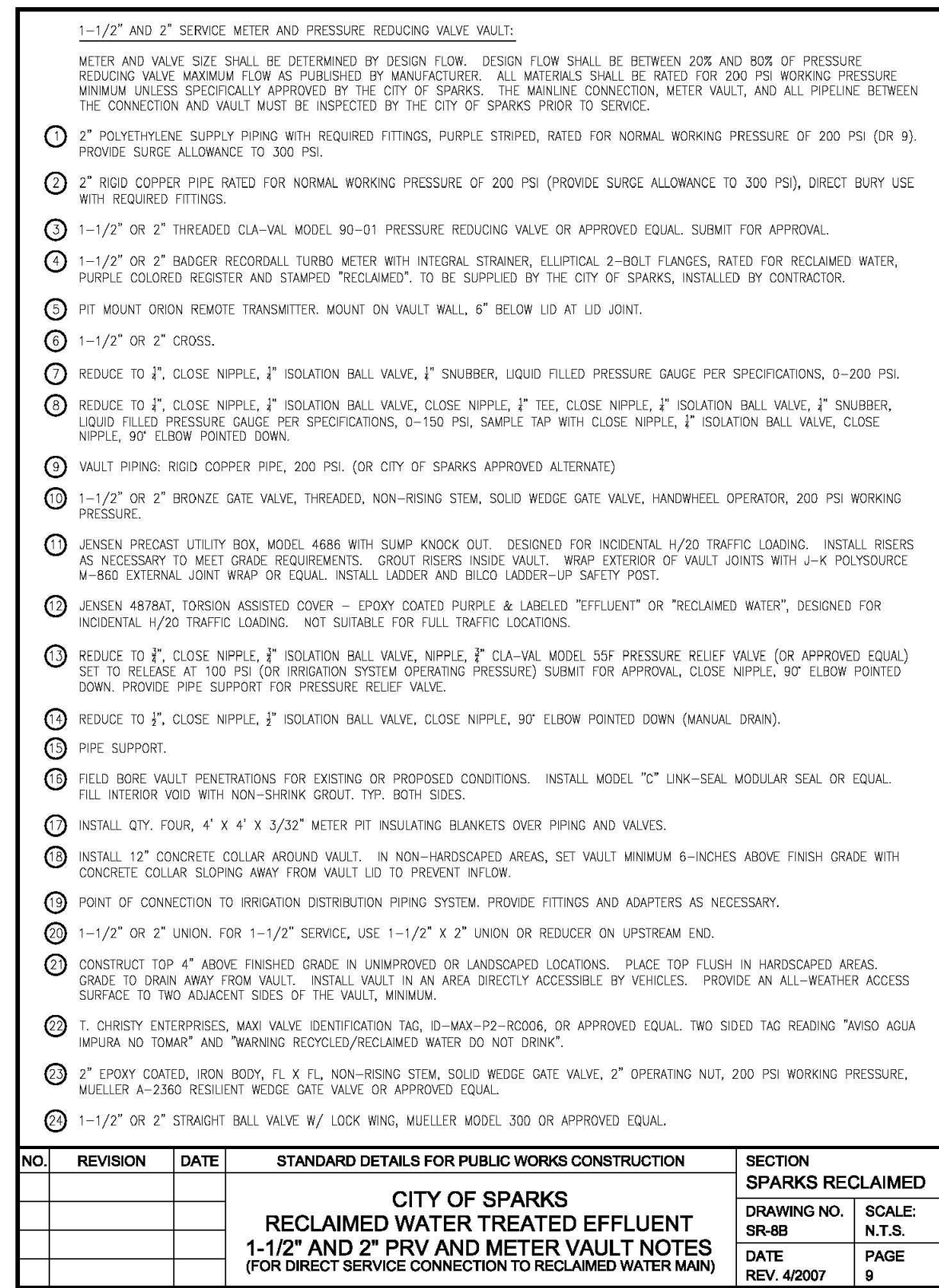

2 RECLAIMED WATER METER GENERAL NOTES
SCALE: N.T.S.

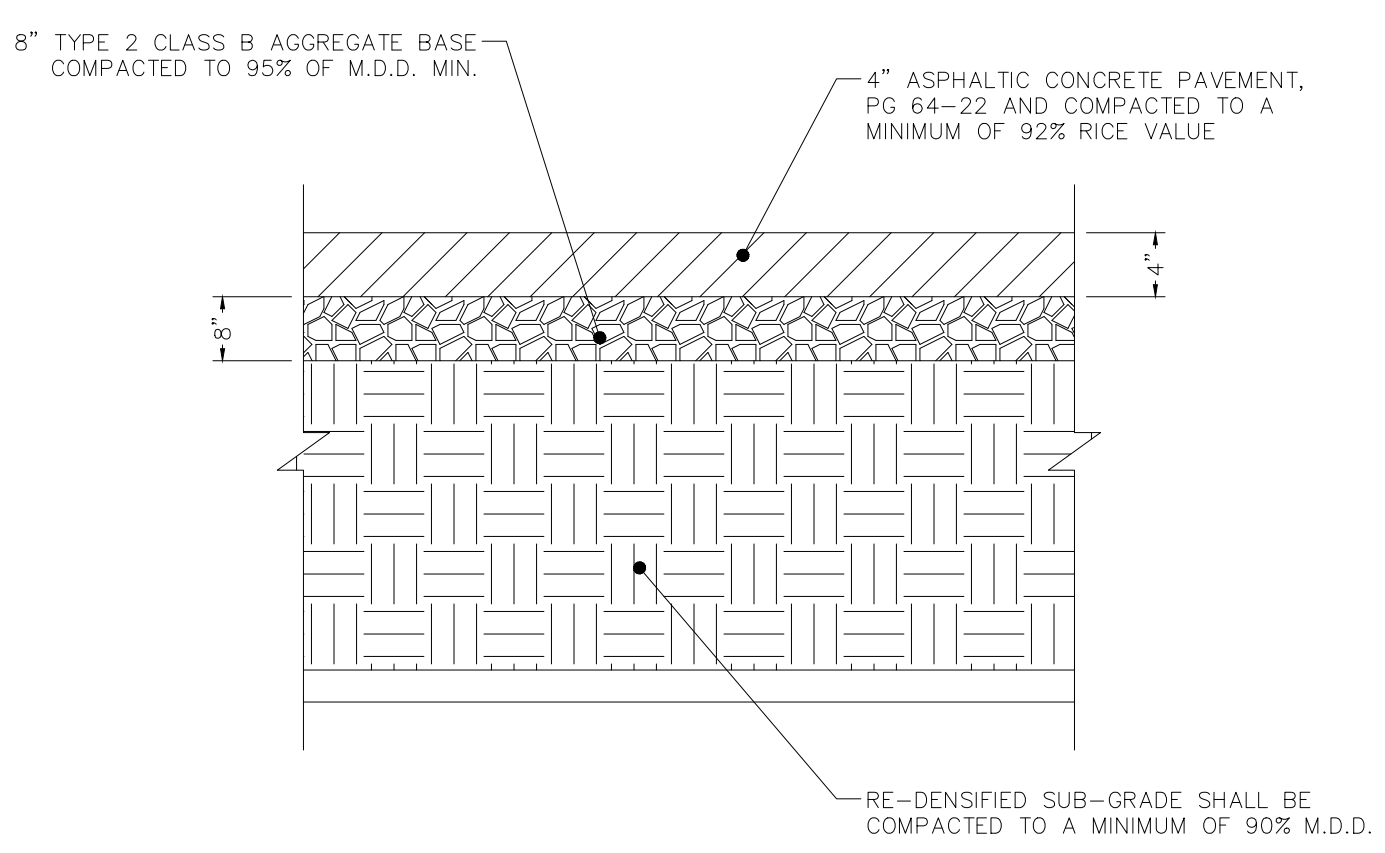

3 AC PAVING DETAIL
SCALE: N.T.S.

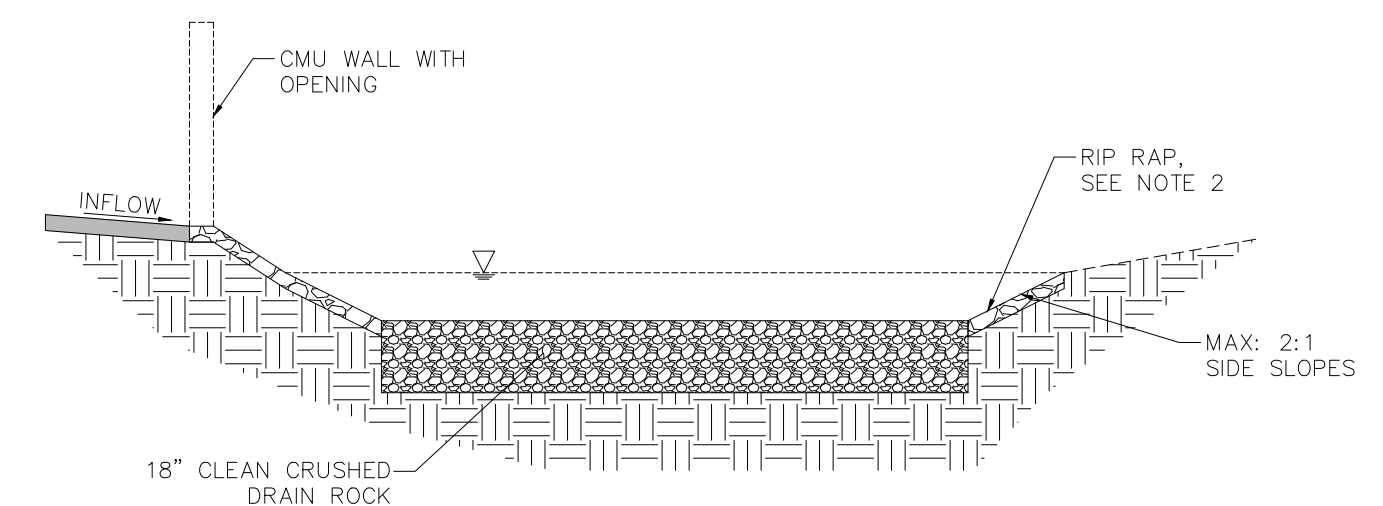

4 INFILTRATION BASIN
SCALE: N.T.S.

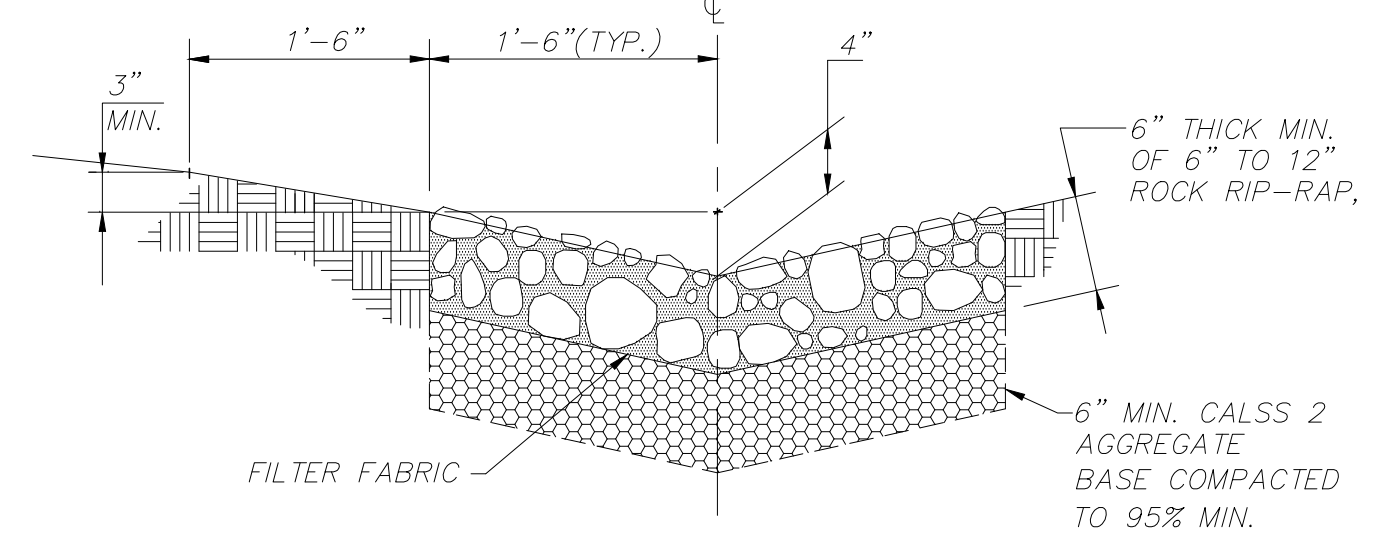

5 RIP RAP LINED SWALE
SCALE: N.T.S.

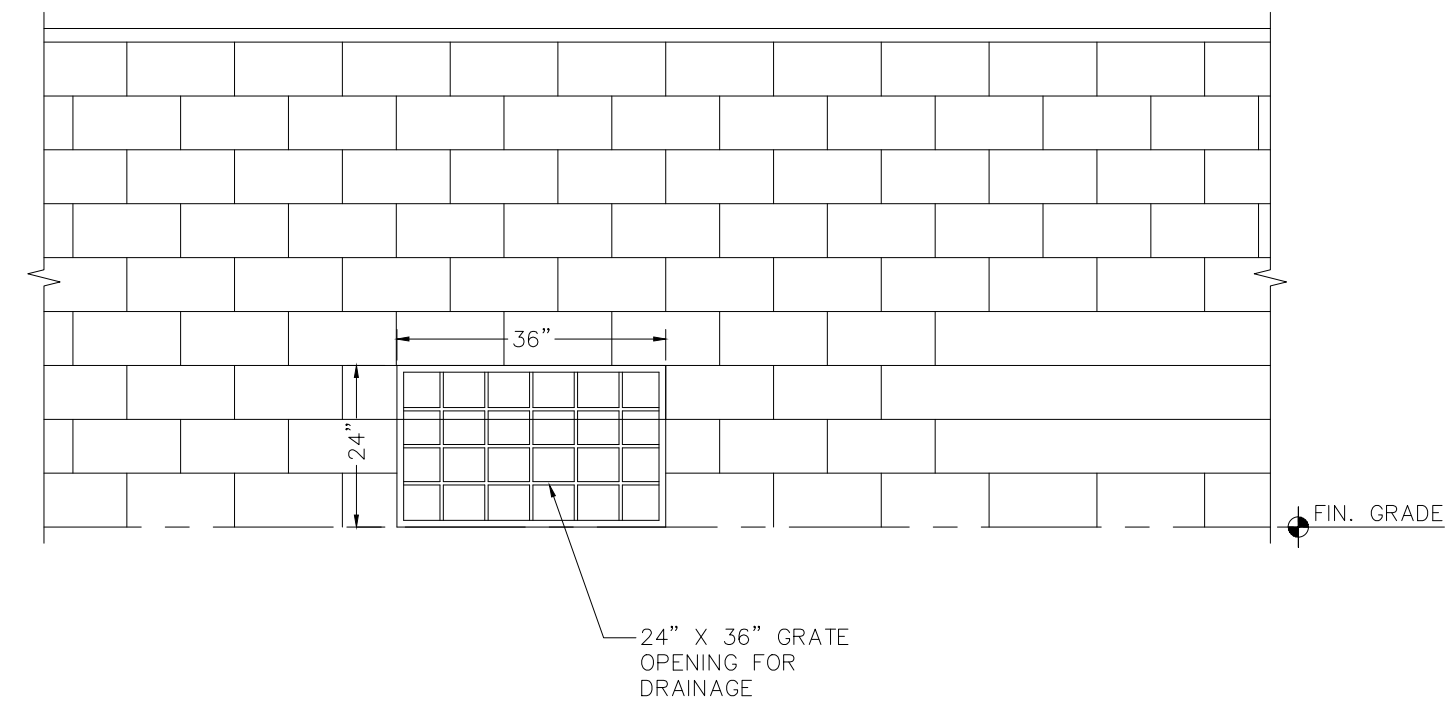

6 CMU DRAINAGE OPENING
SCALE: N.T.S.

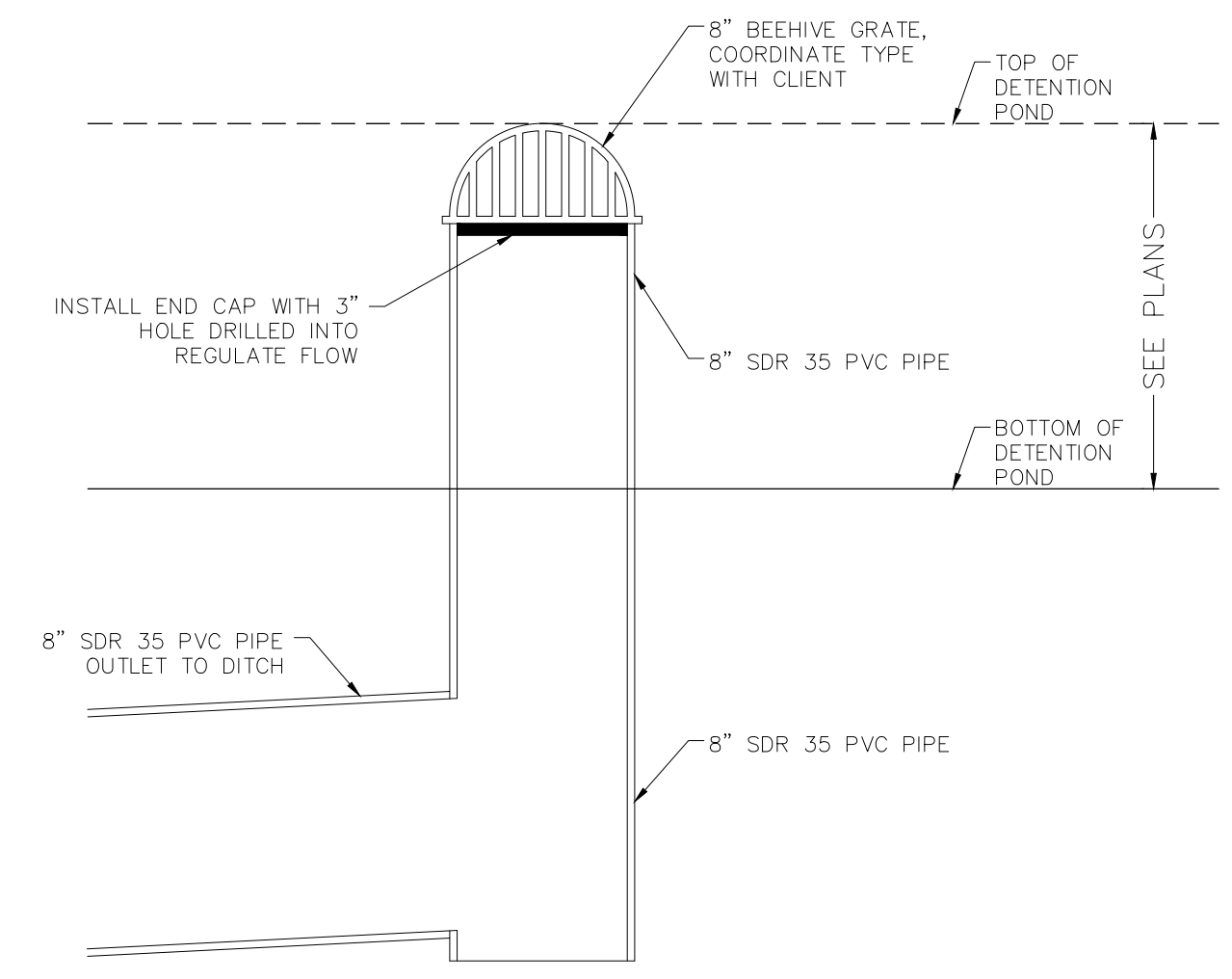

7 DETENTION POND OUTLET DETAIL
SCALE: N.T.S.

8 NOT USED
SCALE: N.T.S.

AS SHOWN LUXELOCKER RENO 19042_C66

COPYRIGHT: All drawings herein are the property of Tectonics Design Group and may not be reproduced or used in any capacity without the written authorization of Tectonics Design Group.

DRAWN: N.D.J.
DESIGNED: N.D.J.
CHECKED/STAMPED: MATT K. RASMUSSEN, P.E.

10/14/19

DESIGNER: TECTONICS DESIGN GROUP
730 Sandhill Rd., #250, Reno, Nevada 89521
Tel: 775-824-9988 Fax: 775-824-9986
www.tectonicsdesigngroup.com

PROJECT/CLIENT: LUXELOCKER
11455 Digital Court, Spanish Springs, Nevada
Spanish Springs Storage Partners, LLC.
1845 McCulloch Blvd., Suite A6, Lake Havasu City, AZ.

PROJECT #: 19042

DATE: 6/24/19
SUBMITTAL RECORD: 9/6/19
10/14/19

SUBMITTAL RECORD: SUBMITTAL PERMIT SET
PROGRESS SET
WASHOE COUNTY REVIEW COMMENTS

SHEET TITLE: DETAIL SHEET

SHEET: C6.6

Copyright: All drawings herein are the property of Tectonics Design Group and may not be reproduced or used in any capacity without the written authorization of Tectonics Design Group.

DRAWN: KH
 DESIGNED: BH
 CHECKED/STAMPED: BARBARA M. HATCH RLA ASLA

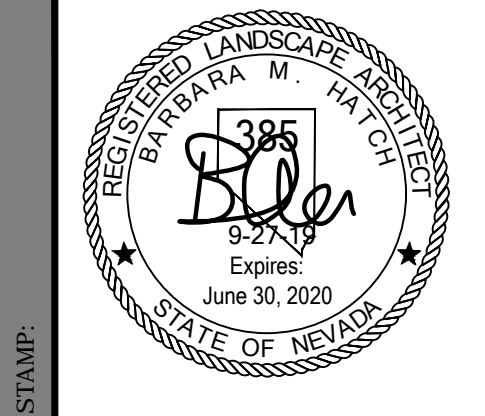

DESIGNER: **TECTONICS DESIGN GROUP**
 730 Sandhill Rd., #250, Reno, Nevada 89521
 tel 775-824-9988
 fax 775-824-9986
 www.tectonicsdesigngroup.com

PROJECT CLIENT: **LUXELOCKER**
 11455 Digital Court, Spanish Springs, Nevada
Consolidated Construction Co Inc.
 Appleton, WI

PROJECT NUMBER: # 19042
 DATE: 6/21/19
 SUBMITTAL RECORD: SUBMITTAL RECORD
 SHEET TITLE: LANDSCAPE PLAN

SHEET: L1.1

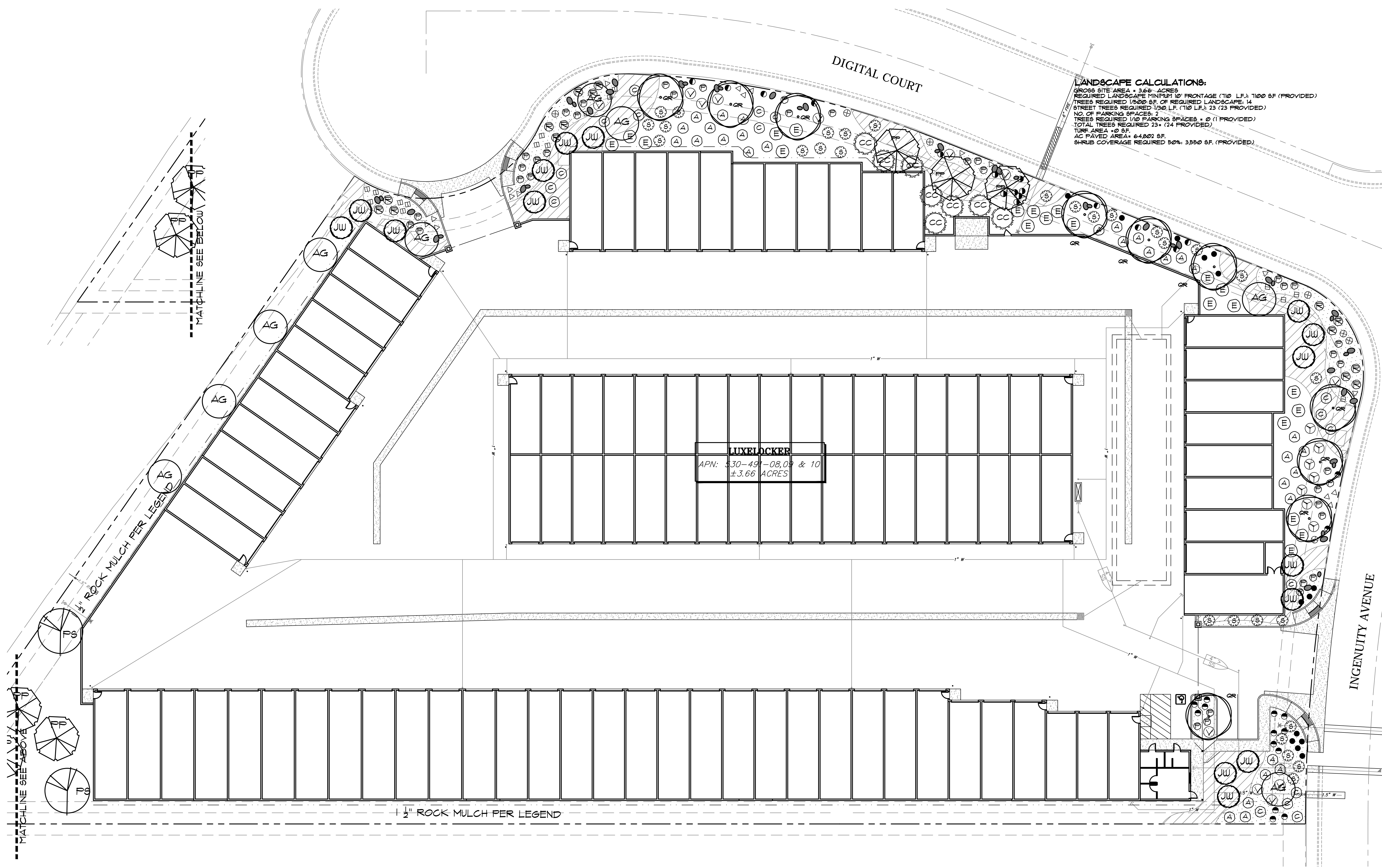

LANDSCAPE CALCULATIONS:
 GROSS SITE AREA = 3.66 ACRES
 REQUIRED LANDSCAPE MINIMUM 10' FRONTAGE (110 LF.) 1100 SF (PROVIDED)
 TREES REQUIRED 1/800 SF OF REQUIRED LANDSCAPE: 14
 STREET TREES REQUIRED 1/20 LF. (110 LF.): 23 (23 PROVIDED)
 NO. OF PARKING SPACES: 2
 TREES REQUIRED 1/10 PARKING SPACES = 0 (1 PROVIDED)
 TOTAL TREES REQUIRED 23 + (24 PROVIDED)
 TURF AREA = 0 SF
 AC PAVED AREA = 64,802 SF
 SHRUB COVERAGE REQUIRED 50%: 3,250 SF. (PROVIDED)

LUXELOCKER
 APN: 330-491-08, 09 & 10
 ± 3.66 ACRES

SEE SHEET L1.2 FOR PLANT LIST

GreenDesign Landscape Architects, Inc.
 Barbara M. Hatch ASLA
 Nevada License No. 385
 1464 Popinjoy Drive
 Reno, Nevada
 89509
 phone 775.829.1364
 fax 775.829.1364
 BHatch00@charter.net

LANDSCAPE PLAN
 SCALE: 1" = 20'-0"

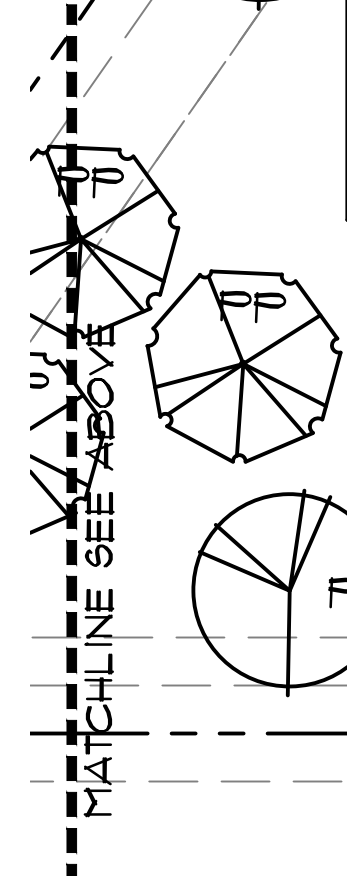
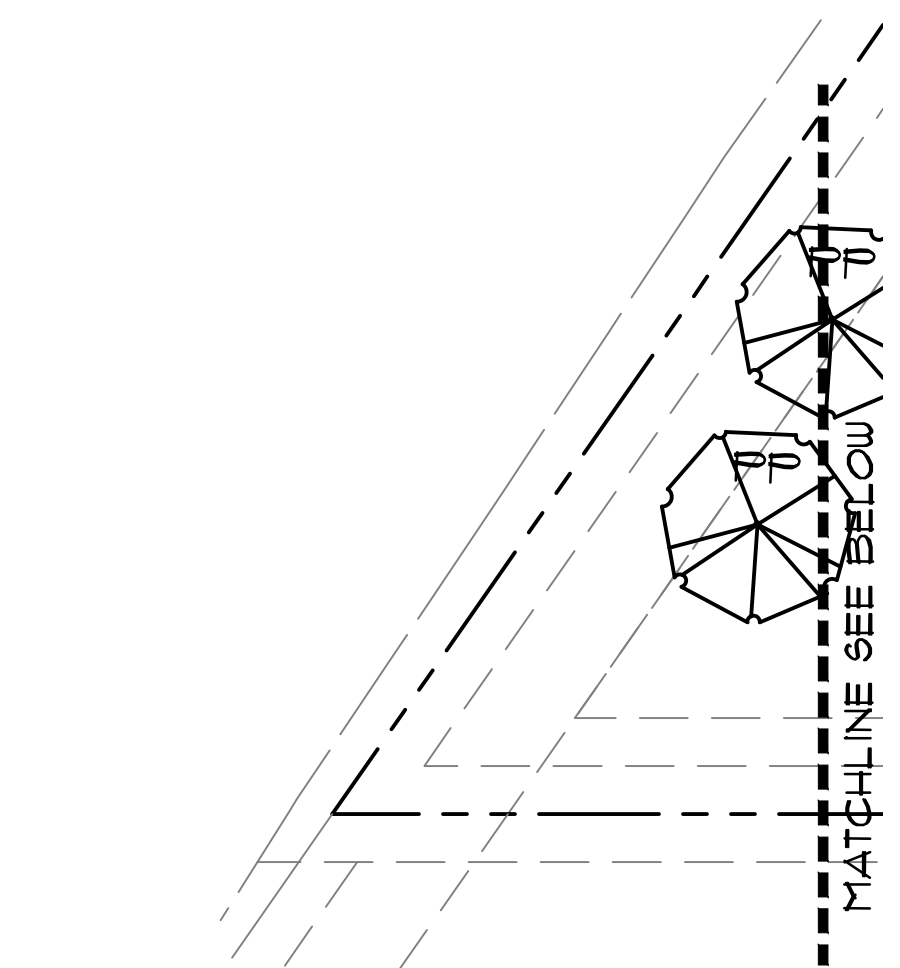
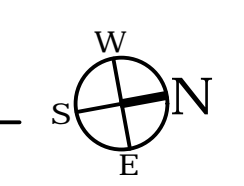

1/2" ROCK MULCH PER LEGEND

1/2" ROCK MULCH PER LEGEND

PLANT LIST:

| KEY NO. | BOTANICAL NAME | COMMON NAME | SIZE | REMARKS |
|------------------------|-----------------------------------|-----------------------|------------------|--------------------------|
| DECIDUOUS TREES | | | | |
| QR 10 | QUERCUS MACROCARPA | BUR OAK | 24" BOX OR B 4 B | 2' MIN. CAL. MATCHED |
| AG 9 | ACER GINNALA 'FLAME' | AMUR MAPLE | 15 GAL. | 1 1/4' MIN. CAL. MATCHED |
| EVERGREEN TREES | | | | |
| FP 6 | FINUS NIGRA | AUSTRIAN PINE | 15 GAL. OR B 4 B | 6' MIN. HEIGHT |
| FS 3 | FICEA FUNGENS GLAUCA | COLORADO BL. SPRUCE | 15 GAL. OR B 4 B | 6' MIN. HEIGHT |
| JW 15 | CUPRESSUS ARIZONICA | ARIZONA CYPRESS | 15 GAL. OR B 4 B | 6' MIN. HEIGHT |
| SHRUBS | | | | |
| S 29 | FRUNUS BESSEYI | SAND CHERRY | 5 GAL. | 24' MIN. HEIGHT |
| A 31 | RHUS TRILOBATA | SQUAWBUSH SUMAC | 5 GAL. | 24' MIN. SPREAD |
| C 17 | CYTISUS P. 'MOONLIGHT' | MOONLIGHT BROOM | 5 GAL. | 18' MIN. SPREAD |
| P 37 | FINUS MUGO 'SHERWOOD COMPACT' | DW. MUGO PINE | 5 GAL. | 18' MIN. SPREAD |
| R 15 | POTENTILLA 'FROSTY' | POTENTILLA | 5 GAL. | 18' MIN. SPREAD |
| Y 7 | CARYOPTERIS | BLUE MIST | 1 GAL. | 12' MIN. HEIGHT |
| CC 8 | COTINUS C. 'ROYAL PURPLE' | SMOKE TREE | 5 GAL. | MULTI-STEMMED MATCHED |
| E 22 | LONICERA TARTARICA | TARTARIAN HONEYSUCKLE | 5 GAL. | 24' MIN. HEIGHT |
| PERENNIALS | | | | |
| ▽ 11 | ACHILLEA M. 'MOONSHINE' | YARROW | 1 GAL. | 12' MIN. SPREAD |
| ● 14 | ZAUSCHNERIA CALIFORNICA | CALIF. FUSCHIA | 1 GAL. | 12' MIN. HEIGHT |
| ⊕ 7 | CERASTIUM TOMENTOSUM | SNOW IN SUMMER | 1 GAL. | 12' MIN. SPREAD |
| ∨ 12 | PEROVSKIA 'BLUE SPIRE' | RUSSIAN SAGE | 1 GAL. | 12' MIN. HEIGHT |
| GRASSES | | | | |
| ▣ 16 | MISCANTHUS SINENSIS 'GRACILLIMUS' | MAIDEN GRASS | 1 GAL. | 12' MIN. HEIGHT |
| ○ 26 | CALAMAGROSTIS A. 'KARL FOERSTER' | FEATHERREED | 1 GAL. | 12' MIN. HEIGHT |

LANDSCAPE LEGEND



ROCK MULCH:
ALL PLANTERS NOT DESIGNATED FOR ROCK ACCENT OR D.S. MULCH AREA W/ 3" MIN. DEPTH OF 1/2" FRACTURED ROCK, COLOR GRAY TO TAN.
PLACE OVER WATER PERMEABLE DEWITT PRO 5 LANDSCAPE FABRIC, INSTALL PER MFG. SPEC. PLACE SHREDDED BARK MULCH IN ALL PLANT BASINS. REFER TO DETAIL SHEET L-3.1

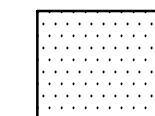

DECOMPOSED GRANITE:
ALL PLANTERS AS SHOWN.
3" MIN. DEPTH OF DECOMPOSED GRANITE PLACE OVER WATER PERMEABLE DEWITT PRO 5 LANDSCAPE FABRIC, INSTALL PER MFG. SPEC. RAKE SMOOTH, NET AND COMPACT.

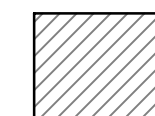

ROCK ACCENT: 3" MIN. DEPTH OF 3"-6" FRACTURED GRAY TO TAN. COLOR TO BLEND WITH ROCK MULCH PLACE OVER WATER PERMEABLE DEWITT PRO 5 LANDSCAPE FABRIC, INSTALL PER MFG. SPEC. PLACE SHREDDED BARK MULCH IN ALL PLANT BASINS. REFER TO DETAIL SHEET L-3.1

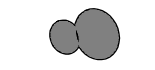

2'-4" DIA. BOULDERS FRACTURED ROCK MATCH BLEND COLOR WITH MULCH. REFER TO DETAIL SHEET L-3.1

SAMPLES OF MULCH SHALL BE SUBMITTED TO THE OWNER FOR APPROVAL PRIOR TO DELIVERY TO THE SITE. ROCK MULCHES SHALL BE WASHED AND CLEAN OF DIRT AND DEBRIS PRIOR TO DELIVERY TO THE SITE. TREAT ALL PLANTERS WITH PRE-EMERGENT HERBICIDE PRIOR TO INSTALLING FABRIC. (SEEDED AREA EXCLUDED)

NOTE:
MAINTAIN 3' CLEAR AROUND ALL FIRE HYDRANTS. PLANTS SHALL BE FIELD PLACED FOR PLANTING TO ALLOW FOR MATURE HABIT TO BE MINIMUM OF 3' CLEAR OF HYDRANTS.

NOTE:
8' TREE OR LARGER PROVIDE WIRE CABLE GUYING OF TREE. TRIFLE GUY WIRES EQUAL DISTANCE AROUND TREE, ANCHOR 8' FROM CENTER OF TREE. SUBMIT PRE-MANUFACTURED GUY SYSTEM OR PLAN OF FABRICATED SYSTEM FOR APPROVAL PRIOR TO INSTALL. WIRE TO BE 1/2" GALVANIZED CABLE WITH TURN BUCKLE FOR TIGHTENING. WIRE CLAMPS TO SECURE. STAKES MIN. OF 30' EMBEDDMENT AT 45 DEGREE ANGLE. PROTECT TREE WITH TUBING OR HOSE AS SHOWN.

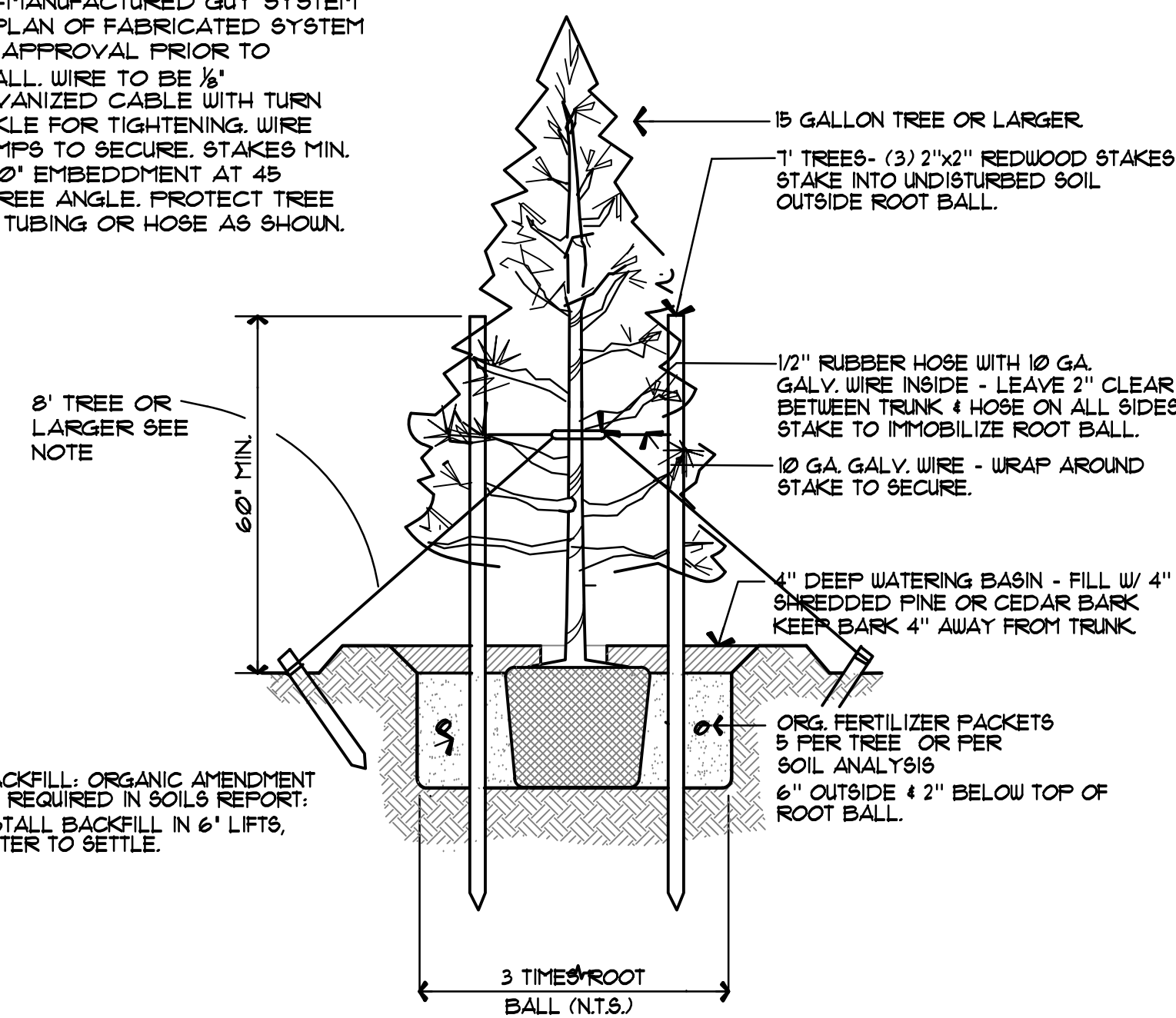

EVERGREEN TREE PLANTING

NOT TO SCALE

GENERAL LANDSCAPE NOTES:

THE CONTRACTOR SHALL COORDINATE ALL WORK WITH OTHER TRADES (IE. PAVING, PLUMBING, ELECTRICAL, ETC.)

ALL SOIL SHALL BE LOOSENED TO A DEPTH OF 8" IN ALL PLANTER AREAS PRIOR TO PLANTING. RAKE OUT ALL ROCK AND DEBRIS GREATER THAN 1 1/2" DIAMETER. ALL GRADES SHALL BE APPROVED BY THE OWNER'S REPRESENTATIVE AFTER SOIL LOOSENING, IRRIGATION MAINS AND FINAL GRADING IS COMPLETE PRIOR TO PLANTING.

SOIL IN THE PLANT BACKFILL SHALL BE AMENDED PER A SOIL ANALYSIS REPORT AND RECOMMENDATIONS PREPARED BY AN AGRICULTURAL SUITABILITY SOIL TESTING SERVICE. THE LANDSCAPE CONTRACTOR SHALL TAKE A MIN. OF 12 SAMPLES, A MIN. OF TWO FROM EACH PLANTER AREA, AFTER ALL SITE GRADING HAS OCCURRED AND PLANTERS ARE BROUGHT TO GRADE, IF REQUIRED PER CIVIL DRAWINGS. THE CONTRACTOR SHALL SUBMIT ONE COMBINED SAMPLE OF THE 12 TAKEN FOR ANALYSIS AND RECOMMENDATIONS. A COPY OF THE SOIL ANALYSIS SHALL BE SUBMITTED THE OWNER'S REPRESENTATIVE. FOR BASE BID THE CONTRACTOR SHALL ASSUME THE FOLLOWING: 6 CY. OF HUMUS PER/1000 SF AND 6 LBS. OF FERTILIZER/1000 SF. INCORPORATED INTO THE PLANT PIT EXCAVATION SOIL. FIELD SOIL AMENDMENT SHALL PER SOIL ANALYSIS REPORT AND RECOMMENDATIONS PRIOR TO BACKFILL OF PLANT PITS. SOIL AMENDMENT MAY BE MIXED PER INDIVIDUAL SOIL EXCAVATION.

THE CONTRACTOR IS RESPONSIBLE FOR PROVIDING PLANT MATERIAL PER SYMBOLS AND SPACING INDICATED ON THE PLAN. SYMBOLS PREVAIL OVER QUANTITIES LISTED IN THE PLANT LEGEND.

IT IS THE RESPONSIBILITY OF THE CONTRACTOR TO LOCATE AND PROVIDE PLANT MATERIAL AS SPECIFIED ON THIS PLAN. THE CONTRACTOR MAY SUBMIT A REQUEST TO PROVIDE SUBSTITUTIONS FOR THE SPECIFIED PLANT MATERIAL UNDER THE FOLLOWING CONDITIONS:

A. ANY SUBSTITUTIONS PROPOSED SHALL BE SUBMITTED TO THE OWNER'S REPRESENTATIVE WITHIN TWO WEEKS OF THE AWARD OF CONTRACT. SUBSTITUTIONS MUST MEET EQUIVALENT DESIGN AND FUNCTIONAL GOALS OF THE ORIGINAL PLANT MATERIAL AS DETERMINED BY THE OWNER'S REPRESENTATIVE. ANY CHANGES MUST HAVE THE APPROVAL OF THE OWNER'S REPRESENTATIVE.

B. THE REQUEST MUST BE ACCOMPANIED BY AT LEAST THREE NOTICES FROM PLANT SUPPLIERS THAT THE PLANT MATERIAL SPECIFIED IS NOT AVAILABLE PRIOR TO THE CONSTRUCTION PHASE.

ALL PLANTS NOT MEETING OR EXCEEDING REQUIREMENTS AND RECOMMENDATIONS OF ANSI 2601 'AMERICAN STANDARD FOR NURSERY STOCK' SHALL BE REJECTED. THE CONTRACTOR SHALL RECEIVE ON-SITE APPROVAL OF PLANT MATERIAL BY THE OWNER'S REPRESENTATIVE PRIOR TO PLANTING. FAILURE TO RECEIVE APPROVAL PRIOR TO PLANTING MAY RESULT IN REJECTION AND THE CONTRACTOR SHALL REPLACE ALL REJECTED PLANT MATERIAL AT HIS EXPENSE. THE OWNER RESERVES THE RIGHT TO INSPECT AND EVALUATE PLANT MATERIAL THROUGHOUT THE CONSTRUCTION AND MAINTENANCE PERIOD.

ALL PLANT SUBSTITUTIONS SHALL BE REVIEWED AND ACTION TAKEN BY THE LANDSCAPE ARCHITECT. ALL PLANT MATERIAL SHALL BE APPROVED BY THE OWNER'S REPRESENTATIVE PRIOR TO PLANTING. THE CONTRACTOR SHALL NOTIFY THE OWNER FOR PLANT REVIEW AND APPROVAL 48 HRS. PRIOR TO DELIVERY. ANY MATERIAL NOT ACCEPTABLE SHALL BE REMOVED IMMEDIATELY FROM THE SITE. THE OWNER'S

REPRESENTATIVE MAY AT ANYTIME UNTIL FINAL ACCEPTANCE DIRECT THE CONTRACTOR TO REMOVE UNACCEPTABLE MATERIAL WITHOUT COST TO THE OWNER.

THE CONTRACTOR SHALL GUARANTEE ALL PLANT MATERIALS FOR ONE FULL YEAR UPON FINAL ACCEPTANCE OF THE PROJECT. THE CONTRACTOR SHALL MAINTAIN THE SITE INCLUDING WATER SCHEDULING FOR THE ONE YEAR GUARANTEE PERIOD. ANY PLANTS REPLACED UNDER THIS GUARANTEE SHALL BE GUARANTEED FOR ONE FULL YEAR FROM THE DATE OF REPLACEMENT.

THE LANDSCAPE CONTRACTOR SHALL INSURE POSITIVE DRAINAGE IN ALL PLANTER AREAS PER CIVIL ENGINEER'S GRADING PLAN AFTER LANDSCAPE IMPROVEMENTS ARE COMPLETE.

REMOVE ALL WEEDS AND DEBRIS IN AND AROUND NEWLY INSTALLED PLANT MATERIAL. A PRE-EMERGENT HERBICIDE SHALL BE APPLIED AREAS PRIOR TO INSTALLATION OF MULCHES.

ALL DRAWINGS HEREIN ARE THE PROPERTY OF TECTONICS DESIGN GROUP AND MAY NOT BE REPRODUCED OR USED IN ANY CAPACITY WITHOUT THE WRITTEN AUTHORIZATION OF TECTONICS DESIGN GROUP.

DRAWN: KH
DESIGNED: BH
CHECKED/STAMPED: BARBARA M. HATCH RLA ASLA

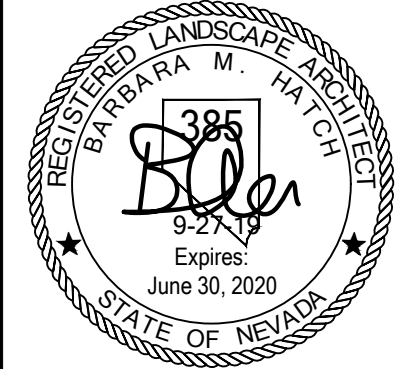

TECTONICS DESIGN GROUP
14775 Sandhill Rd., #250, Reno, Nevada, 89521
Tel: 775-824-0988
Fax: 775-824-0989
www.tectonicsdesigngroup.com

LUXELOCKER
11455 Digital Court, Spanish Springs, Nevada
Consolidated Construction Co Inc.
Appleton, WI

DATE: 6/21/19
SUBMITTAL: PERMIT SET

PROJECT/CLIENT: # 19042

LANDSCAPE PLAN

SHEET TITLE: L1.2

GreenDesign Landscape Architects, Inc.
Barbara M. Hatch ASLA
Nevada License No. 385
1464 Popinjay Drive
Reno, Nevada
89509
phone: 775.829.1364
fax: 775.829.1364
Bhatch00@charter.net

Copyright: All drawings herein are the property of Tectonics Design Group and may not be reproduced or used in any capacity without the written authorization of Tectonics Design Group.

DRAWN: KH
 DESIGNED: BH
 CHECKED/STAMPED: BARBARA M. HATCH RLA ASLA

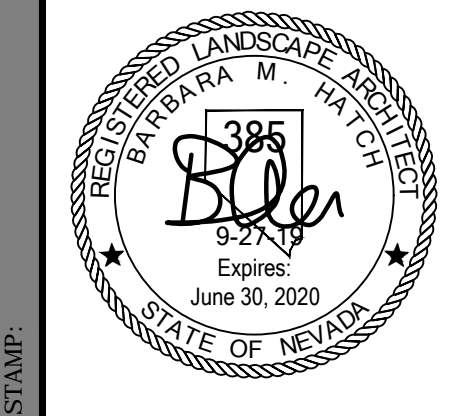

TECTONICS DESIGN GROUP
 730 Sandhill Rd., #250, Reno, Nevada 89521
 tel 775-824-9988
 fax 775-824-9986
 www.tectonicsdesigngroup.com

LUXELOCKER
 11455 Digital Court, Spanish Springs, Nevada
Consolidated Construction Co Inc.
 Appleton, WI

PROJECT/CLIENT: # 19042

DATE: 6/21/19
 SUBMITTAL RECORD: SUBMITTAL PERMIT SET

SHEET TITLE: IRRIGATION PLAN

L2.1

MAINTENANCE

THE IRRIGATION SHALL BE MAINTAINED TO ENSURE SUFFICIENT AND TIMELY WATERING NECESSARY FOR THE SURVIVAL OF ALL PLANT MATERIAL. A COPY OF THE APPROVED IRRIGATION PLAN WITH ANY AS-BUILT CONDITIONS, SHALL BE KEPT ON THE PROJECT SITE FOR REFERENCE. THE SYSTEM SHALL BE CHECKED YEARLY FOR CONTINUED OPERATION WITH THE ORIGINAL PLAN AND COMPONENTS ADJUSTED AND OR REPLACED AS REQUIRED FOR EFFICIENT OPERATION OF THE SYSTEM TO PROVIDE SUFFICIENT WATER TO ENSURE THE HEALTH OF THE PLANT MATERIAL.

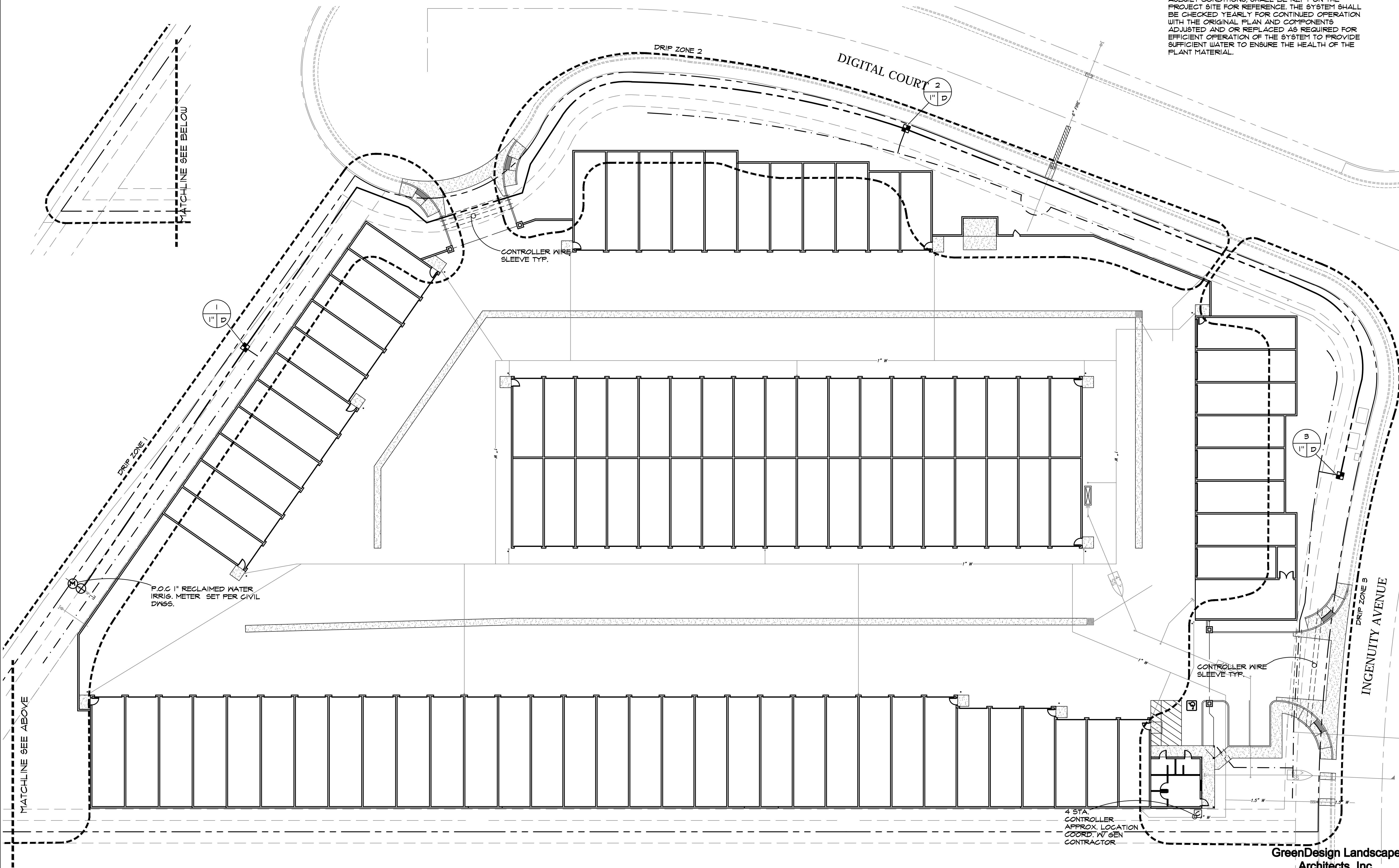

P.O.C 1" RECLAIMED WATER IRRIG. METER SET PER CIVIL DWGS.

CONTROLLER WIRE SLEEVE TYP.

4 STA. CONTROLLER APPROX. LOCATION COORD. W/ GEN CONTRACTOR

IRRIGATION PLAN
 SCALE: 1" = 20'-0"

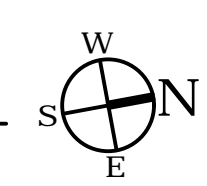

SEE SHEET L2.2 FOR IRRIGATION LEGEND

GreenDesign Landscape Architects, Inc.
 Barbara M. Hatch ASLA
 Nevada License No. 385
 1464 Popinjay Drive
 Reno, Nevada
 89509
 phone 775.829.1364
 fax 775.829.1364
 BHatch00@charter.net

IRRIGATION LEGEND:

| SYMBOL | MFG. | SERIES/MODEL | COMMENTS |
|-----------------------------------|---|--------------------------------------|--|
| | RAINBIRD | XCZ-100-COM | 1" DRIP CONTROL VALVE ASSEMBLY W/ FEB 30 PSI |
| | NIBCO | T-13-K | 1 1/4" GATE VALVE / ISOLATION VALVE |
| | RAINBIRD | E09-LXME SERIES | 6 STATION CONTROLLER |
| | LATERAL | 6CH 40 PVC (PURPLE PIPE) | INSTALL @ 18' MIN. BELOW FINISH GRADE RUN A 1" LATERAL TO ALL INDIVIDUAL PLANTER AREAS PER VALVE. |
| | IRRIG. MAIN | 1 1/4" 6CH 40 PVC (PURPLE PIPE) | INSTALL @ 24" MIN. BELOW FINISH GRADE |
| (NOT SHOWN) | RAINBIRD (OR EQUAL) | 3/4" FLEXIBLE TUBING (PURPLE STRIPE) | INSTALL @ 4" MIN. BELOW FINISH GRADE |
| (NOT SHOWN) | TORO | TURBO-SC EMITTERS | SINGLE OUTLET PRESSURE COMPENSATING - INSTALL DRIP TO ALL PLANTS @ (2) 1/2 GPH/1 GAL, 2 GPH/5 GAL, 3 GPH/15 GAL, 4 GPH/24" OR 36" BOX |
| | DRIP IRRIGATION VALVE ZONE | | |
| | SLEEVE | 4" MIN. SCH. 40 PVC (PURPLE PIPE) | 2" LARGER THAN IRRIG. PIPE (4" MIN. DIA.) INSTALL @ SPECIFIED DEPTH PER MAIN LINE OR LATERAL PIPE. EXTEND SLEEVE 12" BEYOND PAVEMENT, STAKE TO MARK FOR CONSTRUCTION ONLY. |
| P.O.C. POINT OF CONNECTION | | | |
| | VALVE IDENTIFICATION NUMBER | | |
| | GALLONS PER MINUTE OR 'D' FOR DRIP IRRIG. VALVE | | |
| | VALVE SIZE | | |
| | RAINBIRD | 33NP | 3/4" QUICK COUPLING VALVE |

RECLAIMED WATER IRRIGATION SYSTEMS

- WHEN DEEMED NECESSARY BY THE COUNTY, AN APPROVED BACKFLOW PREVENTION DEVICE SHALL BE INSTALLED, TO THE SATISFACTION OF THE COUNTY, IMMEDIATELY DOWNSTREAM OF THE METER. ALL ABOVE GROUND PIPING SHALL BE PAINTED PURPLE (PANTONE COLOR 152) AND A PURPLE TAG, WITH THE WORDING 'WARNING RECLAIMED WATER - DO NOT DRINK' IN ENGLISH AND SPANISH, ATTACHED TO THE ASSEMBLY (T. CHRISTY ENTERPRISES, VALVE IDENTIFICATION TAG, ID-5TD-P2-RCIP2 OR APPROVED EQUAL).
- ALL VALVE BOX COVERS FOR ISOLATION VALVES, ELECTRICAL CONTROL VALVES, PRESSURE REDUCING VALVES, PRESSURE REGULATING VALVES, QUICK COUPLER VALVES, AND SIMILAR AFFURTENANCES SHALL BE PURPLE IN COLOR AS SUPPLIED BY THE MANUFACTURER AND LABELED 'RECLAIMED WATER'. A PURPLE TAG, WITH THE WORDING 'WARNING RECLAIMED WATER - DO NOT DRINK', SHALL BE ATTACHED TO ALL VALVES (SEE ABOVE). ALL VALVE BOX COVERS WILL BE CAPABLE OF BEING BOLTED CLOSED, BOLTS WILL BE IN PLACE AND SECURED.
- ALL QUICK COUPLER VALVES SHALL HAVE PURPLE, LOCKABLE COVERS, I.E. RAIN BIRD 44NP OR EQUAL.
- ALL IRRIGATION CONTROLLERS SHALL BE LABELED INSIDE AND OUTSIDE WARNING THAT THE SYSTEM USES RECLAIMED WATER (T. CHRISTY ENTERPRISES, CONTROLLER MARKING DECAL, PART NUMBER #100 OR APPROVED EQUAL).
- ALL IRRIGATION MAINS, ANY LINE UPSTREAM OF AN ELECTRICAL CONTROL VALVE SHALL BE PURPLE PLASTIC, OR BE ENCASED IN PURPLE POLYETHYLENE BAGS LABELED 'CAUTION: RECLAIMED WATER LINE' AT INTERVALS NO GREATER THAN 5 FEET. IF PURPLE PIPE OR BAGS ARE NOT AVAILABLE, PURPLE VINYL ADHESIVE TAPE SHALL BE ATTACHED TO THE PIPE CONTINUOUSLY, IN A LONGITUDINAL DIRECTION. THE TAPE SHALL HAVE THE WORDING 'CAUTION: RECLAIMED WATER LINE' AT INTERVALS OF NO MORE THAN 5 FEET, HAVE A MINIMUM WIDTH OF 3", AND BE INSTALLED ALONG THE TOP OF THE PIPE.
- PURPLE, 3" WARNING TAPE, WITH WORDING 'CAUTION: RECLAIMED WATER LINE BELOW', SHALL BE INSTALLED 12 INCHES ABOVE ALL IRRIGATION MAINS.
- SIGNAGE SHALL BE POSTED, IN OBVIOUS LOCATIONS, AT THE ENTRY OF ALL PROPERTIES, LANDSCAPE ISLANDS, MEDIANS, AND OTHER USE SITES. MAXIMUM SPACING FOR ROADWAY LANDSCAPING SHALL BE DETERMINED BY THE UTILITY SERVICES DIVISION, HOWEVER, WILL IN NO CASE EXCEED 500'. SIGNS SHALL HAVE THE WORDING 'WASTEWATER EFFLUENT USED FOR IRRIGATION - DO NOT DRINK - AVOID CONTACT'. MINIMUM SIGN SIZE SHALL BE 8' X 12', LARGER SIGNS WILL BE REQUIRED AT PRIMARY ACCESS POINTS.
- RECLAIMED WATERLINES, INCLUDING IRRIGATION MAIN LINES, SHALL BE TREATED AS ON-SITE SEWER LINES AND ALL APPLICABLE SEPARATION FROM ON-SITE WATERLINES MAINTAINED.
- DIRECT CONNECTIONS BETWEEN POTABLE WATER PIPING AND RECLAIMED WATER PIPING SHALL NOT EXIST UNDER ANY CONDITION WITH OR WITHOUT BACKFLOW PROTECTION PER UPC (1994 EDITION) SECTION 6032.4.
- HOSE BIBS WILL NOT BE INSTALLED ON RECLAIMED WATER SYSTEMS.
- RECLAIMED WATERLINES, INCLUDING IRRIGATION MAIN LINES, SHALL BE TREATED AS ON-SITE SEWER LINES AND ALL APPLICABLE SEPARATION FROM ON-SITE WATERLINES MAINTAINED.
- DIRECT CONNECTIONS BETWEEN POTABLE WATER PIPING AND RECLAIMED WATER PIPING SHALL NOT EXIST UNDER ANY CONDITION WITH OR WITHOUT BACKFLOW PROTECTION PER UPC (1994 EDITION) SECTION 6032.4.
- HOSE BIBS WILL NOT BE INSTALLED ON RECLAIMED WATER SYSTEMS.

IRRIGATION NOTES

- ALL MATERIALS AND CONSTRUCTION SHALL BE IN ACCORDANCE WITH THESE PLANS, THE REQUIREMENTS OF THE CITY, THE STANDARD SPECIFICATIONS FOR PUBLIC WORKS, CONSTRUCTION, LOCAL BUILDING CODES, ORDINANCES, AND OTHER CODES OR REGULATIONS THAT APPLY.
- ALL PIPING AND WIRING UNDER PAVING SHALL BE INSTALLED IN SLEEVES. PIPING AND CONTROL WIRES UNDER PAVEMENT SHALL BE INSTALLED IN SEPARATE SLEEVES. SLEEVE SIZE SHALL BE A MINIMUM OF TWICE (2X) O.D. DIAMETER OF THE PIPE TO BE SLEEVED. CONTROLLER WIRE SLEEVES SHALL BE OF SUFFICIENT SIZE FOR THE REQUIRED NUMBER OF WIRES.
- MAINLINE SLEEVES UNDER PAVEMENT SHALL BE INSTALLED 24" BELOW TOP PAVEMENT. THE TRENCH SHALL BE CLEANED FREE OF ALL ROCK & DEBRIS, AND BACKFILLED WITH SAND TO A MINIMUM DEPTH OF 6" OVER THE SLEEVE.
- ALL MAIN LINES SHALL BE PRESSURE TESTED AT 150 PSI FOR A MINIMUM 2.5 HOUR PERIOD PRIOR TO BACKFILLING OF TRENCHES. IF ANY LEAKS ARE PRESENT THEY SHALL BE CORRECTED AND LINES SHALL BE RE-TESTED PRIOR TO BACKFILLING TRENCHES.
- PIPE SIZES SHALL CONFORM TO THOSE SHOWN ON THE DRAWINGS. NO SUBSTITUTIONS OF SMALLER PIPE SIZES SHALL BE PERMITTED, BUT SUBSTITUTIONS OF LARGER SIZES MAY BE APPROVED. ALL DAMAGED AND REJECTED PIPE SHALL BE REMOVED FROM THE SITE AT THE TIME OF SAID REJECTION.
- THE IRRIGATION CONTRACTOR SHALL FLUSH ALL LATERALS PRIOR TO INSTALLING EMITTERS.
- THIS DESIGN IS DIAGRAMMATIC. ALL PIPING, VALVES, ETC., SHOWN OUTSIDE OF THE PLANTER AREAS IS FOR DESIGN CLARIFICATION ONLY AND SHALL BE INSTALLED IN THE PLANTER AREAS.
- IT IS THE RESPONSIBILITY OF THE IRRIGATION CONTRACTOR TO FAMILIARIZE HIMSELF WITH ALL GRADE DIFFERENCES, LOCATION OF WALLS, RETAINING WALLS, STRUCTURES AND UTILITIES. THE IRRIGATION CONTRACTOR SHALL REPAIR OR REPLACE ALL ITEMS DAMAGED BY HIS WORK. HE SHALL COORDINATE HIS WORK WITH OTHER CONTRACTORS, FOR THE LOCATION AND INSTALLATION OF PIPE SLEEVES AND LATERALS UNDER ROADWAYS AND PAVING.
- SHOULD DISCREPANCIES IN THE PLANS OR FIELD MODIFICATIONS BE REQUIRED, CONTACT THE LANDSCAPE ARCHITECT PRIOR TO CONSTRUCTION FOR RESOLUTION OR CLARIFICATION.
- DO NOT WILLFULLY INSTALL THE IRRIGATION SYSTEM AS SHOWN ON THE DRAWINGS WHEN IT IS OBVIOUS IN THE FIELD THAT UNKNOWN OBSTRUCTIONS, GRADE DIFFERENCES OR DIFFERENCES IN THE AREA DIMENSIONS EXIST THAT MIGHT NOT HAVE BEEN CONSIDERED IN THE ENGINEERING. SUCH OBSTRUCTIONS OR DIFFERENCES SHOULD BE BROUGHT TO THE ATTENTION OF THE LANDSCAPE ARCHITECT. IN THE EVENT THIS NOTIFICATION IS NOT PERFORMED, THE IRRIGATION CONTRACTOR SHALL ASSUME FULL RESPONSIBILITY FOR ANY REVISIONS NECESSARY.
- ALL IRRIGATION EQUIPMENT NOT OTHERWISE DETAILED OR SPECIFIED SHALL BE INSTALLED AS PER MANUFACTURER'S RECOMMENDATIONS AND SPECIFICATIONS.
- THE CONTRACTOR SHALL AT HIS OWN EXPENSE, LOCATE ALL UNDERGROUND UTILITIES WHICH MAY AFFECT HIS OPERATION DURING CONSTRUCTION AND SHALL TAKE ALL NECESSARY PRECAUTIONS TO AVOID DAMAGE TO THE SAME.
- THE CONTRACTOR SHALL USE EXTREME CAUTION WHEN WORKING NEAR OVERHEAD OR UNDERGROUND POWER AND/OR TELEPHONE, WATER, GAS AND SEWER FACILITIES SO AS TO SAFELY PROTECT ALL UTILITIES, PERSONNEL, AND EQUIPMENT, AND SHALL BE RESPONSIBLE FOR ALL COSTS AND LIABILITY IN CONNECTION THEREWITH.
- THE CONTRACTOR SHALL TAKE ALL PRECAUTIONARY MEASURES NECESSARY TO PROTECT EXISTING IMPROVEMENTS WHICH ARE TO REMAIN IN PLACE, FROM DAMAGE, AND ALL SUCH IMPROVEMENTS DAMAGED BY THE CONTRACTOR'S OPERATIONS SHALL BE REPAIRED OR RECONSTRUCTED SATISFACTORY TO THE OWNER AT THE EXPENSE OF THE CONTRACTOR.
- AN OPEN TRENCH INSPECTION OF THE REDUCED PRESSURE PRINCIPLE BACKFLOW DEVICE SHALL BE PERFORMED BY THE WATER PURVEYOR PRIOR TO OPERATING THE IRRIGATION SYSTEM.
- THE IRRIGATION CONTROLLER SHALL BE WIRED DIRECTLY TO THE POWER SOURCE. IT SHALL BE THE RESPONSIBILITY OF THE LANDSCAPE CONTRACTOR TO BRING CONTROLLER WIRING TO THE CONTROLLER LOCATION. CONNECTING THE CONTROLLER TO THE POWER SOURCE SHALL BE THE RESPONSIBILITY OF A LICENSED ELECTRICAL CONTRACTOR. THE INSTALLATION SHALL BE IN ACCORDANCE WITH THE NATIONAL ELECTRICAL CODE AND ANY LOCAL CODES OR ORDINANCES THAT APPLY. IT SHALL BE THE ELECTRICAL CONTRACTOR'S RESPONSIBILITY TO COORDINATE THE POWER SOURCE AND EXACT LOCATION OF THE CONTROLLER WITH OWNER'S REPRESENTATIVE. FINAL CONNECTION OF THE VALVE WIRES TO THE CONTROLLER SHALL BE THE LANDSCAPE CONTRACTOR'S RESPONSIBILITY.
- INSTALL REMOTE CONTROL VALVES, PRESSURE REGULATOR AND QUICK COUPLER VALVES AS DETAILED. INSTALL R.C.V. ID TAGS MANUFACTURED BY T. CHRISTY, ENT. STANDARD SIZE, 1 1/8" HOT STAMPED BLACK LETTERS ON YELLOW BACKGROUND ON SOLENOID WIRES. LETTERS TO CONFORM TO CONTROLLER/STATION NUMBER.
- ALL VALVE CONTROL WIRE SHALL BE SIZED PER CONTROLLER AND VALVE MANUFACTURER'S RECOMMENDATIONS, BUT NOT TO BE LESS THAN NO. 14 AWG COPPER W/ APPROVED FOR DIRECT BURIAL IN GROUND. CONNECT WIRES AS DETAILED PER MANUFACTURER'S SPECIFICATIONS. RUN ONE (1) EXTRA CONTROL WIRE OF DIFFERENT COLOR THROUGH ALL VALVE LOCATIONS FROM THE CONTROLLER. EACH WIRE AT VALVES SHALL HAVE 24" EXCESS COILED LOOP IN VALVE BOXES. TAPE WIRES TO MAINLINE EVERY FIFTEEN FEET (15').
- ALL BACKFILL MATERIAL, OTHER THAN SAND AROUND THE MAINLINE, SHALL BE FREE OF ROCKS, CLODS AND OTHER EXTRANEOUS MATERIALS, COMPACT BACKFILL TO ORIGINAL DENSITY.
- AT JOB COMPLETION, SUPPLY OWNER WITH ONE (1) SET OF MATCHING QUICK COUPLER VALVE KEY AND HOSE SWIVEL, AND TWO (2) KEYS FOR THE CONTROLLER.
- RECORD ALL FIELD CHANGES FOR ASBUILT TO OWNER.
- ALL IRRIGATION INSTALLATION AND EQUIPMENT SHALL GUARANTEED FOR A PERIOD OF ONE YEAR.

IRRIGATION PLAN

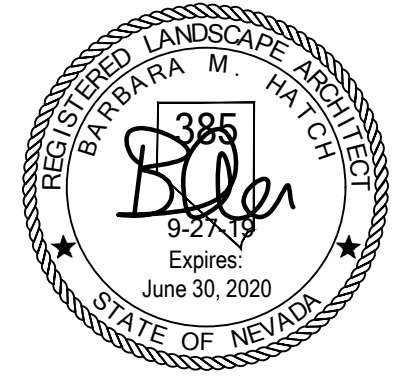

TECTONICS DESIGN GROUP
 730 Sandhill Rd., #250, Reno, Nevada 89521
 tel: 775-824-9888 fax: 775-824-9896
 www.tectonicsdesigngroup.com

LUXELCKER
 11455 Digital Court, Spanish Springs, Nevada
Consolidated Construction Co Inc.
 Appleton, WI

DATE: SUBMITTAL
 6/21/19 PERMIT SET

IRRIGATION PLAN

L2.2

All drawings herein are the property of Tectonics Design Group and may not be reproduced or used in any capacity without the written authorization of Tectonics Design Group.

DRAWN: KH
 DESIGNED: BH
 CHECKED/STAMPED:
 BARBARA M. HATCH RLA ASLA



TECTONICS DESIGN GROUP
 730 Sandhill Rd., #250, Reno, Nevada 89521
 tel 775-854-9988 fax 775-854-9986
 www.tectonicsdesigngroup.com

LUXELOCKER
 11455 Digital Court, Spanish Springs, Nevada
Consolidated Construction Co Inc.
 Appleton, WI

19042

| | |
|---------|------------|
| DATE: | SUBMITTAL |
| 6/21/19 | PERMIT SET |
| | |
| | |
| | |
| | |

LANDSCAPE & IRRIGATION DETAILS

L3.1

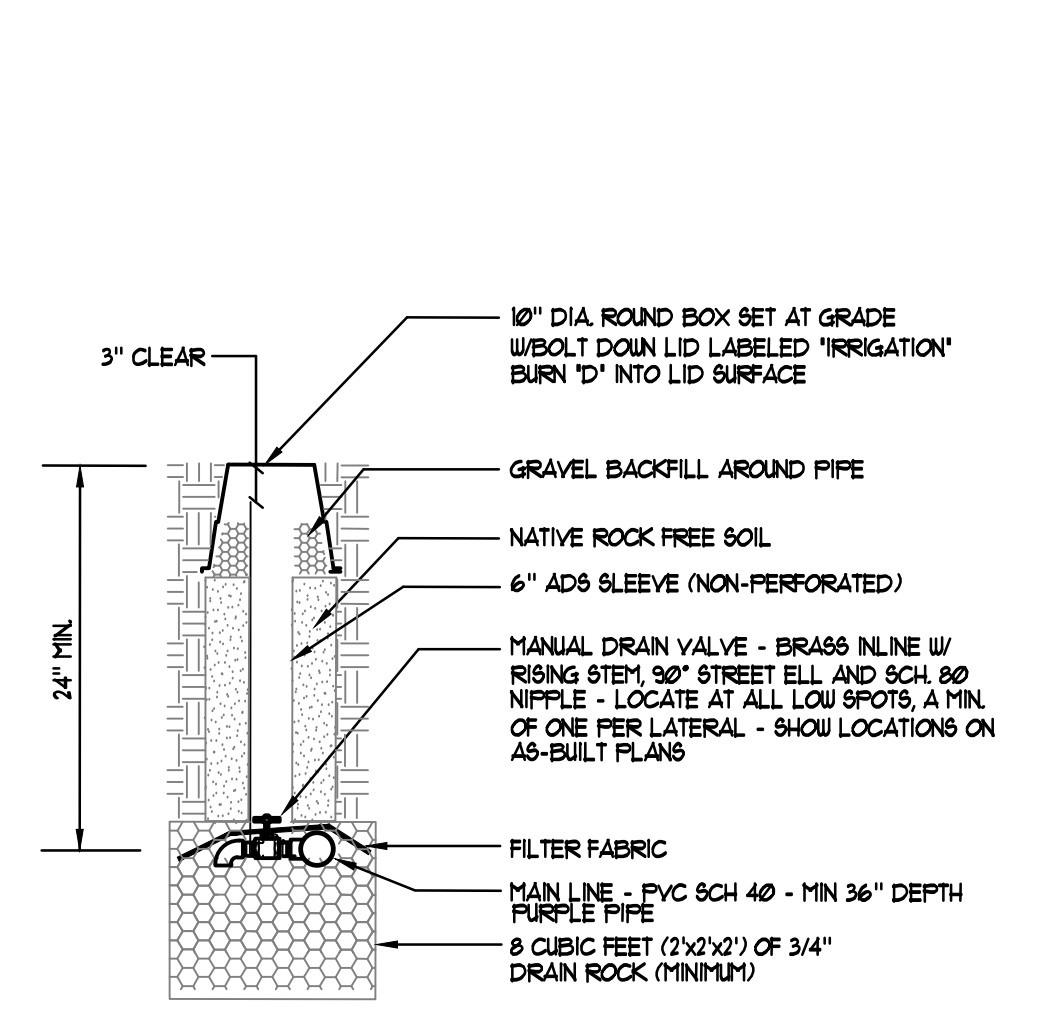

MANUAL DRAIN VALVE (LOCATE AT ALL LOW SPOTS MAINLINE)
 NOT TO SCALE

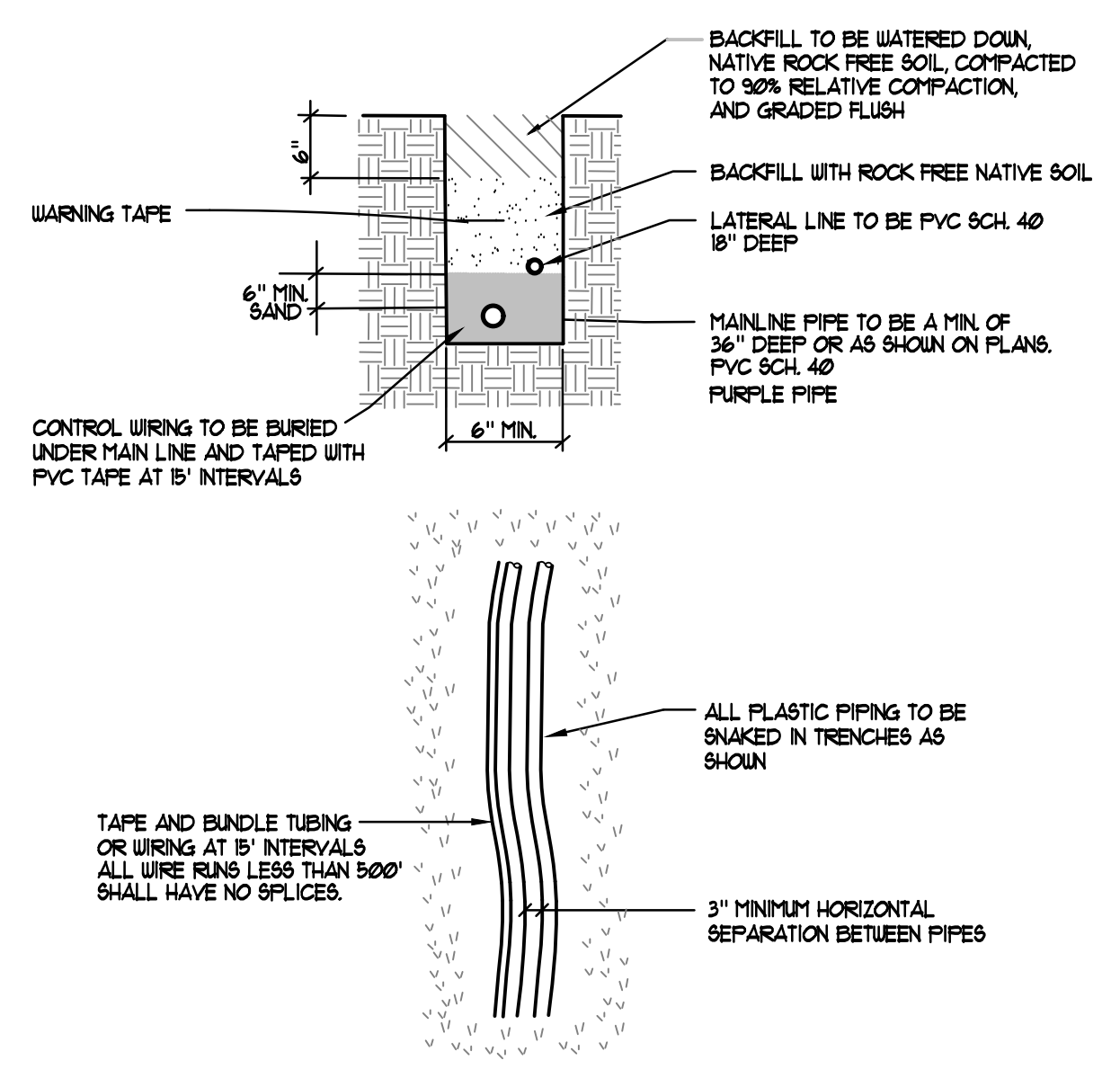

TRENCH DETAIL - LATERAL AND/OR MAINLINE (WITH WIRING)
 NOT TO SCALE

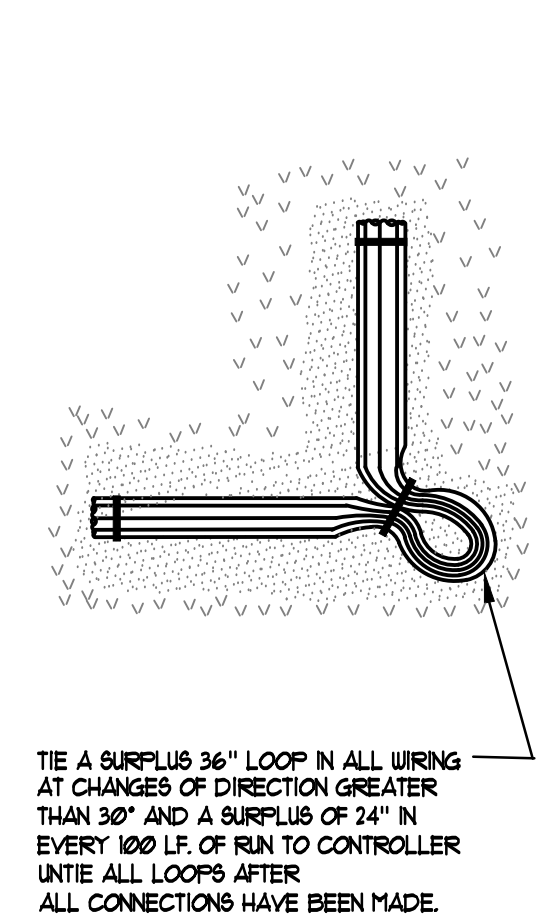

CONTROLLER WIRING
 NOT TO SCALE

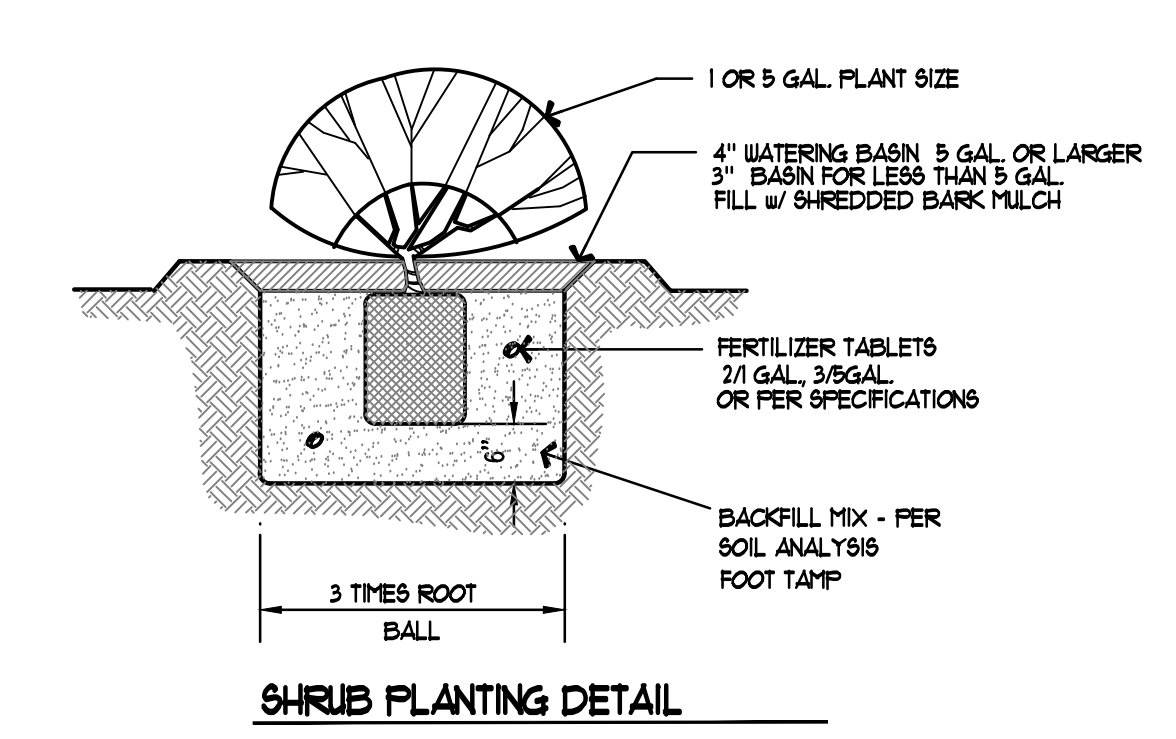

SHRUB PLANTING DETAIL

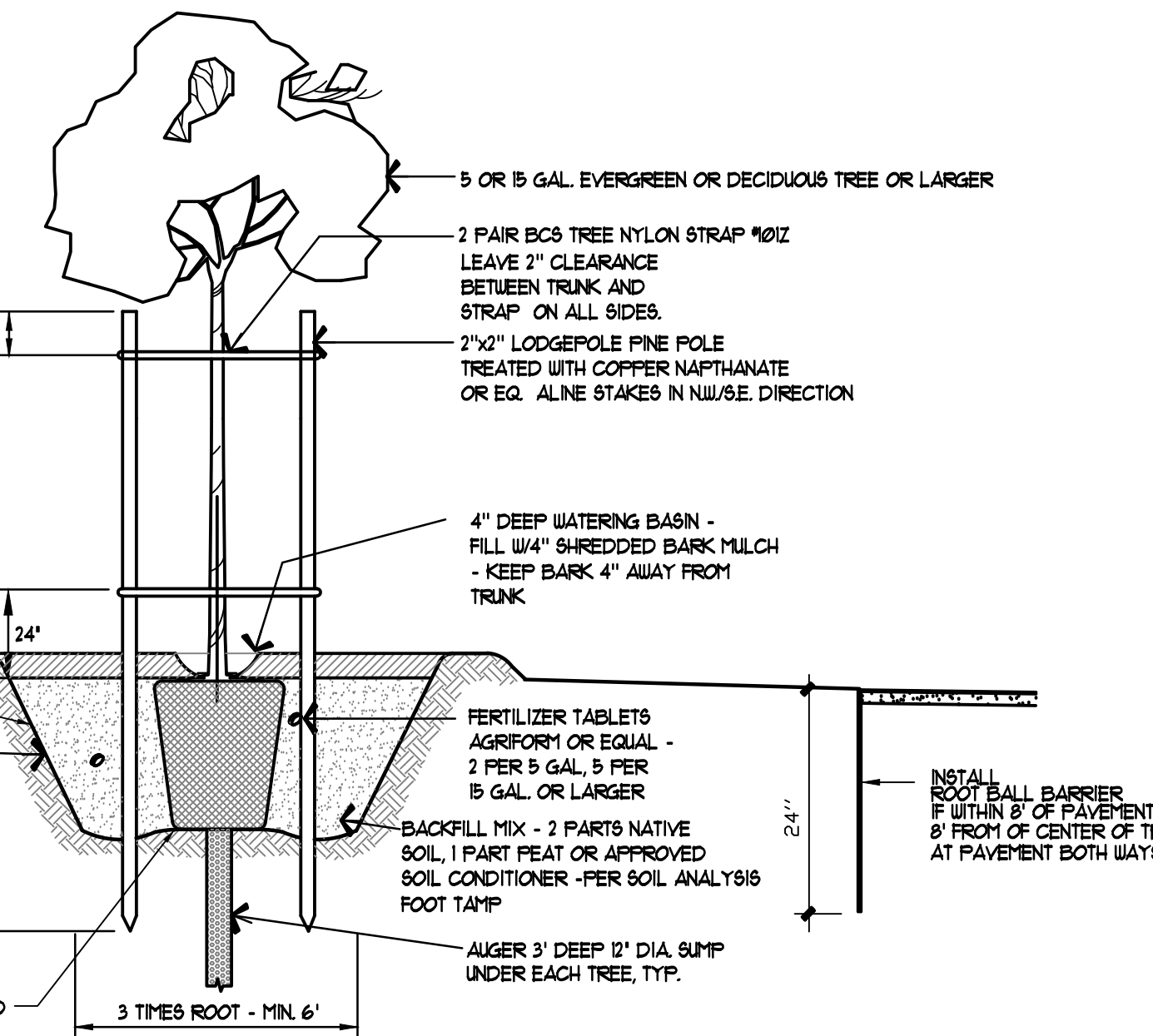

- NOTES:
- TREES SHALL BE 15 GALLON MIN, 24" MAX. SIZE.
 - ROOT CONTROL BARRIER PANELS SHALL BE REQUIRED WHERE TREE IS 8 FEET OR LESS FROM EXISTING OR FUTURE SIDEWALK OR CURB. DEEP ROOT UB-24-2 OR EQUAL MAY BE USED. LENGTH OF BARRIER = 8' CENTERED ON TREE.
 - TREES SHALL BE PROVIDED WITH AUTOMATIC IRRIGATION PER DETAIL.
 - ROOT BARRIERS SHALL NOT BE CUT.
 - NO ROCK MATERIAL LARGER THAN 1" IS ALLOWED IN BACKFILL.
 - PRESOAK HOLES FOR 24 HOURS PRIOR TO PLANTING. IF HOLE DOES NOT DRAIN CONSULT THE OWNER'S REPRESENTATIVE AND/OR LANDSCAPE ARCHITECT.

TREE PLANTING DETAIL

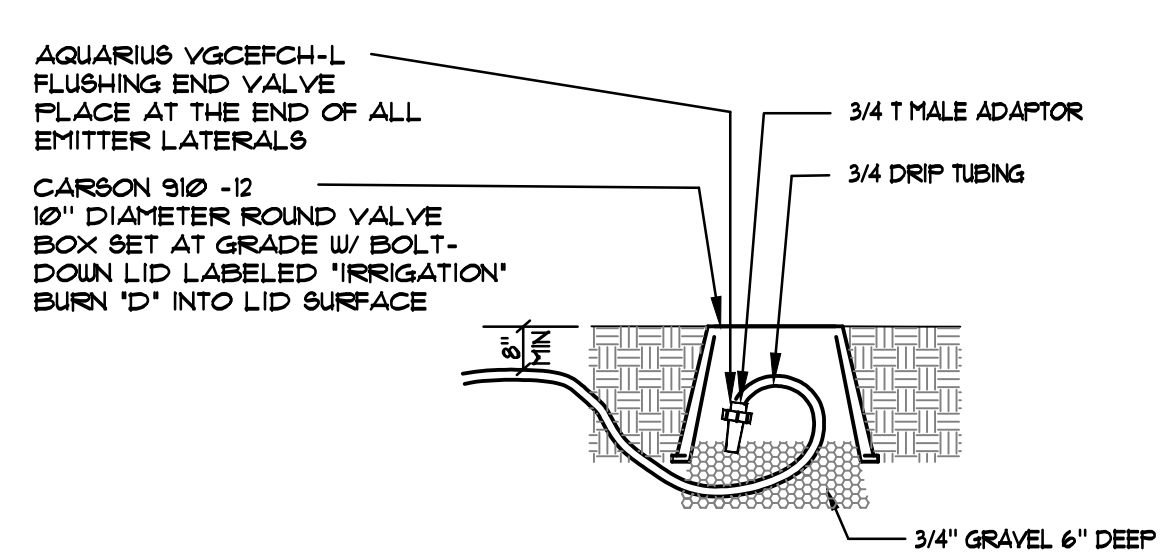

FLUSHING END PLUG
 NOT TO SCALE

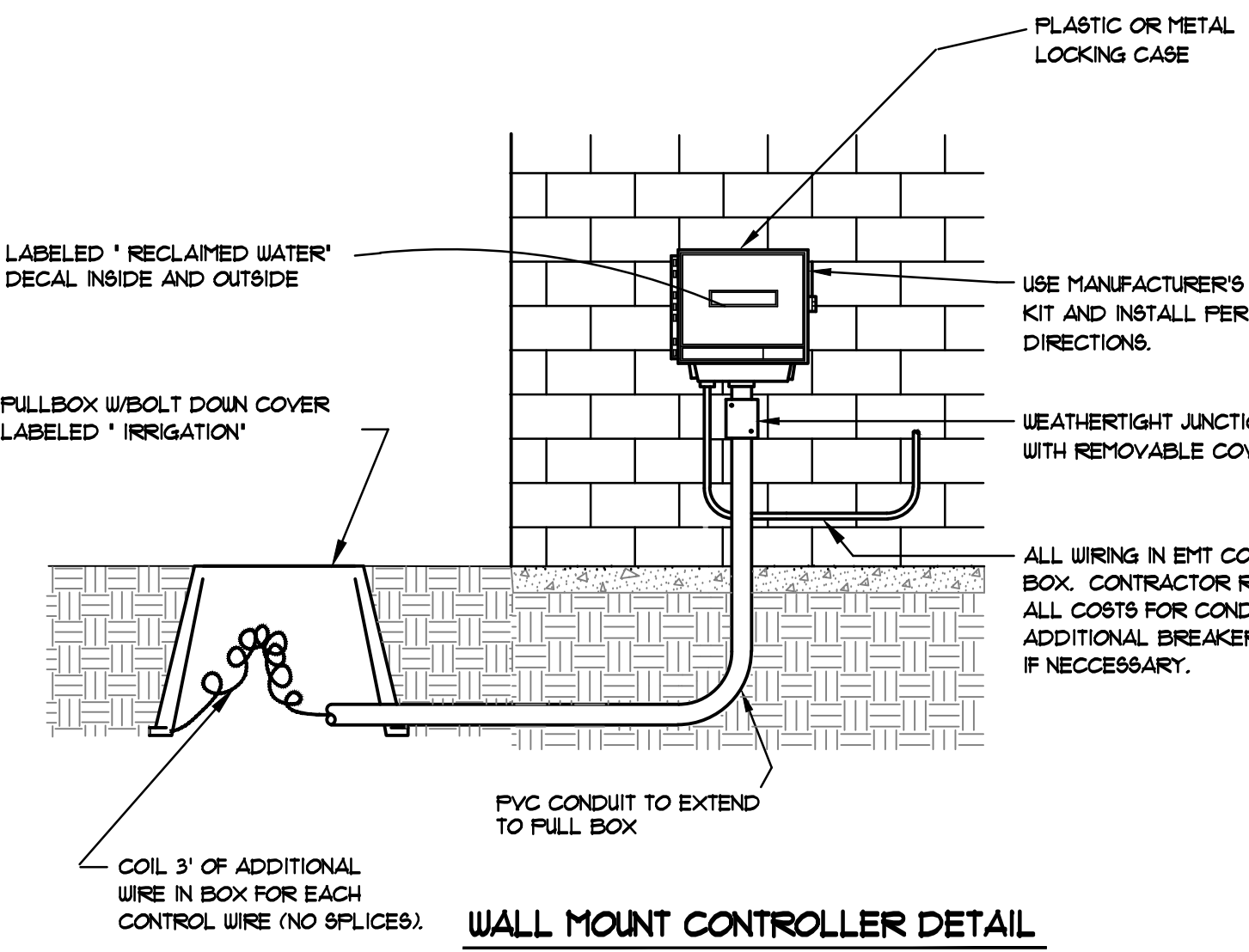

WALL MOUNT CONTROLLER DETAIL
 NOT TO SCALE

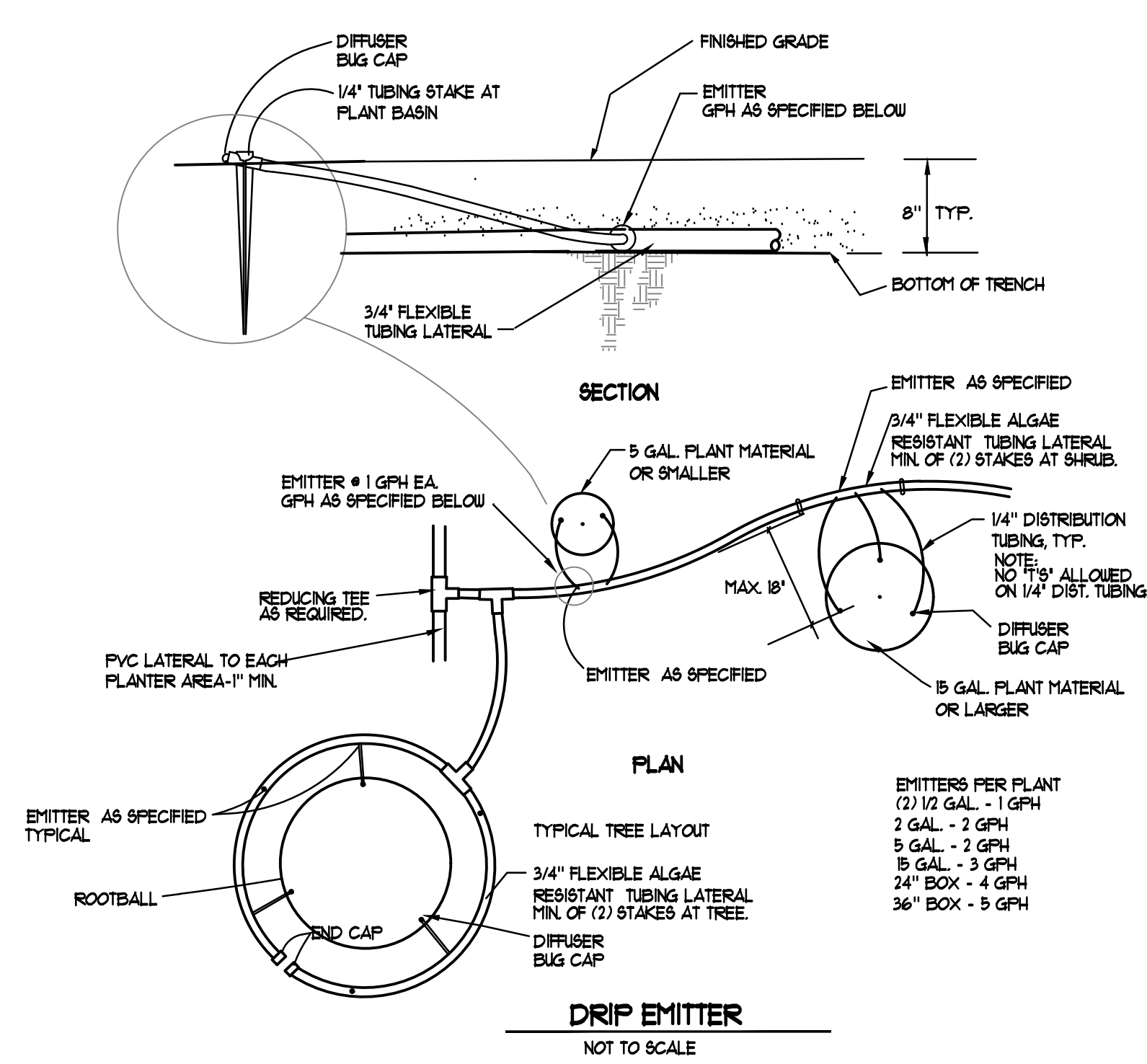

DRIP EMITTER
 NOT TO SCALE

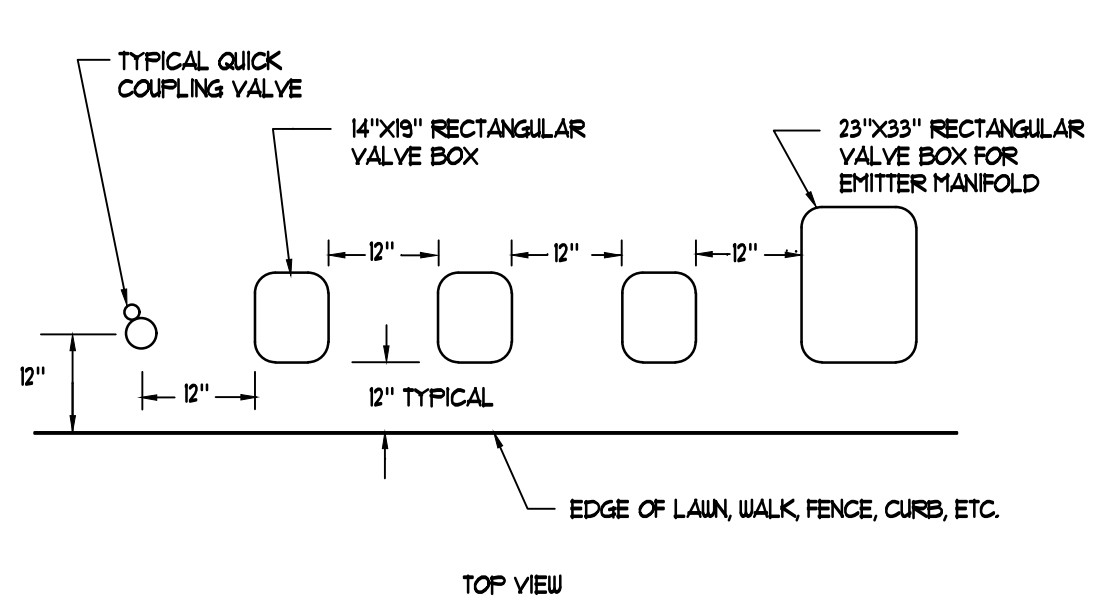

VALVE BOX
 NOT TO SCALE

- NOTES:
- CENTER VALVE BOX OVER REMOTE CONTROL VALVE TO FACILITATE SERVICING VALVE.
 - SET BOXES PARALLEL TO EACH OTHER AND PERPENDICULAR TO EDGE.
 - AVOID HEAVILY COMPACTING SOIL AROUND VALVE BOXES TO PREVENT COLLAPSE AND DEFORMATION OF VALVE BOX SIDES.
 - ALL LIDS TO BE LABELED 'RECLAIMED IRRIGATION' COLORED PURPLE.

LANDSCAPE & IRRIGATION DETAILS

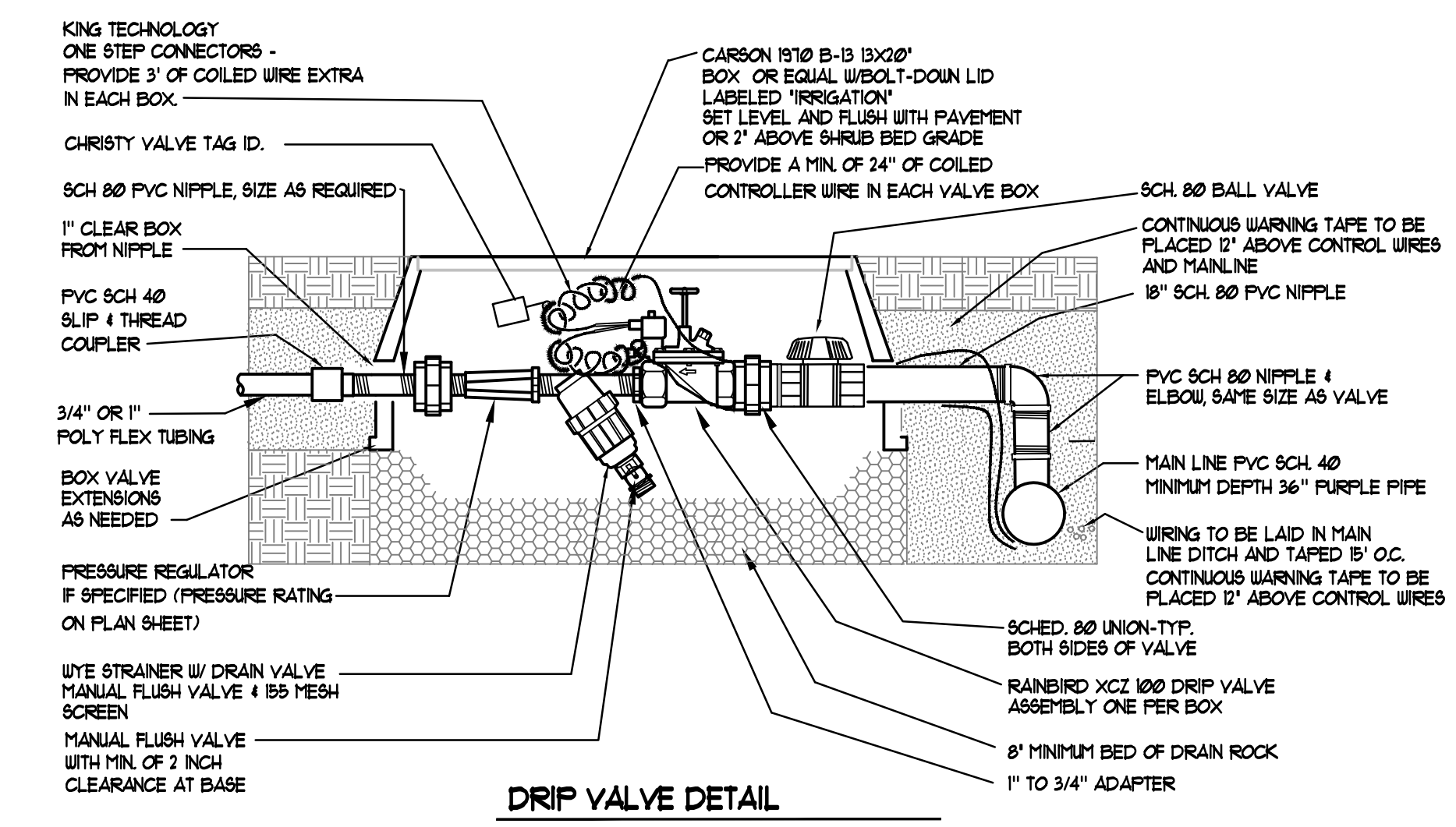

DRIP VALVE DETAIL
 NOT TO SCALE

REFER TO RECLAIMED WATER NOTES SHEET L2.2