

Washoe County Development Application

Your entire application is a public record. If you have a concern about releasing personal information, please contact Planning and Building staff at 775.328.6100.

Project Information		Staff Assigned Case No.: _____	
Project Name: Tom Cote and Tim Stevens			
Project Description: 50 Feet Wide Road Easement			
Project Address: 1453 Casey Ranch Dr. and 2305 Kelly Canyon Rd. Washoe Valley, NV			
Project Area (acres or square feet): 79,152 sq ft			
Project Location (with point of reference to major cross streets AND area locator): Kelly Canyon Rd and Winters Cr Washoe Valley, NV			
Assessor's Parcel No.(s):	Parcel Acreage:	Assessor's Parcel No.(s):	Parcel Acreage:
046-051-42	5.17 Acres		
046-051-37	4.982 Acres		
Indicate any previous Washoe County approvals associated with this application: Case No.(s). AB10-001			
Applicant Information (attach additional sheets if necessary)			
Property Owner:		Professional Consultant:	
Name: Stevens Timothy L. & Christina		Name:	
Address: 2305 Kelly Canyon Rd		Address:	
Washoe Valley, NV	Zip: 89704		Zip:
Phone: 626-222-5800	Fax:	Phone:	Fax:
Email: ttime107@me.com		Email:	
Cell: 626-222-5800	Other:	Cell:	Other:
Contact Person: Tom Cote		Contact Person:	
Applicant/Developer:		Other Persons to be Contacted:	
Name:		Name:	
Address:		Address:	
	Zip:		Zip:
Phone:	Fax:	Phone:	Fax:
Email:		Email:	
Cell:	Other:	Cell:	Other:
Contact Person:		Contact Person:	
For Office Use Only			
Date Received:	Initial:	Planning Area:	
County Commission District:		Master Plan Designation(s):	
CAB(s):		Regulatory Zoning(s):	

Abandonment Application Supplemental Information

(All required information may be separately attached)

1. What and where is the abandonment that is being requested?

A 50 ft. wide easement located at Kelly Canyon Road and Winters Creek Lane.

2. On which map or document (please include with application) is the easement or right-of-way first referenced?

Parcel map 2823

3. What is the proposed use for the vacated area?

To fully utilize the two parcels it runs through.

4. What replacement easements are proposed for any to be abandoned?

There are no replacement easements. Winters Creek Ln. is an existing road to the north that abuts the properties.

5. What factors exist or will be employed to prevent the proposed abandonment from resulting in significant damage or discrimination to other property in the vicinity?

It does not affect any other properties in the vicinity.

6. Are there any restrictive covenants, recorded conditions, or deed restrictions (CC&Rs) that apply to the area subject to the abandonment request? (If so, please attach a copy.)

* Yes * No

IMPORTANT

NOTICE REGARDING ABANDONMENTS:

To the extent that Washoe County does not own the easements in question, it cannot abandon them. Therefore, an abandonment request is in effect a "quitclaim" by the County of whatever interest it might have in the easements in favor of the owners who applied for the abandonment. For example, if the abandonment is approved by Washoe County and recorded, it will likely affect the allowable building envelope on the property, to the benefit of the applicant. However, even if the abandonment is approved, it should not be construed as an assertion by the County of ownership over the easements in question. To the extent other property owners nearby or other entities might have any ownership interests in these easements, an approved abandonment by the County does not affect those interests and the property owners associated with this abandonment are responsible for utilizing whatever legal mechanisms are necessary to address those interests on their own.



Community Development

"Dedicated to Excellence in Public Service"

Adrian P. Freund, FAICP, Community Development Director
Nathan Edwards, Legal Counsel



Washoe County Planning Commission
Dian VanderWell
Neal Cobb
Roy H. Hibdon

William Weber
Vaughn Hartung
Roger M. Edwards
D.J. Whittemore

ACTION ORDER

May 5, 2010

Tim Stevens
100 Winters Creek Lane
Washoe Valley, NV 89704

Tim Cote'
1453 Casey Ranch Road
Washoe Valley, NV 89704

Dear Applicant and Property Owner:

The Washoe County Planning Commission, at its regular meeting of May 4, 2010, approved the following request with two (2) conditions.

ABANDONMENT CASE NUMBER AB10-001 (STEVENS/COTE' RESIDENCES) – To abandon segments of Winters Creek Lane, Casey Ranch Road and associated public access as authorized in Article 806 of the Washoe County Development Code (Washoe County Code Chapter 110). The project is located at 100 Winters Creek/1453 Casey Ranch Road Lane near the Highway 395 Bowers Mansion off ramp in the West Washoe Valley. The two 5-acre parcels are designated Medium Density Rural (MDR) in the South Valleys Area Plan, and are situated in a portion of Section 27, T17N, R19E, MDM, Washoe County, Nevada. The properties are located in the West Washoe Valley Citizen Advisory Board boundary and Washoe County Commission District No. 2. (APN 046-051-42 and APN 046-051-37)

The approval was based on the following findings:

1. Comprehensive Plan. That the abandonment or vacation is consistent with the policies, action programs, standards and maps of the Comprehensive Plan and the South Valleys Area Plan;
2. No Detriment. That the abandonment or vacation does not result in a material injury to the public;
3. Existing Easements. That existing public utility easements in the area shall remain and continue to provide needed service and
4. Reasoned Consideration. That the Planning Commissioners gave reasoned consideration to the information contained within the staff report and information received during the meeting.

Letter to: Tim Stevens, Tim Cote'
Subject: Abandonment Case No. AB10-001
Date: April 7, 2010
Page: 2

If no appeals have been filed in the time period stipulated in the Washoe County Development Code, the decision by the Planning Commission is final.

Yours truly,

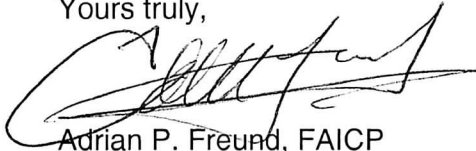

Adrian P. Freund, FAICP
Director, Washoe County Community Development
Secretary to the Planning Commission

APF/DM/ds(AB10-001A1)

Attachments: Conditions

xc: Nathan Edwards, Esq., District Attorney's Office; Carol Buonanoma, Assessor's Office (CAAS); Theresa Wilkins, Assessor's Office; Susan Hood, Department of Water Resources; Kimble Corbridge/Leo Vesely, Engineering Division; David Mills, Truckee Meadows Division, Reno Fire Department; Mike Greene, Sierra Fire Protection District

Letter to: Tim Stevens, Tim Cote'
Subject: Abandonment Case No. AB10-001
Date: April 7, 2010
Page: 3

Conditions of Approval

Abandonment Case No. AB10-001

The project approved under Abandonment Case No. AB10-001 shall be carried out in accordance with the Conditions of Approval granted by the Planning Commission on April 6, 2010. Conditions of Approval are requirements placed on a permit or development by each reviewing agency. These Conditions of Approval may require submittal of documents, applications, fees, inspections, amendments to plans, and more. These conditions do not relieve the applicant of the obligation to obtain any other approvals and licenses from relevant authorities required under any other act.

Unless otherwise specified, all conditions related to the approval of this Abandonment shall be met or financial assurance must be provided to satisfy the conditions of approval prior to issuance of a grading or building permit. The agency responsible for determining compliance with a specific condition shall determine whether the condition must be fully completed or whether the applicant shall be offered the option of providing financial assurance. All agreements, easements, or other documentation required by these conditions shall have a copy filed with the County Engineer and the Department of Community Development.

Compliance with the conditions of approval related to this Abandonment is the responsibility of the applicant, his/her successor in interest, and all owners, assignees, and occupants of the property and their successors in interest. Failure to comply with any of the conditions imposed in the approval of the Abandonment may result in the institution of revocation procedures.

Washoe County reserves the right to review and revise the conditions of approval related to this Abandonment should it be determined that a subsequent license or permit issued by Washoe County violates the intent of this approval.

For the purpose of conditions imposed by Washoe County, "may" is permissive and "shall" or "must" is mandatory.

Conditions of Approval are usually complied with at different stages of the proposed project. Those stages are typically:

- Prior to permit issuance (i.e., grading permits, building permits, etc.).
- Prior to obtaining a final inspection and/or a certificate of occupancy.
- Prior to the issuance of a business license or other permits/licenses.
- Some "Conditions of Approval" are referred to as "Operational Conditions." These conditions must be continually complied with for the life of the project or business.

The Washoe County Commission oversees many of the reviewing agencies/departments with the exception of the following agencies.

- **The DISTRICT BOARD OF HEALTH, through the Washoe County Health District, has jurisdiction over all public health matters in the Health District.**

Letter to: Tim Stevens, Tim Cote'
Subject: Abandonment Case No. AB10-001
Date: April 7, 2010
Page: 4

Any conditions set by the District Health Department must be appealed to the District Board of Health.

- **The RENO-TAHOE AIRPORT AUTHORITY is directed and governed by its own Board. Therefore, any conditions set by the Reno-Tahoe Airport Authority must be appealed to their Board of Trustees.**
- **The REGIONAL TRANSPORTATION COMMISSION (RTC) is directed and governed by its own Board. Therefore, any conditions set by the Regional Transportation Commission must be appealed to that Board.**

FOLLOWING ARE CONDITIONS OF APPROVAL REQUIRED BY THE REVIEWING AGENCIES. EACH CONDITION MUST BE MET TO THE SATISFACTION OF THE ISSUING AGENCY.

Washoe County Community Development

1. The following conditions are requirements of the Department of Community Development, which shall be responsible for determining compliance with these conditions.

Contact Name – Don Morehouse, 775.328.3632

GENERAL CONDITIONS

- a. The applicant shall demonstrate substantial conformance to the plans approved as part of this abandonment action. The County Engineer shall determine compliance with this condition.
- b. Prior to the recordation of the Order of Abandonment, the applicant shall submit to the County Engineer for review and approval a description prepared by a registered professional of the offer of dedication to be abandoned and replacement private access.
- c. The applicant shall comply with all conditions necessary to affect the Resolution and Order of Abandonment within two (2) years from the date of the action by the Washoe County Planning Commission or this conditional abandonment will be null and void.

Washoe County Department of Public Works

2. The following conditions are requirements of the Engineering Division, which shall be responsible for determining compliance with these conditions.

Contact Name – Leo Vesely, 775.325.8032

- a. Prior to recordation of the Order of Abandonment, the applicant shall submit legal descriptions to the County Engineer for review and approval. The legal

Letter to: Tim Stevens, Tim Cote'
Subject: Abandonment Case No. AB10-001
Date: April 7, 2010
Page: 5

descriptions shall be prepared by a registered professional and shall be for area of abandonment, and any easements that may be required.

- b. Retention of all public utility easements or relocation of all public utility easements to the satisfaction of and at no expense to Washoe County or the existing public utilities that originally accepted and approved said easements as well as any other public utilities now in existence that currently utilize said easements. Said relocations shall be evidenced by the recordation of properly executed documents reflecting the grant of the new easements (if required) to said public utilities and the relinquishment by said public utilities of their former easements.
- c. Retention of all drainage easements or relocation of all drainage easements to the satisfaction of and at no expense to Washoe County as well as any drainage facilities now in existence that currently utilize said easements. Said relocations shall be evidenced by the recordation of properly executed documents reflecting the grant of the new easements (if required).
- d. A reciprocal access and emergency access easement shall be granted for either a circular turnaround (50' radius) or a 'Hammer Head" turnaround located on the common parcel line of parcels 046-051-37 and 046-051-42 adjacent to the north parcel lines of 046-051-38 and 046-051-43. Sierra Fire Protection District and the County Engineer shall determine compliance with this condition.
- e. The applicant shall comply with conditions necessary to effect the Resolution and Order of Abandonment within two (2) years from the date of the action by the Planning Commission or this conditional abandonment will be null and void.

***** End of Conditions *****

ROADWAY ABANDONMENT

LYING WITHIN A PORTION OF SECTIONS 26 & 27
TOWNSHIP 17 NORTH, RANGE 19 EAST, M.D.M.
WASHOE COUNTY, NEVADA

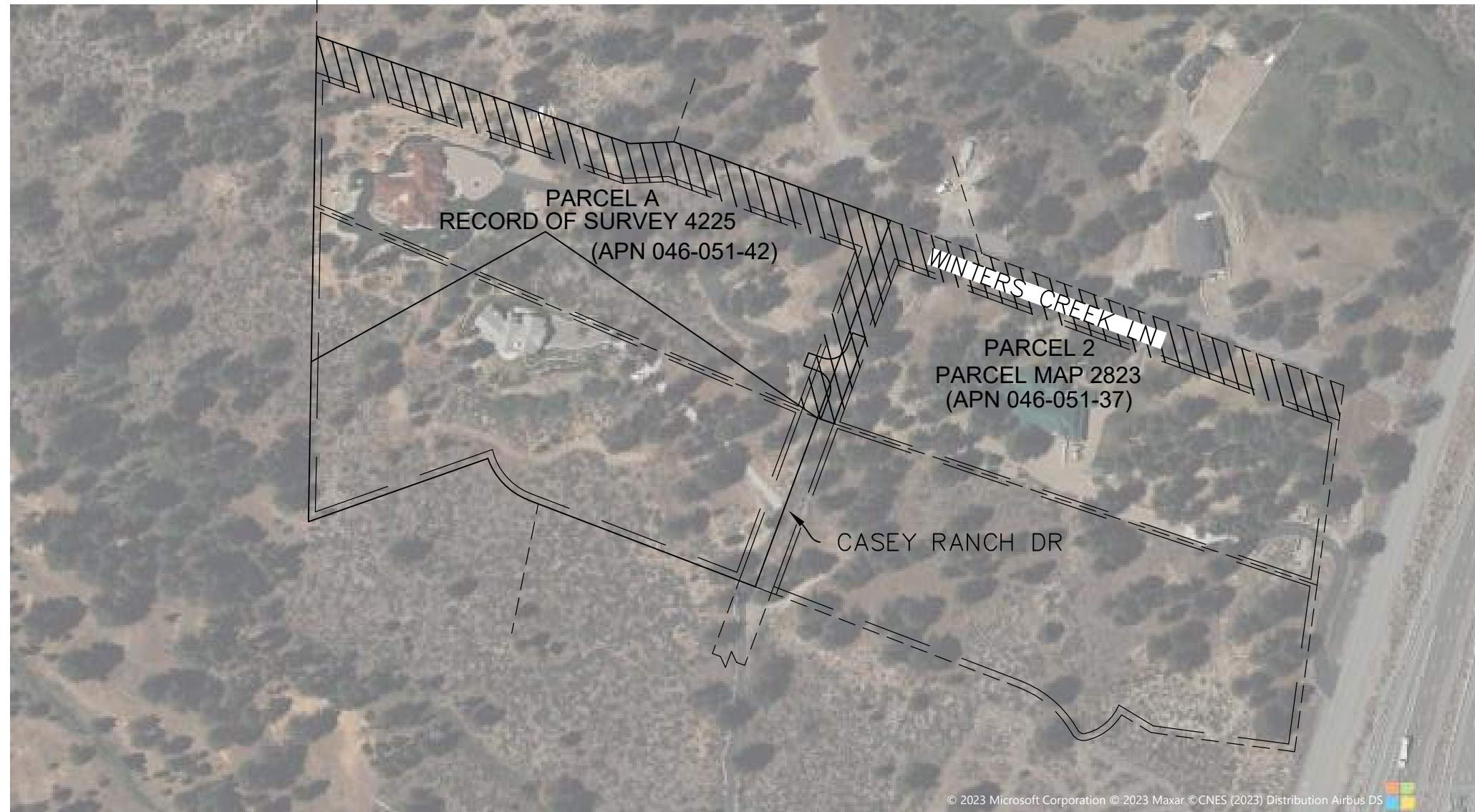

AREA OF ABANDONMENT



FILE: COTE_ABNDNMNT_2023.dwg
JUB PROJ. #: 49-23-039
DATE: 11/27/2023
SHEET # 1

ROADWAY ABANDONMENT
THOMAS J. COTE & TIMOTHY L. STEVENS

JUB
J-U-B ENGINEERS, INC.
9160 DOUBLE DIAMOND PKWY.
RENO, NEVADA 89521
(775) 852-1440 MAIN

EXHIBIT "___"
LEGAL DESCRIPTION
AREA OF ABANDONMENT

All that certain real property lying within a portion of the northeast quarter (NE1/4) of Section twenty-seven (27) and the northwest quarter (NW1/4) of Section twenty-six (26), Township seventeen (17) North, Range nineteen (19) East, Mount Diablo Meridian (MDM), County of Washoe, State of Nevada, further described as follows:

BEING that portion of Casey Ranch Road, together with that portion of Winters Creek Lane, lying within Parcel 2, as shown on Parcel Map 2823 filed as document number 1829982 on September 2, 1994 and Parcel A as shown on Record of Survey 4225 filed as document number 2828951 on March 31, 2003.

EXCEPTING THEREFROM: Any public utility easement for any existing utilities within the described area.

Containing 106,849 square feet of land, more or less;

Prepared by:

J-U-B Engineers, Inc.

5190 Neil Road, Suite 500

Reno, Nevada 89502

775-745-2176

Jon Loder, P.L.S.

Nevada Certificate No. 10842

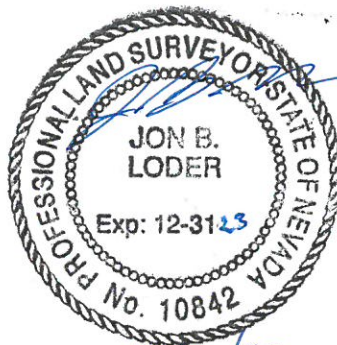

12/08/23

ROADWAY ABANDONMENT

LYING WITHIN A PORTION OF SECTIONS 26 & 27
TOWNSHIP 17 NORTH, RANGE 19 EAST, M.D.M.
WASHOE COUNTY, NEVADA



1"=50'
DETAIL:
EMERGENCY TURNAROUND
EASEMENT

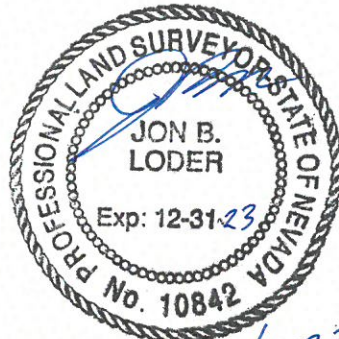
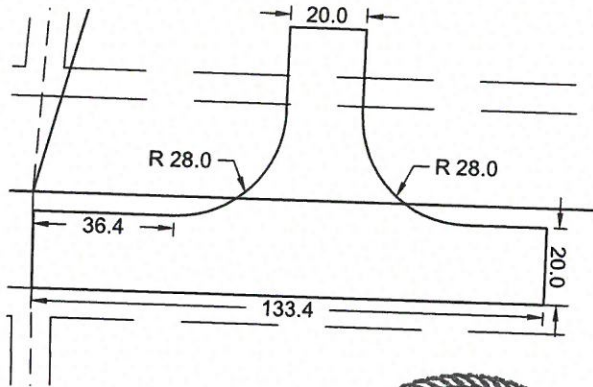

12/08/2023

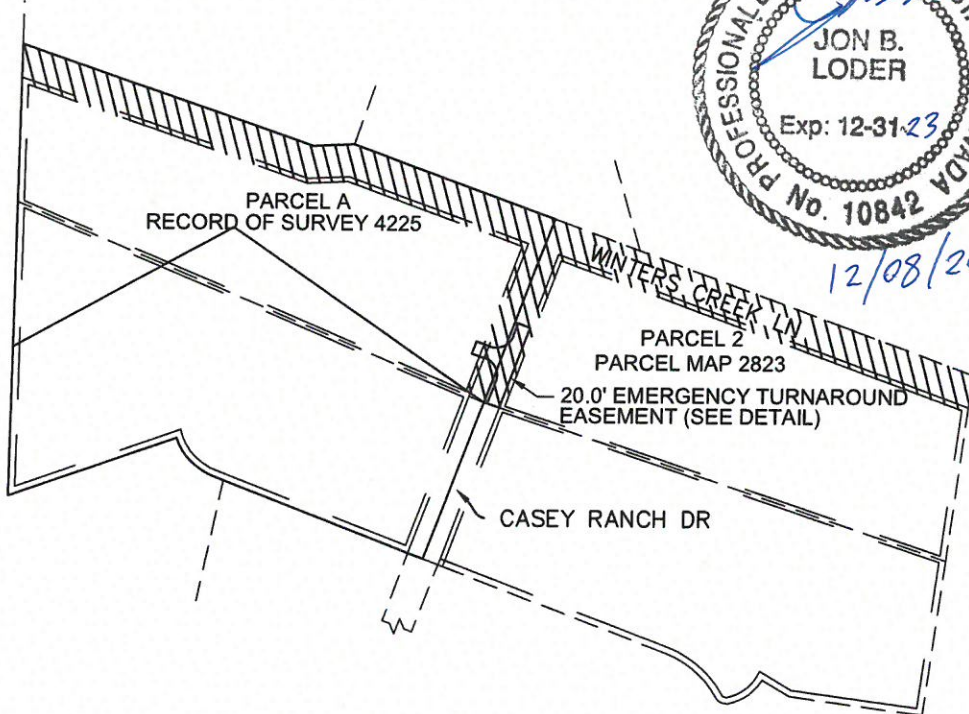

AREA OF ABANDONMENT



1"=300'

FILE: COTE_ABNDNMNT_2023.dwg

JUB PROJ. #: 49-23-039

DATE: 11/27/2023

SHEET # 1

ROADWAY ABANDONMENT
THOMAS J. COTE & TIMOTHY L. STEVENS



J-U-B ENGINEERS, INC.
9160 DOUBLE DIAMOND PKWY.
RENO, NEVADA 89521
(775) 852-1440 MAIN