

1 1/2" WIDE BY 3/8" THICK STEEL STRAP (SEE CHART FOR LENGTH). ANCHOR STEEL STRAP TO SIGN AND POST WITH THREE (3) 3/8" DIAMETER GRADE 5 BOLTS PER TYPICAL BOLT DETAIL \*

L1	W1
30"	43"
36"	51"
42"	60"

\* STEEL STRAP REQUIRED ON ALL SQUARE, RECTANGULAR OR TRIANGULAR WHEN "L1" IS 30" OR GREATER

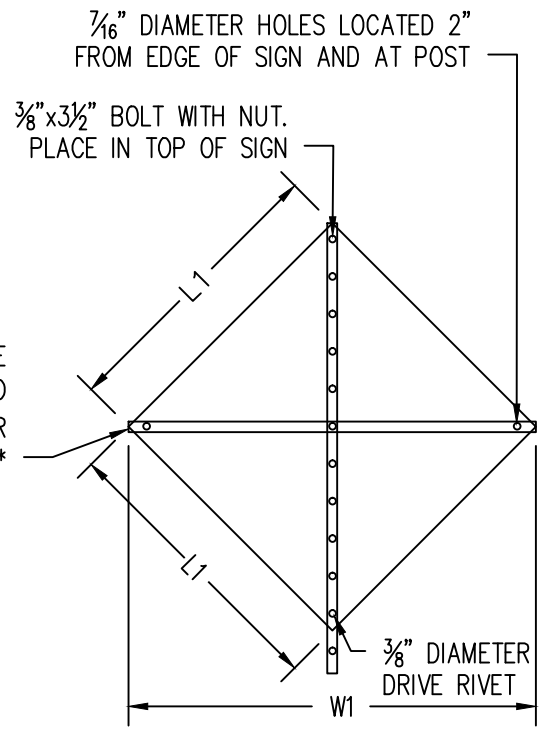

DATE	REVISIONS



STANDARD DETAILS FOR PUBLIC WORKS CONSTRUCTION

## STANDARD TRAFFIC SIGN DETAIL

SECTION NUMBER: <b>400</b>
DRAWING NUMBER: <b>W-402B</b>
DATE: <b>2/21/2022</b>