

SECTION A-A'  
N.T.S.

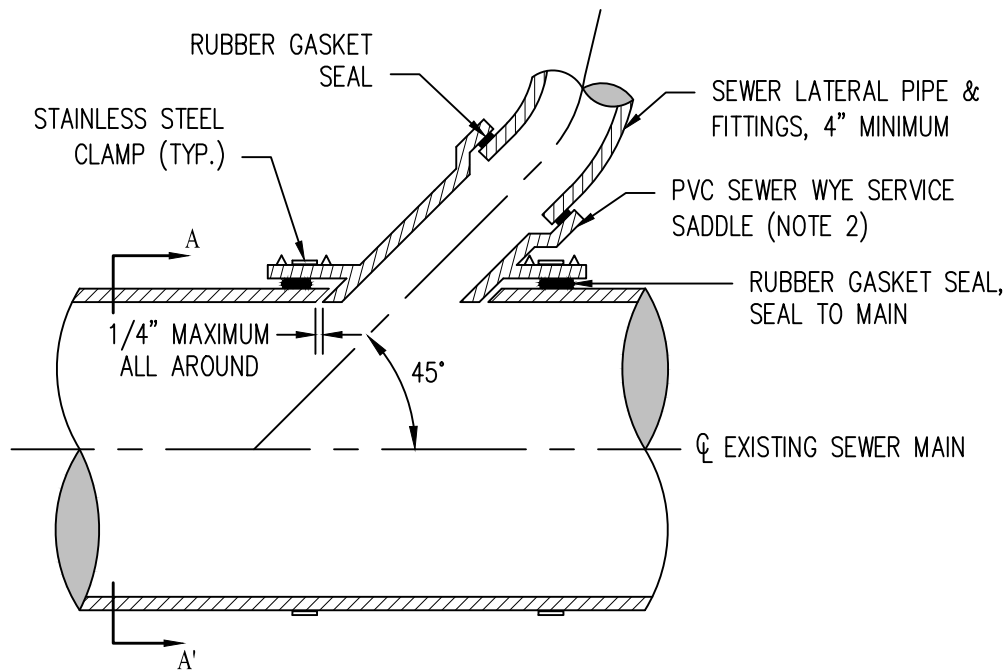

SIDE VIEW

**NOTES:**

1. EXISTING SEWER MAINS SHALL BE CORE DRILLED UTILIZING A DRILL GUIDE FOR A WYE SADDLE AND A CORE DRILL WITH A LENGTH EXCEEDING THE LATERAL DIAMETER, INSERT-A-DRILL IDY75 & EXTRA LONG HOLE SAW OR APPROVED EQUAL. DIAMOND CORE BITS SHALL BE USED ON NON-PVC MAINS.
2. SERVICE TAP SADDLES SHALL BE PVC SEWER WYE SADDLES. A ROMAC STYLE "CB" SEWER SADDLE OR APPROVED EQUAL MAY BE USED ON EXISTING SEWER MAINS ONLY WHEN MAIN IS NOT PVC.
3. SADDLES SHALL BE INSTALLED AT 45 DEGREES TO MAIN AS SHOWN IN SECTION A-A'. IN NO CASE SHALL A LATERAL CONNECTING TO THE EXISTING SEWER MAIN BE LOCATED DIRECTLY ON TOP OF THE PIPE, NOR SHALL IT MATCH THE FLOWLINE OF THE PIPE.

DATE	REVISIONS



STANDARD DETAILS FOR PUBLIC WORKS CONSTRUCTION

SANITARY SEWER  
TAP SADDLE

SECTION NUMBER: <b>200</b>
DRAWING NUMBER: <b>W-231</b>
DATE: <b>2/21/2022</b>