



Sanitary Sewer and Storm Drain Acceptance Requirements

It is the intent of these specifications to set forth the Washoe County requirements for acceptance of public sanitary sewer and storm drain. Public improvements are those that are or may become dedicated, owned, or maintained by Washoe County. Work and products shall be in accordance with Washoe County Development Code, the provisions of the Standard Specifications for Public Works Construction (SSPWC) adopted by Washoe County, in effect at that time, Washoe County Standard Details, Occupational Safety and Health Administration regulations, and other ordinances that may apply. The General Contractor shall furnish all labor, materials, equipment, and retention services for the testing and inspection requirements described herein.

1. Protection of Existing Sanitary Sewer and Storm Drain Utilities

- 1.1 The contractor must control and prevent debris from entering and collecting in the existing Sanitary Sewer and Storm Drain System.
- 1.2 The contractor shall use a Debris Trap at the first Sanitary Sewer and/ or Storm Drain manhole where the new utilities will connect to the existing utilities.
- 1.3 The Debris trap shall be procured and installed by the contractor, with type and installation approved by Washoe County. An acceptable Debris Trap example is located on Exhibit A at the end of these requirements.
- 1.4 The Debris Trap shall be protected from removal and periodically inspected throughout the project duration by the contractor. Debris to be removed from manhole periodically and prior to trap removal.
- 1.5 The Debris Trap shall remain in place for duration of project, The trap can only be removed once manhole is clean and the new Utilities are accepted by Washoe County.

2. Manhole Vacuum Test - Sanitary Sewer

- 1.1 Manhole vacuum testing shall be conducted by the General Contractor in the presence of the County Engineer or his representative, with a minimum of 48 hours advance notice of the testing.
- 1.2 Each manhole shall be tested after assembly and prior to densified soil backfill.
- 1.3 All lift holes shall be permanently filled with an approved non-shrink grout.
- 1.4 All pipes entering the manhole shall be temporarily and securely plugged. The test head shall be placed at the top of the cone section and the seal inflated according to the manufacturer's recommendations. A vacuum of 10-inches of mercury shall be drawn and the vacuum pump shut off. With the valves closed, the time shall be measured for the vacuum to drop 1-inch. The manhole shall pass if the time is greater than 60 seconds for 48-inch diameter, 75 seconds for 60-inch diameter and 90 seconds for 72-inch diameter manholes. If the time lapse is less than



described above, the General Contractor shall make the necessary repairs prior to performing the retest. Retesting shall continue until a satisfactory test is observed by Washoe County.

3. Air Pressure Test - Sanitary Sewer

- 2.1 Air pressure testing of the sewer pipeline and branching connection sewer laterals shall be conducted by the General Contractor in the presence of the County Engineer or his representative, with a minimum of 48 hours advance notice of the testing.
- 2.2 All sewer laterals entering the pipeline shall be temporarily and securely plugged.
- 2.3 Air shall be introduced into the pipeline until 3.0-psi gauge pressure has been reached. After the temperature has stabilized and no leaks at the plugs have been found, the air pressure shall be permitted to drop and when the internal pressure has reached 2.5-psi gauge pressure, the line shall be disconnected from the air source and a stopwatch shall be used to determine the time lapse required for the air pressure to drop to 1.5-psi gauge pressure.
- 2.4 If the time-lapse, in seconds, required for the air pressure to decrease from 2.5-psi to 1.5-psi gauge pressure exceeds the acceptable limits, described in the SSPWC, the pipe shall be presumed to be within the acceptable limits for leakage.
- 2.5 If the time lapse is less than the acceptable limits described in the SSPWC, the General Contractor shall make the necessary corrections to reduce the leakage to acceptable limits.

4. Deflection Test - Sanitary Sewer

- 3.1 Deflection testing shall be conducted by the General Contractor in the presence of the County Engineer or his representative, with a minimum of 48 hours advance notice of the testing.
- 3.2 The pipe will be observed for evidence of deflection, offset joints, and other pipe defects.
- 3.2 Deflection tests shall be performed no sooner than 30 days after completion of placement and densification of backfill.
- 3.4 The nonadjustable mandrel shall be constructed of steel or aluminum that can withstand 200-psi without being deformed. The mandrel shall have an odd number of arms, with a minimum of nine arms. The mandrel shall have an outside diameter (OD) equal to 95-percent of the inside diameter (ID) of the pipe. The barrel section of the mandrel shall have a length of at least 75percent of the ID of the pipe. The Contractor shall provide a proving ring for each size mandrel in use. The maximum base ID shall be equal to the average OD minus two times the minimum wall thicknesses, in accordance with SSPWC and other manufacturing tolerances, for determining maximum allowable deflections.
- 3.5 The mandrel shall be pulled through the pipe by hand to ensure that maximum allowable deflections have not been exceeded.



3.6 If the mandrel fails to pass, the pipe will be deemed to be overly deflected. Any overly deflected pipe shall be removed and replaced by the General Contractor. It shall be the General Contractor's responsibility to locate and retrieve any lost or broken mandrels or other equipment left in the pipe during the testing process. Any damage resulting or repairs required from lost or broken equipment shall be at the General Contractor's expense. Closed circuit television inspection will not be a substitute for deflection testing.

5. Closed Circuit Television (CCTV) Inspection - Sanitary Sewer and Storm Drain

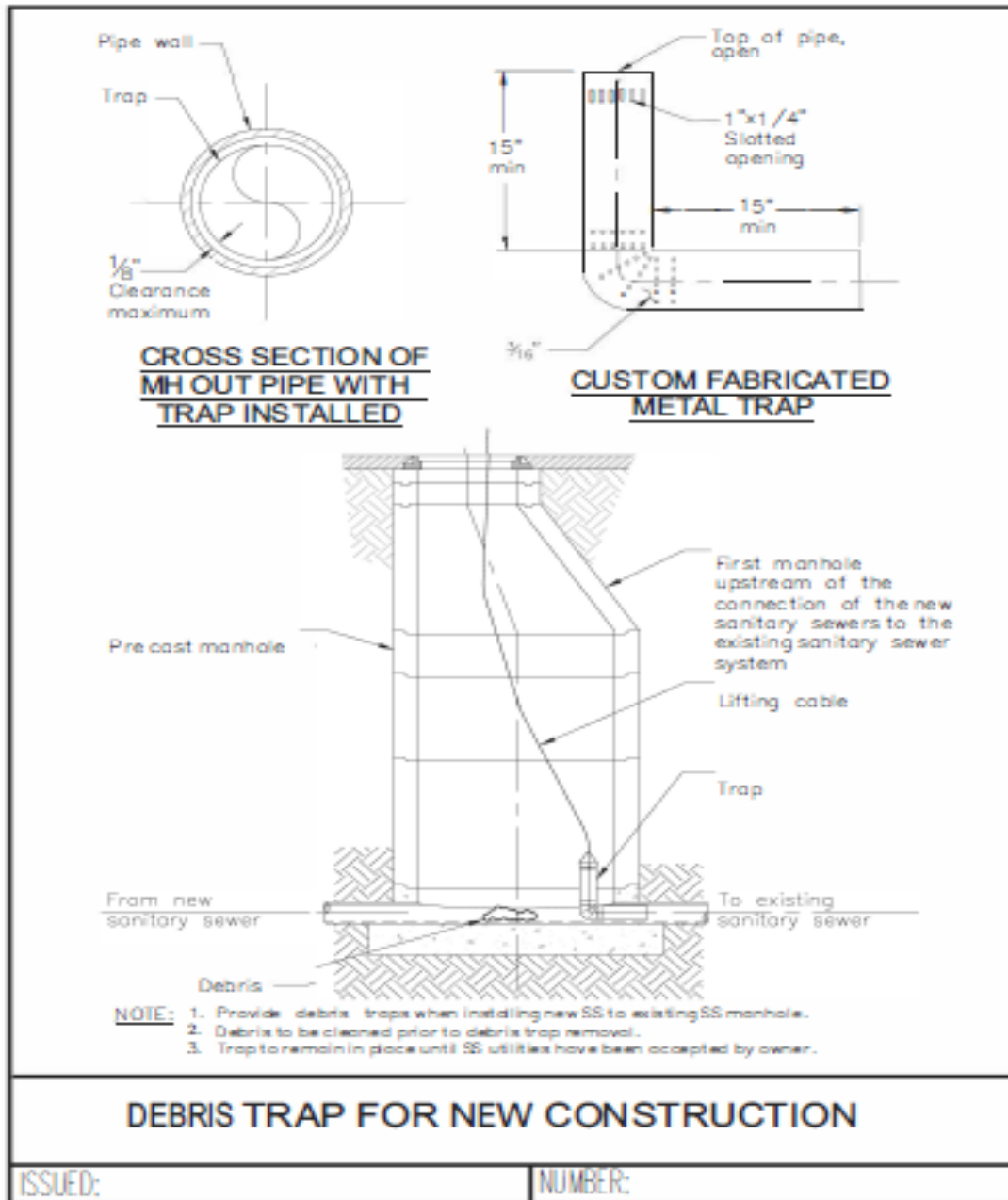
- 4.1 The interior of all sanitary sewers shall be CCTV inspected. The interior of storm drain pipes shall be CCTV inspected as requested by the County Engineer or his representative, with a minimum of 48 hours advance notice of the CCTV inspection.
- 4.2 The General Contractor shall be responsible for retaining the services of an independent CCTV Contractor to conduct the CCTV inspection. The Contractor performing CCTV inspection shall use the most current National Association of Sewer Services Companies (NASSCO) standards.
- 4.3 All CCTV inspections of sanitary sewer and storm drain shall be reviewed and accepted by Washoe County after all underground utilities are installed and prior to paving. The CCTV inspection shall be conducted after successfully passing a deflection test and air pressure test. All pipes and manhole structures shall be cleaned of debris. All pipes shall be cleaned by the Contractor at least 24 hours prior to CCTV inspection.
- 4.4 The CCTV Contractor shall provide onscreen written and voiceover narration of the inspection, the street location, upstream and downstream manhole control points from the Improvement Plans, date, and time of the CCTV inspection. If Washoe County determines that the CCTV video is defective or not of adequate quality, the CCTV Contractor shall conduct subsequent CCTV inspections at the CCTV Contractor's expense.
- 4.5 Each color CCTV camera shall be intrinsically safe and shall function in 100-percent humidity conditions. Lighting intensity shall be remote controlled and shall be adjusted to minimize reflective glare. Lighting and camera quality shall provide a clear, focused picture of the entire 360-degree periphery view inside of the sewer or storm drain. The camera shall have an articulated head and be adjustable for height in order to have the camera centered in the pipe being inspected. The camera shall have the capability of taking still, color photos. The camera shall have pan and tilt capabilities. A footage counter device, which measures the distance traveled by the camera in the pipe, shall be accurate to plus or minus 0.5-feet in 1,000-feet. This counter shall be displayed on the recorded image at all times while inspecting the pipe. The equipment shall include genlocking capabilities to the extent that computer-generated data, (footage, date, size, address and location, etc.) can be overlaid onto the image, and both indicated on the television monitor and permanently recorded on the inspection video. The camera shall have the capability to indicate the depth of water in pipe sags.

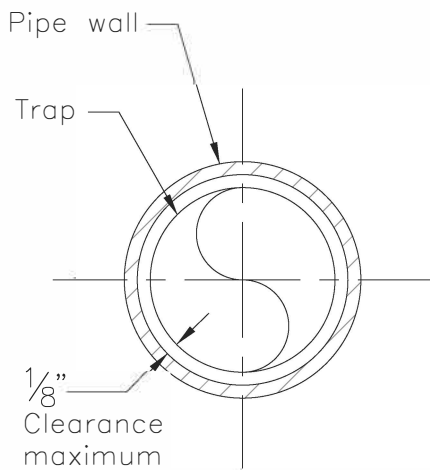


- 4.6 The inspection video shall be in digital MPEG format with audio location and date information, inspection title information that includes both hard copy and digital inspection logs. Video header information and inspection logs for the pipe shall include, at a minimum, pipe identification as shown on the Improvement Plans. The digital inspection logs shall be submitted in PDF format. All digital files shall be delivered to Washoe County on a DVD or USB Flash Drive. There shall be a separate MPEG file for each run of pipe, from manhole to manhole, and each file shall be able to be viewed with Microsoft Windows Media Player.
- 4.7 Each CCTV inspection shall be performed using a small stream of clean water and begin with the camera looking up at the manhole lid and end at the very next manhole, looking up at the manhole lid. The CCTV Contractor shall be responsible to locate and retrieve any lost or broken CCTV equipment left in the pipe at their expense. No spliced videos will be allowed for any single pipe sections. The video must be obtained during one continuous pass beginning at a manhole and ending at a manhole. The camera image shall be down the center axis of the pipe when the camera is in motion. Points of interest shall also be recorded, inspected and shall include, but not be limited to, lateral connections and defects in the pipe, including but not limited to, sags greater than 5-percent of the ID of the pipe, offset joints, debris or obstructions, cracked or damaged pipe, torn or rolled gaskets, and infiltration.
- 4.8 The General Contractor shall be responsible for any ensuing work required to remedy any defects that are identified by Washoe County on the CCTV inspections prior to project completion. All repairs shall have subsequent CCTV inspections after the actual repair and backfill is complete.

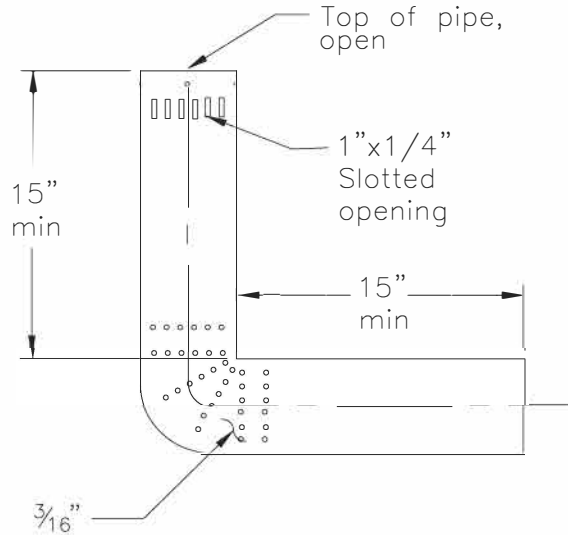


Exhibit A

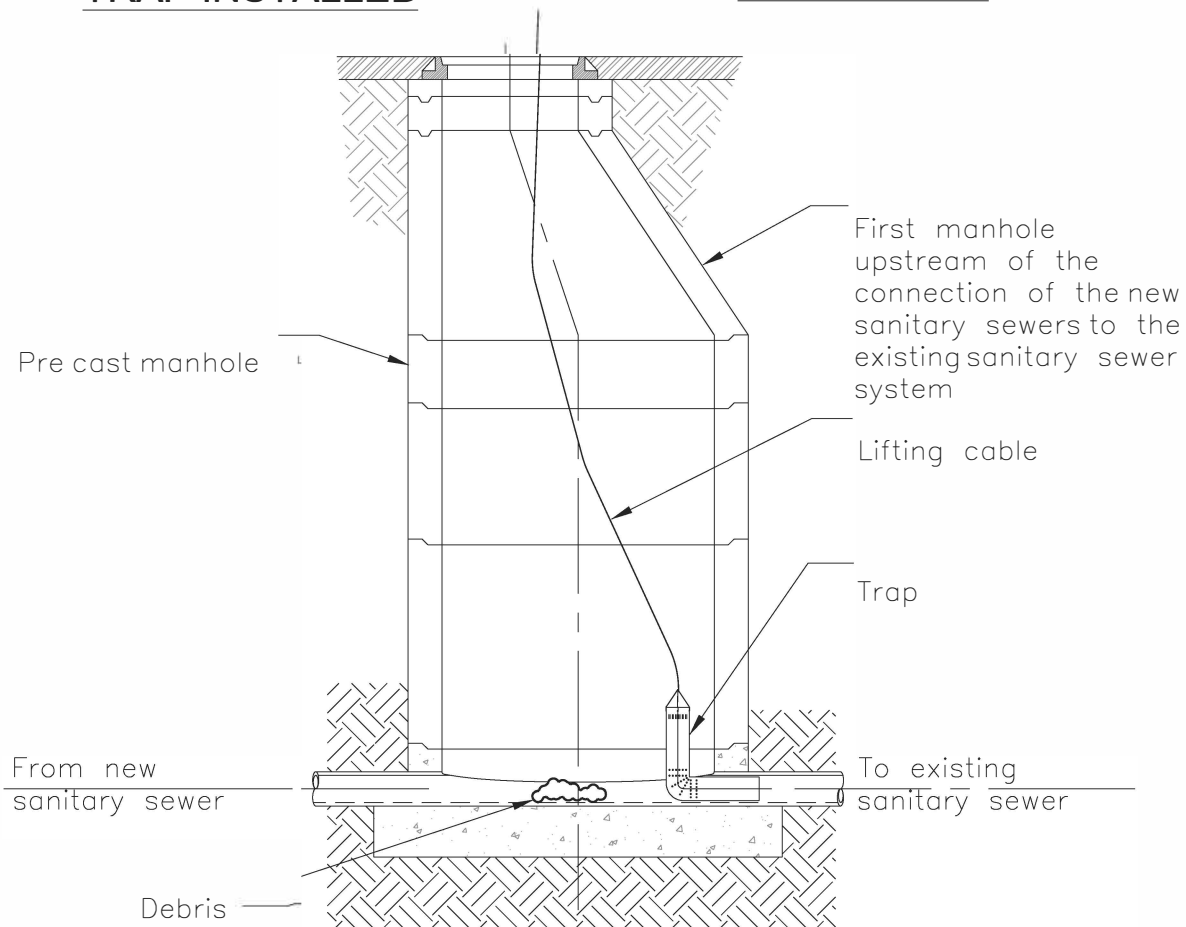




**CROSS SECTION OF
MH OUT PIPE WITH
TRAP INSTALLED**



**CUSTOM FABRICATED
METAL TRAP**



- NOTE:**
1. Provide debris traps when installing new SS to existing SS manhole.
 2. Debris to be cleaned prior to debris trap removal.
 3. Trap to remain in place until SS utilities have been accepted by owner.

DEBRIS TRAP FOR NEW CONSTRUCTION

ISSUED:

NUMBER: