

Notice: Per NRS 239B.030, this document does not contain personal information as defined in NRS 603A.040

Summary: Amends the Washoe County Code at Chapter 110 (Development Code) to change the required number of van accessible handicapped parking spaces from one per eight handicapped parking spaces to one per six handicapped parking spaces.

BILL NO. 1811

ORDINANCE NO. 1624

Title:

An Ordinance amending the Washoe County Code at Chapter 110 (Development Code) to change the number of van accessible handicapped parking spaces required in accordance with Washoe County Code Table 110.410.15.1 from one per eight handicapped parking spaces to one per six handicapped parking spaces for any parking facility serving the public; and, to address other matters necessarily connected therewith and pertaining thereto.

WHEREAS:

- A. The number of required van accessible handicapped parking spaces as prescribed in Washoe County Code Chapter 110 does not match the number of spaces as regulated in the 2012 International Building Code as adopted by Washoe County within Washoe County Code Chapter 100; and,
- B. Washoe County Code Section 110.818.60 provides a method to amend the Code by technical revision in order to conform with actions taken by another County agency, in this case the adoption of standards for the number of required van accessible handicapped parking spaces; and,
- C. The Director of the Planning and Building Division of the Washoe County Community Services Department initiated the proposed amendments on August 31, 2018 following the provisions of Washoe County Code Section 110.818.60(c)(1); and,
- D. The amendments and this Ordinance were drafted in concert with the District Attorney; and,

E. Following a first reading and publication as required by NRS 244.100(1), and after a duly noticed public hearing, this Board desires to adopt this Ordinance; and,

F. This Commission has determined that this ordinance is being adopted pursuant to requirements set forth in Chapter 278 of NRS, therefore it is not a "rule" as defined in NRS 237.060 requiring a business impact statement.

THE BOARD OF COUNTY COMMISSIONERS OF WASHOE COUNTY DOES HEREBY ORDAIN:

SECTION 1. Section 110.410.15 is hereby amended to read as follows:

Section 110.410.15 Special Parking Provisions.

- (a) Motorcycle and Bicycle Spaces. For every four motorcycle or six bicycle parking spaces provided, a credit of one parking space shall be given toward the requirements of this article, provided, however, that the credit for each shall not exceed 1/40 of the total number of automobile spaces required. If determined necessary by the County Engineer, bollards shall be installed to separate and protect motorcycle and bicycle spaces from automobile circulation. The minimum dimensions for motorcycle and bicycle spaces shall be as set forth in the following subsections:
 - (1) Motorcycle spaces shall be a minimum of seven feet in length and three feet four inches in width as illustrated in Figure 110.410.15.1.
 - (2) Bicycle spaces shall be a minimum of six feet in length and two feet six inches in width as illustrated in Figure 110.410.15.2.
- (b) Bicycle Storage. In commercial and industrial projects with 20 or more required parking spaces, a rack or other secure device for the purpose of storing and protecting bicycles from theft shall be installed. Such devices shall be provided with a minimum capacity of one bicycle per 20 required parking spaces and shall be located so as not to interfere with pedestrian or vehicular traffic.
- (c) Handicapped Parking. In any parking facility serving the public, parking for the handicapped shall be provided as set forth in this subsection.
 - (1) Handicapped parking spaces shall be provided in accordance with Table 110.410.15.1. One of every six required handicapped spaces shall be a van accessible space (a minimum of one van accessible space per parking area).
 - (2) Handicapped parking spaces shall be a minimum of eight feet in width and a minimum of 18 feet in length, as illustrated in Figure 110.410.15.3.
 - (3) Handicapped spaces shall be provided with an adjacent access aisle, as illustrated in Figure 110.410.15.3. Access aisles shall be a minimum of five feet

in width. Van access aisles shall be a minimum of eight feet in width. Access aisles shall be located on the passenger side of each space unless it is located between and is shared by two designated spaces.

- (4) Handicapped parking spaces and access aisles shall be level.
- (5) Handicapped spaces shall be located as near as possible to accessible building or site entrances and shall be located so as to provide convenient access to curb ramps.
- (6) Each reserved handicapped parking space shall be designated with a stall sign displaying the International Symbol of Accessibility, as illustrated in Figure 110.410.15.4. Each stall sign shall be at least 70 square inches in size. Spaces that are van accessible shall be designated as "Van Accessible."
- (7) Each reserved handicapped parking space shall meet one of the following stall markings requirements:
 - (i) Each handicapped parking space shall be painted solid blue with a white International Symbol of Accessibility; or
 - (ii) Each handicapped parking space shall be outlined in blue with a three foot square International Symbol of Accessibility painted in a contrasting color.
- (8) Each reserved handicapped parking space shall be marked with a sign warning drivers of the possibility of towing due to unauthorized use and providing information of recovering towed vehicles. Warning signs shall have minimum dimensions of 17 inches by 22 inches and shall be labeled with lettering of at least one inch in height.
- (9) A minimum of 98 vertical inches of clearance shall be provided for van accessible spaces and the entire route from parking area ingress/egress points to the parking space.
- (10) As illustrated in Figure 110.410.15.5, a minimum vehicle overhang allowance of 24 inches shall be provided between accessible routes and handicapped parking spaces. Said accessible routes shall, at all times, provide users with a minimum width of 36 inches of throughway.

Figure 110.410.15.1

MOTORCYCLE PARKING DIMENSIONS

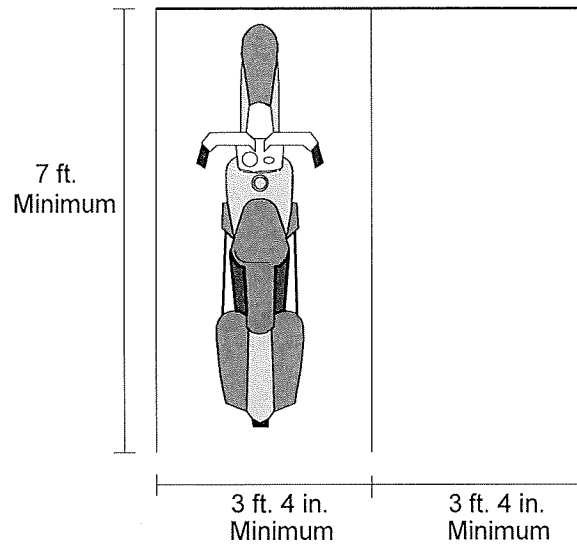

Source: Sedway Cooke Associates.

Figure 110.410.15.2

BICYCLE PARKING DIMENSIONS

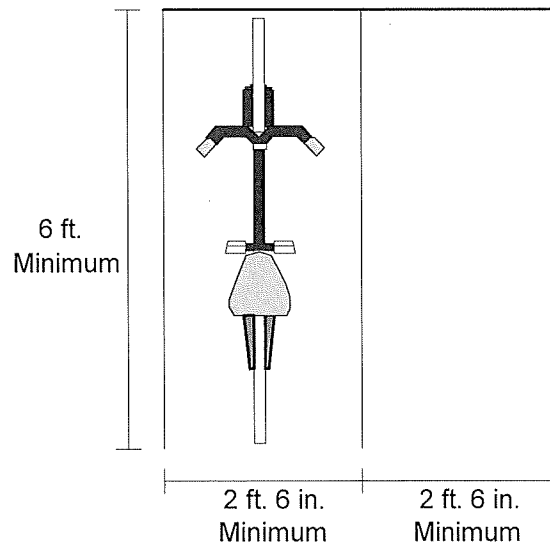

Source: Sedway Cooke Associates.

Table 110.410.15.1

HANDICAPPED ACCESSIBLE SPACES

Spaces in Lot	Required Number of Accessible Spaces
1 to 25	1
26 to 50	2
51 to 75	3
76 to 100	4
101 to 150	5
151 to 200	6
201 to 300	7
301 to 400	8
401 to 500	9
501 to 1,000	2 percent of Total
1,001 and over	20 plus 1 per 100 above 1,000

Source: Washoe County Department of Community Development.

Figure 110.410.15.3

HANDICAPPED PARKING DIMENSIONS

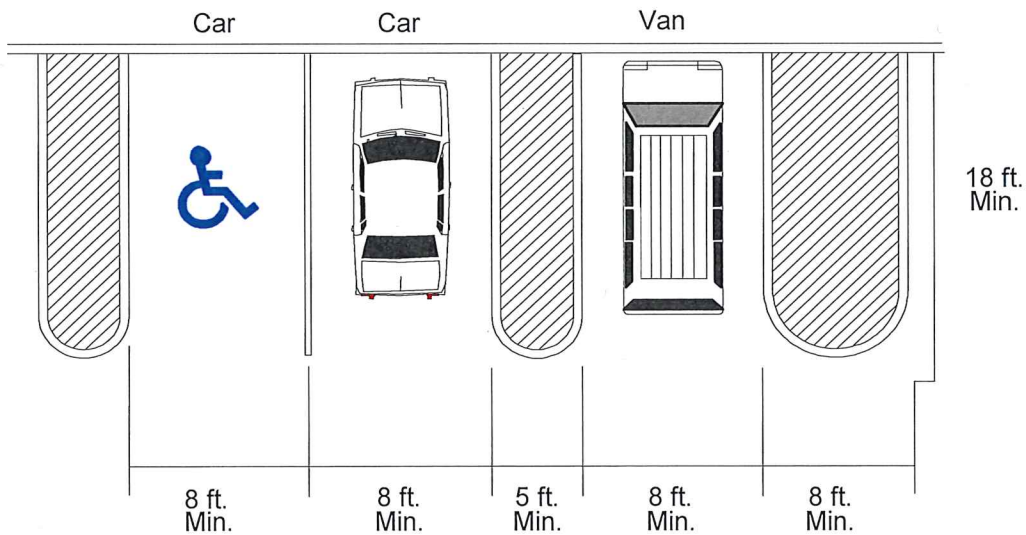

Source: Sedway Cooke Associates.

Figure 110.410.15.4

INTERNATIONAL SYMBOL OF ACCESSIBILITY



Proportions



Display
Conditions

Source: Sedway Cooke Associates.

Figure 110.410.15.5

ACCESSIBLE ROUTES

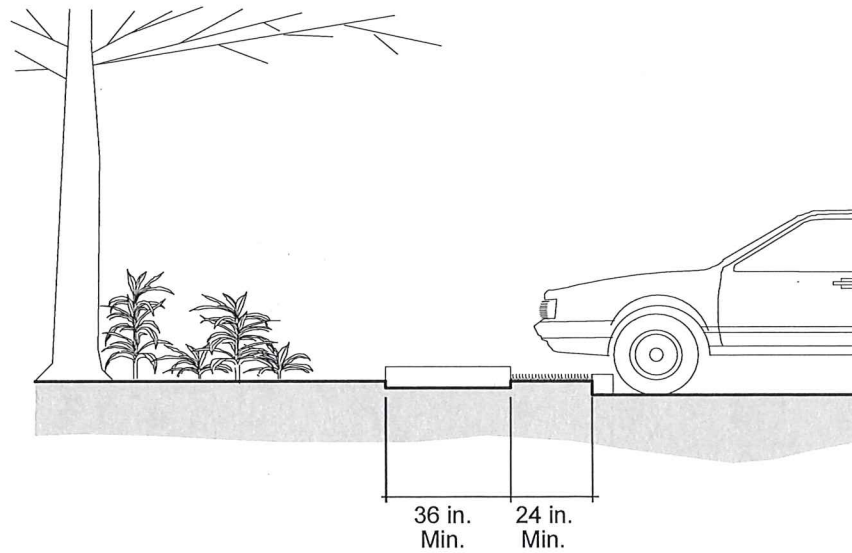

Source: Sedway Cooke Associates.

SECTION 2. General Terms.

1. All actions, proceedings, matters, and things heretofore taken, had and done by the County and its officers not inconsistent with the provisions of this Ordinance are ratified and approved.
2. The Chairman of the Board and officers of the County are authorized and directed to take all action necessary or appropriate to effectuate the provisions of this Ordinance. The District Attorney is authorized to make non-substantive edits and corrections to this Ordinance.
3. All ordinances, resolutions, bylaws and orders, or parts thereof, in conflict with the provisions of this Ordinance are hereby repealed to the extent only of such inconsistency. This repealer shall not be construed to revive any ordinance, resolution, bylaw or order, or part thereof, heretofore repealed.
4. Each term and provision of this Ordinance shall be valid and shall be enforced to the extent permitted by law. If any term or provision of this Ordinance or the application thereof shall be deemed by a court of competent jurisdiction to be in violation of law or public policy, then it shall be deemed modified, ipso facto, to bring it within the limits of validity or enforceability, but if it cannot be so modified, then the offending provision or term shall be excised from this Ordinance. In any event, the remainder of this Ordinance, or the application of such term or provision to circumstances other than those to which it is invalid or unenforceable, shall not be affected.

Passage and Effective Date

Proposed on OCTOBER (month) 9 (day), 2018.

Proposed by Commissioner HARTUNG.

Passed on OCTOBER (month) 23 (day), 2018.

Vote:

Ayes: KITTY JUNG, BOB LUCEY, JEANNE HERMAN

Nays:

Absent: MARSHA BERKBIGLER, VAUGHN HARTUNG



Marsha Berkbigler, Chair
Washoe County Commission

ATTEST:

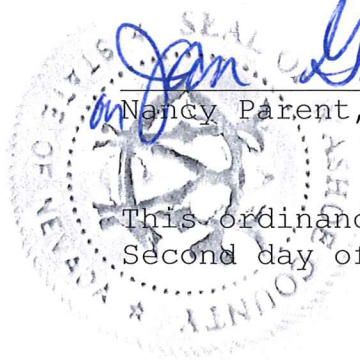
Jan Galassini, chief Deputy
Nancy Parent, County Clerk

This ordinance shall be in force and effect from and after the
Second day of the month of November of the year 2018.

**PROOF OF
PUBLICATION**

**STATE OF WISCONSIN SS.
COUNTY OF BROWN**

ACCOUNTS PAYABLE
WASHOE CO
1001 E 9TH ST

RENO NV 89512

Being first duly sworn, deposes and says: That as the legal clerk of the Reno Gazette-Journal, a daily newspaper of general circulation published in Reno, Washoe County, State of Nevada, that the notice referenced below has published in each regular and entire issue of said newspaper between the date: 10/26/2018 - 11/02/2018, for exact publication dates please see last line of Proof of Publication below.

10/26/18, 11/02/18



Legal Clerk

Subscribed and sworn before me this
2nd of November 2018.



NOTARY PUBLIC RESIDING
AT STATE OF WISCONSIN
COUNTY OF BROWN

Notary Expires: 9-19-21

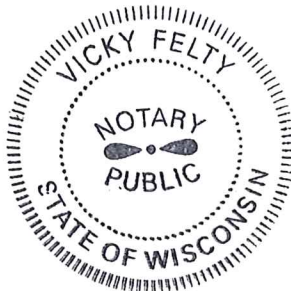

WCCOMP NOV 6'18 9:33

Ad#:0003221877
P O : Ordinance 1624
of Affidavits : 0 00

**NOTICE OF ADOPTION
WASHOE COUNTY ORDINANCE NO. 1624
BILL NO. 1811**

NOTICE IS HEREBY GIVEN that typewritten copies of the above-numbered and entitled ordinance are available for inspection by the interested parties at the office of the County Clerk of Washoe County, Nevada, at her office in the Washoe County Complex, 1001 E. Ninth Street, Building A, Reno, Washoe County, Nevada; and that the ordinance was proposed on October 9, 28, 2018 by Commissioner Hartung and was passed and adopted without amendment at a regular meeting held on October 23, 2018 by the following vote of the Board of County Commissioners:

AN ORDINANCE AMENDING THE WASHOE COUNTY CODE AT CHAPTER 110 (DEVELOPMENT CODE) TO CHANGE THE NUMBER OF VAN ACCESSIBLE HANDICAPPED PARKING SPACES REQUIRED IN ACCORDANCE WITH WASHOE COUNTY CODE TABLE 110.410.15.1 FROM ONE PER EIGHT HANDICAPPED PARKING SPACES TO ONE PER SIX HANDICAPPED PARKING SPACES FOR ANY PARKING FACILITY SERVING THE PUBLIC; AND, TO ADDRESS OTHER MATTERS NECESSARILY CONNECTED THEREWITH AND PERTAINING THERETO. (BILL NO 1811)

Those Voting Aye: Kitty Jung, Bob Lucey, and Jeanne Herman.

Those Voting No: None.

Those Absent: Marsha Berkbigler and Vaughn Hartung

This Ordinance shall be in full force and effect from and after November 2, 2018.

IN WITNESS WHEREOF, the Board of County Commissioners of Washoe County, Nevada, has caused this Ordinance to be published by title only.

DATED: October 23, 2018.

Nancy Parent, Washoe County Clerk and
Clerk of the Board of County Commissioners

No 3221877

Oct. 26; Nov. 2, 2018



PART OF THE USA TODAY NETWORK

The Mason Valley News

"The Only Newspaper in the World that Gives a Damn About Yerington"

Order Confirmation for Ad #: 0003221877

Customer: WASHOE CO
Address: 1001 E 9TH ST
 RENO NV 89512 USA
Acct. #: REN-349008
Phone: 7753282569

 WASHOE CO
Ordered By: Derek Sonderfan

OrderStart Date: 10/26/2018 Order End Date: 11/02/2018

<u>Tear Sheets</u>	<u>Affidavits</u>	<u>Blind Box</u>	<u>Promo Type</u>	<u>Materials</u>	<u>Special Pricing</u>	<u>Size</u>
0	1					2 X 29.00

<u>Net Amount</u>	<u>Tax Amount</u>	<u>Total Amount</u>	<u>Payment Method</u>	<u>Payment Amount</u>	<u>Amount Due</u>
\$411.00	\$0.00	\$411.00	Invoice	\$0.00	\$411.00

Ad Order Notes:

Sales Rep: kthor Order Taker: kthor Order Created: 10/24/2018

Product	# Ins	Start Date	End Date
REN-Gazette Journal	2	10/26/2018	11/02/2018
10-26-18, 11-02-18, REN-rgj.com	2	10/26/2018	11/02/2018
10-26-18, 11-02-18,			

* ALL TRANSACTIONS CONSIDERED PAID IN FULL UPON CLEARANCE OF FINANCIAL INSTITUTION

Text of Ad: 10/24/2018

NOTICE OF ADOPTION
 WASHOE COUNTY ORDINANCE NO. 1624
 BILL NO. 1811

NOTICE IS HEREBY GIVEN that typewritten copies of the above-numbered and entitled ordinance are available for inspection by the interested parties at the office of the County Clerk of Washoe County, Nevada, at her office in the Washoe County Complex, 1001 E. Ninth Street, Building A, Reno, Washoe County, Nevada; and that the ordinance was proposed on October 9, 28, 2018 by Commissioner Hartung and was passed and adopted without amendment at a regular meeting held on October 23, 2018 by the following vote of the Board of County Commissioners:

AN ORDINANCE AMENDING THE WASHOE COUNTY CODE AT CHAPTER 110 (DEVELOPMENT CODE) TO CHANGE THE NUMBER OF VAN ACCESSIBLE HANDICAPPED PARKING SPACES REQUIRED IN ACCORDANCE WITH WASHOE COUNTY CODE TABLE 110.410.15.1 FROM ONE PER EIGHT HANDICAPPED PARKING SPACES TO ONE PER SIX HANDICAPPED PARKING SPACES FOR ANY PARKING FACILITY SERVING THE PUBLIC; AND, TO ADDRESS OTHER MATTERS NECESSARILY CONNECTED THEREWITH AND PERTAINING THERETO. (BILL NO 1811)

Those Voting Aye: Kitty Jung, Bob Lucey, and Jeanne Herman.
 Those Voting No: None.
 Those Absent: Marsha Berkbigler and Vaughn Hartung

This Ordinance shall be in full force and effect from and after November 2, 2018.
 IN WITNESS WHEREOF, the Board of County Commissioners of Washoe County, Nevada, has caused this Ordinance to be published by title only.

DATED: October 23, 2018.

Nancy Parent, Washoe County Clerk and
 Clerk of the Board of County Commissioners

No 3221877 Oct. 26; Nov. 2, 2018

1624